

## GOVERNMENT IN WANGGULAM



VERHANDELINGEN  
VAN HET KONINKLIJK INSTITUUT  
VOOR TAAL-, LAND- EN VOLKENKUNDE

57

GOVERNMENT  
IN  
WANGGULAM

A. PLOEG



THE HAGUE - MARTINUS NIJHOFF - 1969



## PREFACE

During my stay among them the Wanggulam were deeply upset by the sudden changes brought about since the arrival of the Europeans only a few years earlier. In this book I discuss the expectation nourished by the Wanggulam and provoked by these changes. Without the help of this discussion I cannot clarify the nature of my relation to the people and consequently I have to postpone the main acknowledgement I wish to make.

This book is based on a thesis presented for the degree of Doctor of Philosophy in the Australian National University. I would like to thank the University for granting me a scholarship and the staff and students of its Department of Anthropology and Sociology for their comments and criticisms. Before all I have to thank Professor J. A. Barnes, Dr M. Reay and Dr P. Brown, who supervised my work in its different stages. I feel particularly indebted to Professor Barnes since he supervised the final writing up of the material and later gave me the opportunity to prepare the thesis for publication.

I would like to thank Professors J. Pouwer and L. A. Fallers and Dr H. I. Hogbin who acted as examiners of my Ph. D. thesis. Although during the revision I tried to meet their criticisms as well as I could, I realise I have not satisfied all their wishes.

I appreciate the support of Mrs D. A. O'Brien, then a graduate student in anthropology at Yale University, in collaboration with whom I wrote a paper 'Acculturation Movements among the Western Dani', published in the *American Anthropologist*, Vol. 66, ii, pp. 281-92. The better part of chapter 4, section III is based on this paper.

I am very grateful to the members of the Bureau of Native Affairs of the Administration of Netherlands New Guinea, the administrative personnel in Mbogondini and the missionaries of the Unevangelised Fields Mission for the support they gave me during my field trips.

I am further indebted to Professor Barnes, Professor S. A. Wurm, Miss H. Leach and Miss S. Baume, as well as a great many other people, who corrected my use of English.

Finally I would like to thank Mrs Y. McMahon for typing the

second half of the manuscript and Mrs M. L. Ploeg for typing the first half and for preparing the maps and figures.

The book is divided into two parts. The first part, consisting of the introduction and first four chapters, contains a brief description of some main features of the Wanggulam social system and provides the background information to the analysis of Wanggulam government which is presented in the second part consisting of the last five chapters. Some topics mentioned in the first part are very briefly discussed, since I intend to publish more extensive discussions in separate papers later. By contrast, chapter 9, the last chapter of the book, is a rather extensive discussion of theoretical developments in political anthropology since 1940. This discussion was appropriate as a part of a Ph. D. thesis, but seen its length I consider it less appropriate as a part of this book. However, my efforts to reduce the size of the last chapter were largely unsuccessful. There are two reasons for this. Firstly, I wanted to preserve the structure of chapter 9 and found that this necessitated retaining most of its content. Secondly, I based my analysis of Wanggulam government to a large extent on the writings of M. G. Smith. Since I have become more critical of his views since I wrote and presented my Ph. D. thesis in 1965, I had to extend my discussion of his writings to show where I disagreed with him.

## TABLE OF CONTENTS

PREFACE . . . . .	V
LIST OF FIGURES . . . . .	VIII
LIST OF TABLES . . . . .	VIII
LIST OF CASES . . . . .	IX
SPELLING OF WORDS IN THE VERNACULAR . . . . .	X
SYMBOLS INDICATING KIN RELATIVES AND RELATIONSHIPS . . . . .	XI
INTRODUCTION . . . . .	1
CHAPTER	
1 Material culture and mode of livelihood . . . . .	8
2 Kin and territorial groups . . . . .	12
3 Maintenance of social relationships . . . . .	24
4 Supernatural powers . . . . .	46
5 Conceptual framework for the analysis of Wanggulam government; autonomy and reciprocity . . . . .	66
6 Competitive leadership . . . . .	75
7 Partnership . . . . .	112
8 Conflicts and settlements . . . . .	133
9 Conclusion . . . . .	168
BIBLIOGRAPHY . . . . .	196
INDEX . . . . .	201
APPENDIX . . . . .	208
MAPS . . . . .	211
I Irian Barat . . . . .	212
II Western Dani area . . . . .	213
III Wanggulam territory (1) . . . . .	214
V Wanggulam territory (2) . . . . .	215
VI Feasting ground for the Penggu pandanus feast . . . . .	216
IV Aerial photograph of Wanggulam and surroundings	

## LIST OF FIGURES

Figure	1	Plan of fenced in hamlet . . . . .	9
	2	Sequence of prestation during a Wanggulam wedding	32
	3	Flow of payments assembled and distributed during the wedding of a mother and her daughter . . . .	33
	4	Perenatmendek's closest relatives . . . . .	55
	5	Closest relatives of Agalai . . . . .	57
	6	Inhabitants of Mbobigi's and Ngabengga's hamlets in December 1961 . . . . .	82
	7	Jiwaru's closest relatives . . . . .	96
	8	Skeletal genealogy of Karoba II . . . . .	126
	9	Mbabuarek's sub-section . . . . .	142
	10	Kin relationships Ngwembanik — Anarak — Amianongga — Mbilumu . . . . .	149
	11	Partial genealogies of Karoba I and Karoba II . . . .	155
	12	Evans-Pritchard's diagrammatic representation of the structure of a Nuer tribe . . . . .	171

## LIST OF TABLES

Table	1	Composition of Wanggulam parish . . . . .	14
	2	Composition of Wanggulam parish in detail . . . .	15
	3	Residence pattern of full brothers . . . . .	20
	4	Contributions to <i>uak</i> (bride's father's prestation) . .	28
	5	Contributions to bride price ( <i>kwe onngo</i> , groom's father's prestation) . . . . .	29
	6	Comparison of the size of the <i>uak</i> assembled for a girl with the size of the bride price assembled during her wedding . . . . .	31
	7	Wanggulam and foreign contributors to <i>uak</i> . . . .	40
	8	Wanggulam and foreign contributors to bride price	41
	9	Wanggulam and foreign recipients of <i>uak</i> . . . .	42
	10	Wanggulam and foreign recipients of bride price . . .	43
	11	<i>Uak</i> for Waage and Mbukmba . . . . .	102
	12	Contributors to the <i>jowam</i> for Ambenggonok . . . .	145
	13	Recipients of <i>jowam</i> for Ambenggonok . . . . .	146

## LIST OF CASES

Case	1	Tilubagatlak kills Ngerenggaligwe's son . . . . .	54
	2	The position of Wandin . . . . .	78
	3	Mbobigi, Ikwenggorok (his son) and Erimawe (his sister's son) . . . . .	83
	4	Oil pandanus feast organised by the Wanggulam Penggu . . . . .	86
	5	Wandin versus Mbabuarek . . . . .	91
	6	Wogogi's dog . . . . .	92
	7	Mbilumu tries to abduct Mbukmba . . . . .	92
	8	Wanggulam versus Ngigamuli . . . . .	95
	9	Jiwaru . . . . .	95
	10	Ownership of earth ovens during the Penggu pandanus feast . . . . .	122
	11	Luki versus Ambenggonok . . . . .	125
	12	Preliminaries to fights between Wanggulam and Tukobak . . . . .	133
	13	Liokwe recovers his pig . . . . .	136
	14	Opening of Agawak . . . . .	139
	15	Mbabuarek moves south of the Kurip . . . . .	141
	16	<i>Jowam</i> taken by Luki after Ambenggonok's killing . . . . .	144
	17	Ngwembanik versus Amianongga versus Mbilumu . . . . .	149
	18	Jilobo's death . . . . .	150
	19	Enggawarek's death . . . . .	154
	20	Ngwembanik kills Enggangkok . . . . .	160
	21	Kondaga tries to marry his daughter to Lembiagop . . . . .	161
	22	Ngobak and Mbunarek try to kill Jikwanak . . . . .	163

## SPELLING OF WORDS IN THE VERNACULAR

There is not yet an agreed spelling of Dani, or Ndani, the language spoken in Wanggulam and the surrounding areas. There are differences in the spelling used by various writers, and the spelling I use is different again. I do not claim linguistic correctness, but have tried to follow Dani pronunciation closely without bothering the English reader.

Vowels can be long or short; their quality and that of diphtongs are approximately as follows:

'a'	as in Northern English:	cat (Dutch: af)
'e'	as in English:	bell
'i'	as in English:	reed
'o'	as in Scottish:	go (Dutch: bok)
'u'	as in English:	book
'au'	as in English:	cow
'ei'	as in Australian English:	late (Dutch: bijl)

Consonants should be pronounced as in English, but watch:

'g'	as in: go,	never as in: gin
'ngg'	as in:	finger

It would have been consistent if I had used the term 'Ndani' instead of 'Dani', but I decided to use the latter term to conform with the usage of other writers, for example Bromley (1960 and 1962) and Peters (1965). Further, at the time of my field work, the term 'Bokondini' was used to refer to the mission and government stations located in the areas where I worked. Since I presumed that after the Indonesian government had taken over the administration of Irian Barat, this name might have been changed into 'Mbogondini', I decided to use the latter term. However, after the manuscript had gone to the press, I noticed in the United Nations' publication 'A Design for Development in West Irian' (New York, 1968), that the term Bokondini seems to be still in use.

## SYMBOLS INDICATING KIN RELATIVES AND RELATIONSHIPS

To indicate kin relatives and relationships I use the notational system proposed by Colson and Gluckman (1951; p. xx) and recently recommended by Barnes (1967; pp. 122-123). This system employs the following symbols:

W wife	Z sister	K classificatory
H husband	B brother	+ elder
E spouse	G sibling	— younger
M mother	D daughter	□ marriage tie
F father	S son	□ sibling tie
P parent	C child	— parent-child tie

Females are shown by the symbol ○, males by the symbol △, deceased persons by the symbols ● and ▲. The symbols □ and □ are used interchangeably. They indicate the relationship between classificatory siblings, in other words the relationship between members of the same *anembeno* (see p. 13) who belong to the same generation.



## INTRODUCTION

This book is concerned with a group of about 500 people living in the Central Highlands of what is now Irian Barat. To themselves and their neighbours these people are known as the Wanggulam. The Wanggulam form one out of six political communities living in a river valley system which they call Mbogoga, after its main river, the Mbogo. Mbogoga is situated in the upper catchment area of the Hablifoeri (see maps I and II. The maps are inserted at the end of the book). The main feature of its topography is a large plateau more than two miles long, called Mbogondini. It is more than two miles long and is raised from 450 to 600 feet above steep valleys through which the mountain rivers flow swiftly. The altitude of the plateau is about 4000 feet above sea level. Mbogoga is surrounded by rugged mountain country, partly uninhabited.

The climate is agreeable with a moderate temperature all the year round. Rainfall is heavy. At the plateau the annual fall is about 130 inches, but this amount may not be representative as it is based upon only three years of observation; moreover rainfall varies in the different parts of the valley. Most of the rain falls in heavy showers in the late afternoon, evening and night. It continues during the drier season in the middle of the year and it is unusual to have two successive days without rain.

The inhabitants of Mbogoga form part of the larger grouping known as the Ndani, or Dani. This name is given by groups living in more westerly areas of the highlands to their eastern neighbours (Le Roux; 1950, pp. 665 ff.). The Dutch administration of Irian Barat and the missions have used the name to indicate a group of people speaking a number of related dialects and languages. The total number of speakers has been estimated to be as many as 200,000 (Bromley; 1960, p. 235). Dani languages are spoken over a large area containing the upper catchment area of the Hablifoeri, the Swart, the upper Nogolo and their tributaries (see map II). The Mbogoga Dani have many contacts with the Swart area and almost none with the Baliem area and it would seem that the watershed dividing them in the south from the Baliem people constitutes a clearer linguistic and cultural boundary

than that which divides them from the Swart people in the west. The latter are the closest western neighbours of the Dani at Mbogoga. Their immediate eastern and southern neighbours, the people living between Mbogoga and the Baliem-Hablifoeri divide, seem to resemble them a great deal. The valleys to the north are presently uninhabited. Farther afield, the pattern of population distribution is not clear.

No census has been taken in Mbogoga, but I would estimate the population at 3,000 people. They are divided into six named parishes (Hogbin and Wedgwood; 1953, p. 253). I lived about 18 months in Mbogoga, from May 1960 till March 1961, and from December 1961 till August 1962, spending most of this time among the Wanggulam, one of the six communities. Wanggulam territory is situated on both sides of the Kurip River (see maps III and IV). Most Wanggulam settlements are on the tract of land bounded by Kurip, Luaga and Nganu, which is the core part of the territory. The name Wanggulam derives from that of a creek, Wangguli, flowing through this area. When war seemed likely or was actually going on, the Wanggulam often took refuge in the core area. The last retreat took place in 1960 and since then the Wanggulam have expanded, building a number of new settlements outside the core area (see map III, A). It is not known how far the expansion will go so that part of the parish boundary is uncertain.

These moves followed extensive migrations which had occurred in Mbogoga during the two decades before 1960. In the course of my field work I collected data on fights which had taken place between the Mbogoga parishes during the period 1930-1960. These data show that the localities of the parishes had fluctuated a great deal. It appeared also that at least some of them disposed of more than one territory. The Wanggulam said this was the usual thing and that people went from one territory to the other on account of fighting; when a community suffered heavy losses or when its members were afraid it might suffer losses, they moved to its other territory. Another factor was possibly the availability of cultivable land. During my stay the Wanggulam complained about the yields of their swiddens and they said they intended to go to Abena, their other territory, because its soil was much more fertile. This territory is situated in a valley north of Mbogoga, and was uninhabited during my stay (see map IV).

About 1942 the Wanggulam had fled there to escape from a war in which the Tukobak, their southern neighbours, living on and near the large plateau, had killed at least ten Wanggulam. After they had lived

in Abena for two or three years, the Tukobak had attacked again, so that the Wanggulam had to flee once more. Many went to Panaga, in the Swart Valley area, where they stayed another three to five years. Others took refuge in other parts of the Highlands.

In addition to the Wanggulam their easterly neighbours living on the north bank of the Mbogo, and their southwesterly neighbours living on the upper reaches of the Kurip river, also fled Mbogoga. During the absence of these three parishes, the Tukobak were in their turn defeated by people living east of Mbogoga and they fled westwards to the vacated upper part of the Kurip valley. Little by little they returned eastwards to their former territory near the large plateau, making swiddens in areas formerly cultivated by the Wanggulam and by other Mbogoga groups. Before the Tukobak had returned to the large plateau, the Wanggulam returned in small groups to Mbogoga, first settling down in the upper reaches of the Kurip and afterwards returning to their former territory near the Wangguli. The expansion which took place during 1960-1962 occurred in areas which the Wanggulam had cultivated before 1942, but which in the period between 1942 and 1960 had been cultivated by the Tukobak. During my stay the Tukobak were still moving eastwards. In 1960 they started to leave the areas on and near the large plateau because they disliked living close to the government post and moved to their second territory.

In the course of my field work the Wanggulam still often referred to the fights with the Tukobak and the time spent away from Mbogoga. In other parts of the book I present more data on these subjects.

The Wanggulam provided me with most of my information. There are no indications that there exist marked differences between Wanggulam and the other Mbogoga Dani, but I cannot confirm that the analysis of Wanggulam society would apply without modification to the other communities. My concentration of interest on the Wanggulam is due to a number of factors; to explain these it is necessary to describe the relations between the Mbogoga Dani and the Europeans in their vicinity.

Regular contacts with Europeans started in 1956 when missionaries of the Unevangelised Fields Mission established a station and an airstrip on the plateau at Mbogoga. Three years later the then Dutch administration set up another station also on the plateau. Missionaries, government officials and the natives themselves refer to the site of these stations as Mbogondini, which was originally the name of a tract of land on the plateau.

The attitude of the Mbogoga Dani towards their European neighbours was not unfavourable. The new arrivals had an abundance of highly valued objects (such as cowrie shells, bush knives, and steel axes), and the Dani were eager to work on the projects undertaken by the Dutch administration and the mission in order to acquire some of these goods. When I arrived in May 1960 the flow of Western goods had not been large and only a few men owned steel axes or bush knives, but by March of the following year nearly every man owned one or the other, or both. Soon all men owned them and Mbogoga started to become an export centre for these objects, which were bartered to people of other valleys for valued products of their own culture. The government employed many more people than the mission, and its station was the only government post in the western Dani area. Hence the Mbogoga Dani were in an exceptionally favourable position. The introduction of Western goods led to other important changes in the traditional economy. The Wanggulam assert that the introduction of the steel axe enabled them to clear larger tracts of land and also put them into a better position to open tracts covered with jungle. Mr. S. Smit, the local Government Medical Officer, supported this assertion and said that, in the few years since the establishment of the Mission Station, he had observed a great improvement in the general physical appearance of the people living in Mbogoga, which he attributed to the increased food supply.<sup>1</sup>

The missionaries had little success in their attempts to put an end to the frequent fighting between the political communities of Mbogoga, but the government managed to end warfare within a year after its arrival. It did not need a great display of force and there were no casualties. The ban of fighting was the only restriction the government imposed on the activities of the Dani. There were no regular patrols through Mbogoga itself. The natives were not required to work for the government, and people who did not work regularly at Mbogondini had only occasional contact with government officials.

The efforts of the missionaries to spread the Christian faith did not

---

<sup>1</sup> If the assertion of the Wanggulam be correct, their response contrasts with that of the Siane (Salisbury; 1962, p. 109), who did not use the more effective steel tools to increase the size of their gardens. This may be connected with another difference between Siane and Mbogoga Dani; Salisbury shows that the diet of the Siane was and is "more than sufficient" (1962, p. 81), while it seems that before the arrival of the Europeans, the diet of the Wanggulam was insufficient, so that it is understandable that they felt the need to enlarge their gardens, while the Siane did not.

meet with much response from the Dani till the first months of 1960, when a missionary visited Mbogondini from Ilaga (the western boundary of the Dani), accompanied by a number of native evangelists. Their crusading had a sharp impact upon the Mbogoga Dani. The religious movement that followed is described in O'Brien and Ploeg (1964). The fortunes of this movement, which flourished throughout the period of my association with the Wanggulam, profoundly influenced my relations with them. They saw me as a European, and the conspicuous luxury of my house and surroundings, compared with their own, helped to maintain this distinction. They appreciated my stay more because I provided them with Western goods — just as the other Europeans did — than because I invited them into my house, ate and smoked with them, and tried to cooperate in their activities. They saw me not as an observer, but as a participant, a man who played a role in the developments since 1956. The Dani feared that the Europeans, including myself, would leave if they did not accept the Christian faith, and they knew that this departure would cut off the possibility of their attaining the things they valued in the European way of life. Consequently they were eager to show that they followed a 'Christian' line of behaviour. Most people were reluctant to tell me about their feelings regarding conversion. They expected and evidently wanted me to promote their welfare, and they interpreted my stay among them as another opportunity to show the sincerity of their conversion. Although I denied this and people said they accepted the sincerity of my denials, I wonder whether the Wanggulam were really prepared to believe that my record of their way of life was intended to inform my readers, rather than to allow them to pass judgment. My efforts to explain the reasons for my stay were unsuccessful. The reasons I advanced were not easily believed, for they did not suit the needs of the Wanggulam. I gained the impression that my investigations provided the people with confirmation of the illusions currently being nurtured by the religious movement. I had to be very careful not to be put into the position of a moralist telling the Wanggulam how they should and should not behave. People often asked me to tell them about the mission teachings, and they seemed not to believe me when I said that I was not a Christian. It was difficult to get information on central topics like the views of the Wanggulam about their pre-contact culture, because they were too willing to say simply that it was "bad" while their new way of life was "good". Some of the information I obtained was given in the form of confessions. Questions about traditional rites

and about wars and fights were often regarded as invitations to tell about sins of the past. Failure to confess, the Wanggulam felt, might have serious consequences. Sometimes after a number of their close kin had died people came to tell me about their ancestors (who were considered as 'bad', since their spirits were believed to have instigated their progeny to warfare) in order to prevent further bereavements. In such cases I felt I could not accept this information and, although I tried to explain why I did not accept it, people may have felt cheated. A few men explicitly told me that the Wanggulam were not convinced that the high hopes provoked by the presence of the white man would be soon fulfilled. That these statements were correct was indicated by further data (see p. 63). I disliked the position I was in. Simply to acknowledge the support and friendship the Wanggulam provided me with, would ignore the disappointment the people probably felt about the meagre advantages (a number of steel axes, a few clothes, salt and cowrie shells) which resulted from my prolonged stay among them.

Other difficulties hampered the collection of material. Wanggulam are not willing to tell each other the truth about their affairs, and they have developed an expert ability to lie with a very friendly face and a very trustworthy manner. The habit of lying led often to exasperating situations: it was unwise to rely upon any promise; it was difficult to obtain precise information about coming events; and it was necessary to check almost all information. People did not expect me to tell them the truth either, so they were easily inclined to discard as apocryphal any explanation I gave for my inquiries. People were rather laconic about the frequent lying. They did not openly condemn lying, and they did not get angry when they discovered that others had lied to them. It seems to me that this attitude is characteristic of Wanggulam society and possibly of the whole region. As it took a long time before I could obtain reliable data from the Wanggulam it seemed likely that short contacts with other groups would yield little. This was another reason for limiting my investigations to Wanggulam.

The second difficulty was my imperfect command of the Dani language. Before arriving in Mbogoga I knew about the language only from an elementary grammar,<sup>2</sup> and I had to build up a vocabulary and extend my knowledge of the grammar while in the field. The Wanggulam and I did not have a *lingua franca* as an aid to communication and as a means whereby I might study their dialect. During the last

---

<sup>2</sup> Mr. F. C. Horne, missionary of the Unevangelised Fields Mission, lent me this extremely useful grammar.

part of the field work I could understand most of the answers to my questions, and I had a limited understanding of conversations between Wanggulam, but sometimes I had difficulty in framing a question, and I never reached the proficiency in the language I desired.

In the following chapters I will describe the main features of the traditional culture of the Wanggulam. During my stay among them the people were in the process of abandoning many of these features and the fact that some were being retained while others were being abandoned makes for difficulties in presentation in this book. Initially I intended to refer in the present tense to those cultural features still retained during the first part of my stay, and in the past tense to features being abandoned at that time. This procedure proved to be impracticable since it led to a very tangled and confusing use of tenses. In chapter 4 for example, when discussing supernatural beings and powers, I had to use the past tense to describe the discontinued ceremonies and rites, but the present tense to describe the spirits and their attributes, since people still believed in the existence of the spirits. I have therefore decided to use the present tense throughout except when referring to specific events which took place in the course of my field trips. By using this method of presentation I have avoided some tangled use of tenses, but I have not completely avoided inconsistencies. In several instances I mention that fights and battles were a thing of the past during my stay, only to refer to them in the next paragraph in the present tense as if they were still in existence. To prevent confusion therefore I indicate several times in the course of the argument which of the features under discussion were still retained and which were being abandoned.

## CHAPTER 1

### MATERIAL CULTURE AND MODE OF LIVELIHOOD

Mbogoga material culture is simple, but most of the materials — with the notable exception of the stone adzes and axes — are very efficient. Many tools are not durable, but are made for the occasion and abandoned afterwards. Manufacturing techniques are on the whole simple. Spinning is unknown: ropes and strings are made by twisting bark fibres. Weaving is known, but rarely practised. A number of fairly elaborate methods of plaiting, netting, and knitting are known and used in the manufacturing of bags, bands, and armour. Pottery and basketry are unknown. Decorating devices are simple, and moreover are not used extensively. Carving occurs only on arrows used for fighting. The motifs are not very elaborate. Bags, and other plaited and knitted articles, are decorated with orchid and other fibres (see Le Roux; 1948, p. 389) with a very limited colour variation.

In this overall simplicity Mbogoga material culture resembles the cultures of the highlands of East New Guinea, but — especially with regard to ceremonial dresses and objects — it is less colourful and less elaborate (see Read; 1954, p. 9).

The main garment for men is a penis gourd. Most men wore until 1962 one or more headbags, covered with a mixture of soot, resins and pigfat. Most wore also one or other form of 'neckwear', either simply a few strips of flattened bark, or parts of insect nests, or bands set with shells, or strips of bailer shell. By 1962, under the influence of the religious movement, men tended to abandon both bags and neckwear. The main garment for women is a skirt. There are two types; one is made of a long cord to which are tied freehanging cords up to 15 inches long. The other type, used by married women only, consists of long flat plaited bands, adorned with orchid and other fibres. The bands are wound horizontally around the hips. The first part of the marriage ceremonies consists of dressing a girl in a skirt of this type.

Mbogoga Dani live in small hamlets. There are two types of houses with only minor differences in construction. I will refer to these types

as men's houses and women's houses, mainly because the adult men spend the night in the one type and the women and children in the other. Both types are circular, with a conical roof covered with thatched grass. The wall is made of a double row of vertical, adzed planks. The diameter of a house is about 14 feet.

The houses of a hamlet are arranged according to a plan: there is one men's house in a hamlet, situated at the apex of a long yard. The women's houses are on the long sides of the yard facing each other. The number of women's houses varies from one to six. About half of the Wanggulam hamlets were fenced in at the time of my field work.

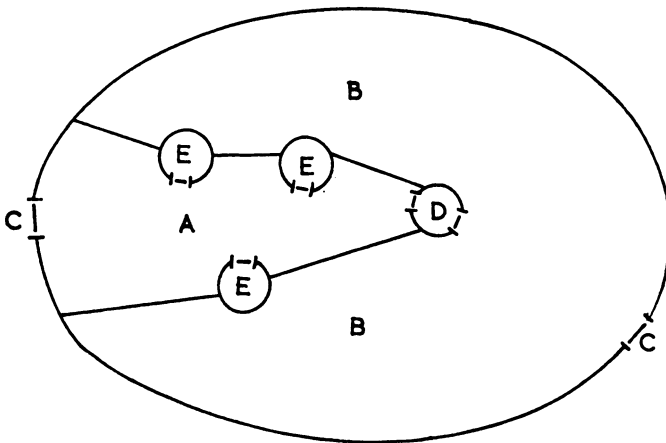

FIGURE 1: PLAN OF A FENCED IN HAMLET

The yard (see figure 1, A) with the houses is surrounded by a garden in the form of a horseshoe (B), so that the groundplan of the hamlet is roughly elliptical. The whole is enclosed by a heavy fence, about seven feet high. The yard is closed off from the garden by a lower fence with a few crossings. There are two gates in the outer fence (C), in most cases aligned with the two doors of the men's house (D). Women's houses (E) have only one door leading towards the yard. The size of a yard of a hamlet with three women's houses is about 40 by 15 yards, and the length and width of the hamlet itself are about 60 and 40 yards respectively.

Hamlets are often quite close, within 300 yards from each other. Due to the ruggedness of the country and the rich vegetation one rarely sees more than two other hamlets from any one and often none at all.

Traditionally the objects most highly valued by the Wanggulam were long, knitted bands set with cowrie shells, and *jao*, blue-greenish oblong stones, approximately cylindrical or triangular in shape. These stones occur also in other parts of the Highlands (see Bromley; 1960, p. 238, and Wirz; 1924, p. 64). Their functions seem to differ in the different areas. In Mbogoga they are, together with the bands with cowrie shells, odd cowrie shells, and pigs, items in wedding, cremation and compensation payments. The cylindrical stones are male, the triangular ones female. The male stones symbolise the penis, the female stones the several parts of the female body. People enjoy just seeing, rubbing, and manipulating the stones. It seems to me that their value is clearly connected with their being sexual symbols. There are more female stones than male ones, and the latter tend to have a higher value than the former.

Until the middle of 1961 cowrie shells were still so highly valued that one shell was accepted as one day's wage, notwithstanding the large quantities mission and government had already handed out. Later on the wage became two shells. The knitted bands on which they are set are about two yards long and less than one inch wide. The number of shells per band varies; mostly there are between 75 and 100 shells on one band. They are used in the same payments as the *jao*, and may also serve as a payment for highly valued possessions like pigs. Odd shells are used to purchase lesser valued objects.

Cultivation and pig breeding provide the Wanggulam with most of their food. Hunting and gathering are practised on only a very small scale. Most daily activities are concerned with cultivation. On the basis of types of crops grown and length of time the tract is under cultivation, I distinguish three types of gardens: swiddens, hamlet gardens and pandanus orchards.

Swiddens are cropped once or twice and then left fallow for about eight to ten years. They are cropped primarily with sweet potato. Other crops grown on the swiddens include cassava, taro, sweetcorn, sugar cane, banana, cucumber and various types of beans. Hamlet gardens are cropped for a number of years, usually as long as a hamlet remains in existence. I am not sure if this type of cultivation is shifting in the sense that they 'are cropped for shorter periods in years than they are fallowed' (Conklin; 1961, p. 1), and hence I do not know whether these gardens also are swiddens. If so, they might be regarded as a sub-variety of the first type. In hamlet gardens are grown prized crops like banana, cassava, tobacco, ginger, several varieties of greens, and — now-

adays — crops like tomatoes and french beans. Pandanus trees bear fruit during more than one generation so that a pandanus orchard may exist for several decades. The orchards are usually small: Wanggulam think that rather flat and humid plots are required for growing pandanus, and in this rugged country, these are mostly small and scattered.

Wanggulam cultivation techniques are far less elaborate than those used in many other parts of the highlands. To prepare a tract for cultivation, the people merely clear the vegetation, either virgin jungle or regrowth, and burn the twigs and leaves, using the larger branches and the stems for firewood or fencing. Brookfield (1962) distinguishes six types of cultivation in the New Guinea Highlands. Wanggulam cultivation comes closest to the simplest type: 'Simple shifting cultivation dependent on bush fallow for soil-nutrient recovery; no tillage; no other form of soil-nutrient, erosion or water control' (Brookfield; 1962, p. 252). However, the last mentioned three forms of control are not entirely lacking.

There are domesticated pigs, dogs and cassowaries. Of these pigs are a focus of interest for the Wanggulam. They do not own very many; in 1962 Wanggulam owned on the average slightly less than two adult pigs per man. No man owned more than four. Pork is by far the most important animal food, both socially and dietetically. It is eaten infrequently and only on special occasions, the most frequent being wedding ceremonies.

Wanggulam know two methods of preparing food: roasting and steaming in earth ovens. There are two meals a day, one in the morning prepared immediately after people have got up, the other at about three or four o'clock in the afternoon. The morning meal consists mainly of roasted sweet potatoes. The afternoon meal, which is usually steamed, consists of sweet potatoes with other items of the diet. Much is eaten between meals. I would guess this amount may even exceed the amount eaten during meals. During my stay the Wanggulam looked well fed. I never noticed any insufficiency in the food provided during a meal. On the contrary, on many occasions people took leftovers away with them.

## CHAPTER 2

### KIN AND TERRITORIAL GROUPS

In this chapter I briefly describe the kin and territorial groups which form part of Wanggulam parish. I restrict this description to the more enduring groups and thus neglect those groups which gather for one or a few specific tasks and afterwards disperse again. I use the vague qualification 'more enduring' on purpose, since not all types of groups described remain in existence for a great length of time. Hamlet groups, the groups formed by people living together in a single hamlet, are especially unstable. In this chapter I mainly describe the size and the composition of the groups and go on in following chapters to discuss their economic and political functions.

By 'parishes' I refer to 'communities composed of persons associated with a certain tract of land, bearing a distinctive name, and forming a political unit' (Hogbin and Wedgwood; 1953, p. 253). Wanggulam parish territory is divided into several parts each of which forms the territory of a 'parish section'. The boundaries of the territories of parish sections are often not clearly demarcated in the terrain and they may shift over time. Section members are not the exclusive users of their section territory. Men often use land formerly used by their fathers but this does not occur always.

Parish sections are named and are exogamous. All members of a section, both men and women, are united by 'agnatic' ties (the reason for putting the word 'agnatic' in inverted commas will be discussed below). Most men live in the territory of their section and thus form part of the parish community. On the other hand, most of the women of the section, after marriage, do not live in the section territory. Instead they live with their husbands, either elsewhere in the same parish, or in other parishes. Thus, whereas most of the male members of the section, as well as being 'agnatic' relatives, are also united by ties of co-residence in the section territory, the female members of the section do not co-reside in this territory. Apart from their 'agnatic'

relationships, married female members are at the most united by co-residence in the parish territory. Not all female members are thus united since many women marry men belonging to other parishes and leave the parish to go and live with their husbands just as the 'foreign' women mentioned in table 1, p. 14, left their home parishes to come and live with their Wanggulam husbands. A section is the group concerned with activities like harvest feasts and on such occasions it is usually led by one of its members, who has achieved this position by qualities of fighting prowess, verbal skill and leadership capacity. Wanggulam refer to these leaders as *ap ngwok*. Literally translated these words mean 'big men' or 'a big man', designations I will use in the following discussions. A parish section is in many cases linked to several other sections located in other parishes. These links are conceptualised as vague 'agnatic' connections between the ancestors of the various sections. Members of linked sections do not intermarry. Their territories may be as far apart as a few days travel on foot. Sets of linked sections do not have common activities, but the individual members of different sections may have close personal relationships and may visit one other. The Wanggulam call these sets '*anembeno*'. They are inclined to regard the members of sections and *anembeno* as agnatically related, but they do not apply this view consistently. Sometimes they hold that a person can become a member of a section by co-residence with members and by participation in their affairs. At other times they hold the reverse, asserting that co-residence and participation in the affairs of the other members is not essential and that membership is restricted to agnatic relatives only. Thus a Wanggulam may say: 'XY has become a Penggu' and then in the next sentence: 'XY is not a Penggu, he has come from afar and Penggu is the section his mother belonged to'. The importance of agnatic relationships in the composition of the *anembeno* is reflected in an Omaha type kinship terminology in which MB is terminologically equated with MBS, M with MZ and with MZD, F with FB, and G with FBC; but in which FZ and Z, and MF and MB are terminologically differentiated.

In August 1962 there were four parish sections in Wanggulam. Their names were: Penggu, Karoba, Mabu and Ngopare. The four sections vary in size from 21 to 163 people (see table 1), but it should be noted that in this table 1 include only the Wanggulam members of the sections. Incoming 'foreigners' are shown separately, and members of sections who live outside Wanggulam are excluded from the table.

A fifth group, Wabit, does not have its own territory. It contains three

	men	women	children	total
Sections: Penggu	41	21	52	114
Karoba	51	29	83	163
Mabu	11	3	7	21
Ngopare	9	3	14	26
Wabit	3		5	8
"foreign" women		80	7	87
"foreign" families	24	13	28	66
totals	119	149	197	485

TABLE 1: COMPOSITION OF WANGGULAM PARISH

adult male members who live dispersed over Wanggulam territory. The sections intermarry, but there are also marriages with non-Wanggulam. Accordingly the parish includes 80 'foreign' women and 7 'foreign' children. All 80 women are the wives or widows of Wanggulam men and I call them 'foreign' because they belong to non-Wanggulam sections. The group contains a number of 'foreign' children because some Wanggulam men have married widows with young children whose fathers belonged to other parishes; these children live with their Wanggulam step-fathers. Finally there are a number of 'foreign' men with their wives and children. I took as 'women' all females who were or had been married and as 'men' all males usually sleeping in a men's house, whether married or not. This usage follows Wanggulam categorisation: a married woman is referred to by *kwe*, an unmarried girl by *kwuliga*. A young man who uses to sleep in a man's house is called *ap*, a boy sleeping in a woman's house *wuliga*.

The two large sections are divided into sub-sections. Within Karoba there are three sub-sections referred to as '(the descendants of) the first born son', '(the descendants of) the second born son', and '(the descendants of) the third born son' (see table 2. The sub-sections are indicated as K I, K II, and K III). Within Penggu there are five sub-sections each referred to by the names of their most prominent male members. In table 2 the Penggu sub-sections are indicated as P a, P b, and so on. Wanggulam distinguish sub-sub-sections within K II and K III, but not within K I. K II is divided into two groups referred to in the same way as the Penggu sub-sections, that is to say by the names of the most prominent male members. The members of K I are not classified into a number of sub-sub-sections but there are distinctions made between more closely and more distantly related 'agnates'. When differentiating members of different sections, people may refer to the

	section		children	total	sub-section		sub-sub-section		
	men	women			men	women	men	women	children
Punggu	41	21	52	114	P a	4	4	3	
					P b	9	5	4	
					P c	11	3	15	
					P d	9	4	16	
					P e	8	5	14	
Karoba	51	29	83	163	K I	31	16	46	
					K II	7	7	27	K IIa 5 K IIb 2
					K III	13	6	10	K III 11 Mbula 2
									6 15 1 12 5 10 1
Mabu	11	3	7	21					
Ngopare	9	3	14	26					
Wabit	3		5	8					
foreign women		80	7	87					
foreign families	24	13	29	66					
Totals	139	149	197	485					

TABLE 2: COMPOSITION OF WANGGULAM PARISH IN DETAIL

fact that they are 'of different penis gourds', or of 'different ancestors', but they may also simply say that people belong to different groups because they (these people) are 'different'. Genealogical differentiation is often assumed but not traced out step by step. Even small groups like sub-sections of Penggu or sub-sub-sections of Karoba II may lack remembered unitary genealogical structures. When people do try to trace the relationships between members of such groups, they rarely go back further than three generations and they do not trace the relationship back to a single apical ancestor but rather to a group of brothers.

Barnes (1962) argues that among most New Guinea Highlands peoples the notion of descent is absent or only weakly held. The members of patrilineal groups in the New Guinea Highlands are, according to Barnes, not necessarily united because they are the descendants of a common agnatic ancestor. They have become members because their fathers were or still are members. This recruitment on the basis of patrification repeats itself in the course of the generations. The resulting group

may be similar in demographic appearance and *de facto* kinship ties to a patrilineal group in which accessory segments are continually being assimilated to the authentic core, but its structure and ideology are quite different. (Barnes; 1962, p. 6).

Yet the Wanggulam do differentiate members of different groups in terms of their descent from different ancestors. They would seem therefore to recognise the notion of descent, be it weakly. On the other hand people do not seem to exclude consistently the possibility of a man, whether a non-agnate or a non-cognate, becoming a member of a section solely by co-residence with its members and by participation in their activities.

This inconsistency bears on a terminological problem. In the following discussion I will refer to *anembeno* and sections as agnatic groups and to individuals and their agnatic and cognatic relatives, without putting the terms 'agnatic', 'patrilineal' and 'cognatic' in inverted commas. I realise that there are theoretical objections to this usage in so far as such so-called 'agnatic' or 'patrilineal' groups may contain people who are non-agnates, and in so far as some so-called 'agnatic' and 'cognatic' relatives may be respectively non-agnates and non-cognates, but a terminology accounting for the complexities underlying the composition of *anembeno* and sections would be a cumbersome one. Because of the agnatic orientation apparent with *anembeno* and sections

I will retain the terms agnatic, patrilineal and cognatic, without inverted commas, while remaining aware of those features of Wanggulam social structure which might give rise to objections to this term. To restrict the number of terms used without their carrying their exact meaning, I will use the term *anembeno* rather than clan, and the term section rather than lineage. There are two additional reasons for using the term section: firstly, there are some sections the members of which cannot trace out all their mutual genealogical links. Secondly, the sections of one *anembeno* do not form an agnatically linked, territorial and political unit as the lineages of a single clan do in many societies. Sections form part of parishes and there are no agnatic links between the sections of one parish.

Penggu and Karoba are not only numerically prominent, they are regarded as one unit, named Penggu-Karoba, which is often identified with Wanggulam, although the parish includes other groups. Penggu and Karoba form one unit because they *ogunakwe*, that is to say because they 'give each other their women', which I indicate by calling them each other's 'ally'. *Ogunakwe*, exchanging of women between two sections, does not necessarily lead to the formation of a unit identified with a parish: Mabu and Karoba *ogunakwe*, but the Wanggulam do not speak about Mabu-Karoba, because Mabu is only a small section. Because of the prominence of Penggu and Karoba, I will refer to them as the main sections of Wanggulam.

As already has become apparent in the beginning of this chapter, Penggu-Karoba is not a truly endogamous group, as the ideal marriage procedure implied by the concept of *ogunakwe* is not always followed. It appears that during the period from about 1930 to 1962 almost half of the marriages contracted by Penggu and Karoba women were with Karoba or Penggu men respectively. On account of these and former Penggu-Karoba marriages, most members of these sections can trace cognatic relationship with each other. Another implication of the frequent intra-parish marriages is that a man and the children of many of the female members of his section are members of the same parish and live in close proximity. Wanggulam consider there is a strong link between a man and the children of the female members of his section, especially his sister's children. Their common parish residence facilitates the expression of this relation through a great deal of interaction.

The group of people actually living together on a section territory I call a 'vicinage'. Analysis of the kin relations between the members of a vicinage yields the following result.

There are, firstly, a number of agnatically related men, together with their sons and unmarried daughters. These people are thought of as agnatic descendants of the section ancestor.

Secondly, a very small number of adult women, also agnatic descendants of the section ancestor. Either the husbands of these women live uxorilocally, or they themselves have returned to their natal section after a divorce or after the death of their husbands. I will refer to the people included in the first and second categories as section members.

Thirdly, the wives of married male members. A number of these women have been born and reared in the parish of which the section forms a part but the majority has come from other parishes as brides.

Fourthly, a number of other men with their sons and unmarried daughters. These people are said not to be agnatically descended from the section ancestor. They themselves or their agnatic ancestors have been members of another section. I will refer to these people as associates.

Fifthly, and finally, the wives of married associates.

Associates are either agnatically descended from the ancestor of a 'foreign' section, that is to say a section having its territory in another parish than Wanggulam, or they are agnatically descended from the ancestor of one of the other Wanggulam sections. I will refer to the first category of associates as 'foreign associates'.

Association, in this sense, may also be explained by reference to a relation between sections. For instance, Wanggulam may say that the Ngopare came to live in Wanggulam parish because they and the Penggu *ogunakwe* or because the Ngopare are the children of the female members of Penggu section. Ngopare section has been with the Wanggulam only a few years and the people do not know whether those Ngopare who did not leave Wanggulam territory during 1960-1962 will stay permanently. The Ngopare have a very indeterminate territory. It is said that they live 'upstream, near the Luaga', and the exact location of their future gardens is not known.

In August 1962 there was a total of 33 adult and adolescent male foreign associates of whom nine were Ngopare, representing 23.0 % of this category of the Wanggulam population. Of the 33 males, 29 were born as members of other parishes and came to Wanggulam later in life.

There were further associates whose remembered agnatic ancestors founded Wanggulam sections, but who did not live in the territory of

their ancestral sections. In August 1962 this category of associates included 20 adult and adolescent males, 15.0 % of this part of the Wanggulam population.

In general all associates are said to be kin or affinal relatives of one or more Wanggulam. I know that in three cases no physical connexion exists. These cases involve feeble minded men each associated with a man on whom he is dependent, and who is referred to as his 'false + B'. The latter provides his client with shelter and food, on the other hand using him — as far as possible — for all kind of jobs. The feeble minded men are referred to as the *eiloman* of their false + B's.

Unlike sections, sub-sections may or may not be clearly demarcated spatially. In Wanggulam they are demarcated when they belong to the category referred to by names like 'first born son', whereas they are not when they belong to the category referred to by the names of their most prominent male members. Because I have no examples of the detailed organisation of other parishes, I do not know whether or not this difference is accidental. The residence pattern of the Karoba is conceived by the Wanggulam as modelled upon the existence of three distinct and contiguous territories (one for Karoba I, one for Karoba II, and one for Karoba III together with Mbula; see map III). The sub-sub-sections within Karoba II are not thought of as having distinct territories. In all three cases this is in accordance with the actual residential situation.

The distinctness and contiguity of the three Karoba sub-section territories is blurred by a number of exceptions. These occur also in the residence pattern: the dwellings of the male members of the three sub-sections are neither locally distinct, that is to say they are not erected upon separate localities, nor fully localised, that is to say they do not cluster together (Reay; 1959, p. 38). It turns out that of the 53 adult and adolescent males living on their own sub-section territory, 17 (32.1 %) were Karoba living on the territory of another sub-section; two (3.8 %) were associates from Wanggulam sections; eight (15.1 %) foreign associates. Four Karoba adult and adolescent males, together with two Penggu associates, lived in an area only recently occupied by Karoba people. Four lived as associates of other Wanggulam sections. In total there were 51 Karoba Wanggulam adult and adolescent males of whom 26 (51.0 %) were living on their own sub-section territory. There is no explicit preference for residence in one's own sub-section's territory, nor — in the case of Karoba — in one's own sub-sub-section territory. People's comments would suggest that residence outside one's



In 1961 there were among the Wanggulam 21 groups of two or more adult and adolescent full brothers, numbering 54 persons. If adult and adolescent full brothers were always to live together in one hamlet, the groups would have 21 residences, and — if each brother lived on his own — they would have 54 residences. The trend to live separately was most pronounced in the large (sub-)sections: Penggu and Karoba I, and less in the smaller (sub-)sections: Mabu, Karoba II, Karoba III with Mbula, and Ngopare. I thought that this was because the larger territory of the larger group provided larger freedom of movement, but during 1961 and 1962 the contrast between the large and the small (sub-)sections became less pronounced, as a result of an even greater dispersion.

In one case only, the brothers were on bad terms and avoided each other. It was often said that the immediate reason for a separation had been a quarrel, but after good relationships had been resumed, the men did not consider it necessary to take up common residence again. Others did not comment unfavourably upon this behaviour.

The figures presented above show the extent to which local groups like the vicinage and its subdivisions include persons other than section, sub-section or sub-sub-section members, their wives and children; that is to say they show the extent to which vicinage membership departs from a 'patrivirilocal model'. However, the categorisation I made on pages 17-18, does not completely account for the pattern of interaction between section members and associates. Among the Wanggulam social relations are maintained by a flow of prestations and counter-prestations, while the absence of such a flow of prestations points to the absence of a close relation. Hence participation in the affairs of the host section and non-participation in the affairs of other sections indicate close and exclusive relations with the host section and thus a large measure of incorporation within it. Some associates are so much incorporated into their host section that they appear to be true members, others much less so. Foreign associates are often more fully incorporated into their host section than Wanggulam associates, largely because the latter can more easily maintain relations with the section they or their agnatic ancestors belonged to. For foreign associates it is more difficult to maintain such relations because of the large social distance between the parishes concerned. In chapters 6 and 7 I will present a detailed description of an oil pandanus feast organised by, as the Wanggulam said, Penggu section. Foreign associates, for example the Ngopare, took part in this feast, while the Karoba associates of Penggu section did not. They told me that they intended to take part in a feast later to be

organised by Karoba section. This might well have been true since the Penggu associates of Karoba section took part in the Penggu pandanus feast. Unfortunately I could not check the statements of the Karoba since their section did not organise a feast at all, for it was thought that the missionaries would disapprove of it.

Other factors which influence the measure of incorporation within the host section are the length of time during which interaction between associates and their hosts is maintained and, secondly, the degree of likelihood that it will be broken off. For instance, complete, or all but complete, incorporation occurred in the case of a group of Penggu associates of Penggu section. Their FF or a further removed agnatic ancestor, people do not remember who, was a member of a Penggu section of one of the other Mbogoga parishes. After this man's death, his widow remarried a Wanggulam Penggu. The agnatic descendants of her first husband do not maintain relationships with the section he belonged to. Instead they take part in all affairs of Wanggulam Penggu section and some of them have a very high status among the Wanggulam. When people list the composition of Penggu section, these associates are often included as members. I hesitate to state that they are completely incorporated in Penggu section because people remembered that they were not agnatically descended from the ancestor of this section. I have no data which indicate that they were in any way discriminated against. This situation contrasts with the situation among the Enga where non-agnates are discriminated against (Meggitt; 1965, p. 44).

I continue the discussion of the local groups with an analysis of the composition of hamlet groups. In May 1960 there were 34 hamlets in Wanggulam parish, with on the average one men's house and 3.0 women's houses. The number of women's houses ranged from one to six. The number of inhabitants was on the average 15.4 and ranged from three to 43. The mean number of inhabitants of a men's house was 4.8, the mean number of inhabitants of a women's house 3.5. In the 27 months between May 1960 and August 1962, 16 new hamlets were built and 12 were left so that the mean span of time a hamlet remains in existence is probably not more than three or four years. Moreover, people move frequently from one hamlet to another.

The people living together in one women's house are ideally one married woman, her unmarried daughters and her pre-adolescent sons, while her husband and her adolescent and adult sons sleep in the men's house in the same hamlet. Actually the group living in one women's

house may include others, for instance a co-wife, may be with children, or a younger sister of her husband or orphaned children. In March 1961 there were 101 women's houses among the Wanggulam, about 98 of which I have conclusive data regarding the number and kin connexions of the inhabitants. In 41 cases, 41.9 % of the cases, the group was composed in the ideal way as mentioned above. In 25 cases (25.6 %) single persons were attached to this group. In the rest of the cases the group centered upon more than one married couple.

## CHAPTER 3

### MAINTENANCE OF SOCIAL RELATIONSHIPS

#### I

In this chapter I indicate the way in which the Wanggulam maintain social relationships by making prestations and counter-prestations. They explain the present rights and obligations they have towards each other as resulting from former prestations and the idea of a relationship not validated by a flow of prestations seems foreign to them. A Wanggulam man expressed this by saying: 'When you stop giving each other things, you soon drift apart'. Analysis of rights and obligations as they actually occur between kin or neighbours often shows that they do not arise from the kin relationship or co-residence only, but that they too are links in a chain of reciprocated prestations. Nor, for instance, is the size of the prestations between kinsmen determined by their positions in the system of kinship relationships. However, it seems to me that the Wanggulam are inclined to overemphasise the extent to which they are free to decide for themselves whether or not to render prestations towards kin or neighbours. A man who decides not to render prestations is likely to suffer disadvantages. If he needs help, his kin and/or neighbours may well be unwilling to render prestations to him. Furthermore his kin and neighbours may distrust him, interpreting his uncooperativeness as a sign of disfavour. Finally, one important category of prestations consists of contributions to wedding payments and compensations. A man who consistently fails to contribute to these payments is regarded as a starveling and is held in very low esteem.

To show the flow of prestations occurring between the Wanggulam I use a number of regularly recurring events: the opening of swiddens and small harvest feasts, discussed in section II of this chapter, and wedding ceremonies and cremations, discussed in section III. These are not the only occasions providing the Wanggulam with opportunities to render each other prestations: other events such as fights and raids, assembling of compensations and pigfeasts are discussed in later

chapters. In the final section of this chapter, section IV, I estimate the amount of prestations rendered on account of wedding ceremonies discussed in section III.

## II

The opening of new swiddens is often concentrated in the drier season from June through August. This happened for instance in 1960, but in 1961 and in 1962 the work on the swiddens was more spread out, in 1961 because too much rain fell during the middle of the year and in 1962 because the Wanggulam were preoccupied with an upsurge of the religious movement. If, as in 1960, many men start opening new swiddens in the course of a few weeks, the Wanggulam have a busy and festive time during which there is a great deal of economic cooperation.

The actual work consists of clearing the tract, burning branches and leaves, and building a fence if it is necessary to prevent pigs from entering the area. Much of this work is done by teams of men, who come together at the request of the cultivator or cultivators, on whose swiddens they are to work. The work is regarded as a prestation which the organiser or organisers of the work have to reciprocate. During the day they offer tobacco to their workers and, when the work is finished, they offer them a meal. A few days or weeks later, the organisers join teams gathered together in the same way by one or a few of their former workers. A work party may be organised at any stage of the opening of a swidden. The last team does weeding or finishes building the fence around the swidden, a task that may be completed several weeks after the swidden has been planted. When the first crops of the swidden are harvested, the workers who contributed to its opening are remunerated at a small harvest feast organised by the holder of the swidden. Most adult men organise, either alone or jointly, at least one work party during the opening of their swiddens. The number of workers in a party varies greatly. It depends primarily on the number of the men organising the party. When one man organises a party, he is often helped by 3-4 men. When several men opening a complex of swiddens organise a party, there may be as many as 20 or more helpers.

Work parties are also formed to build or repair houses or hamlet fences. The organisation is identical with those of the swidden parties.

In this case too the organiser of the team offers tobacco and a meal to his workers. Counter-prestations may not be made as promptly as in the case of the parties formed for garden tasks since work on hamlets and houses recurs less regularly. Most of these jobs are done after the harvest feasts and before the opening of new swiddens.

The Wanggulam themselves point out the reciprocity which links the prestations. The meal offered by the organiser of the work is sometimes called *onggo*, the 'price' or the 'payment' of the labour offered by the workers of the team. Workers are said to be invited to a harvest feast, 'because' they have contributed towards the opening of the garden. Finally I stress that the prestations and counter-prestations do not consist of pairs of identical activities, but rather of sequences including prestations differing in content: offering of labour and offering of food and/or tobacco.

My data do not allow a calculation of the mean number of times Wanggulam men take part in working parties. From 22 June 1960 until 31 December 1960 I witnessed 31 work parties. I know more parties have been organised among the Wanggulam during this period, but I do not know how many. Hence the following calculation of the frequency of working parties during the mentioned period is an underestimate.

Since Sundays were kept as a day of rest (see p. 58), work parties were organised only on week days. During the period mentioned there were 165 such days. Moreover I was absent from Wanggulam during 12 out of these 165 days. I do not know whether parties were organised during these 12 days. Hence the 31 parties I witnessed took place during a total of 153 days. During the same period at least 13 harvest parties were held remunerating helpers at work parties. As far as I know the party on 22 June was the first of the 1960 swidden opening season. The first of the 13 harvest parties was held on 12 September and was organised by Wandin, one of the men who had organised the work party on 22 June.

I have fairly precise data on the number of organisers and helpers in 12 of the 31 parties. The mean number of helpers per party was 6.0 and the mean number of helpers per organiser is 2.7.

However I do not know how these figures relate to the mean number of parties taking place among the Wanggulam in the course of one year and the mean number of helpers during these parties. Firstly, I do not know what proportion the work parties mentioned formed of the total number of parties held during the period 22 June 1960 until

31 December 1960. Secondly, I do not know what proportion the work parties held during this period formed of the work parties held in the course of the year following 22 June 1960.

### III

A more complicated series of prestations is centered upon wedding ceremonies. The ceremonies imply ceding a woman by one group of people to another group of people who then can benefit from her industry and reproductive power. This prestation leads to a number of other prestations: the man who reared the bride, usually her father, assembles a payment called *uak*, and the man who reared the groom, usually his father, assembles a payment called *kwe onngo*. A few Wanggulam children are reared by relatives other than their father, and the man who reared a child may have become incapacitated or have died before his or her wedding takes place. However, for simplicity, I refer below to the father of the bride and the father of the groom as the assemblers of the *uak* and the *kwe onngo* respectively, and as the organisers of the accompanying ceremonies. I did not hear the word *uak* in another context and I cannot translate it. *Kwe* means 'woman' and *onggo* means 'counter-prestasion', 'price' or 'payment', so that the name of the second payment might be translated as 'bride price'. The payments consist of *jao*, shell bands, and odd cowrie shells. During my second field trip one or a few steel axes or other steel implements formed part of a number of payments. The bride price contains moreover one or a few pigs. Only a small part of the payments is given by the fathers of the bride or groom; most is contributed by other relatives. In both cases the bulk of the payments is contributed by patrilateral relatives, in the case of the *uak* by the patrilateral relatives of the bride, in the case of the bride price by the patrilateral relatives of the groom. Tables 4 and 5 show the size of a number of payments which were assembled during my stay among the Wanggulam. They show the amounts contributed by the father and several other categories of relatives of bride and groom. I center the categories of kin relationships on bride and groom, and not on the assembler, since this method of categorisation is applied by the Wanggulam themselves. Tabulated are only the 'large items', that is to say *jao*, shell bands (referred to by 's.b.'), pigs and steel implements (referred to by 'st.i.'). The letters of the cases refer to the girls for whom a specific *uak* or a specific

	category of item	item contributed by					totals
		cognatic relatives			affines	not known	
		nuclear family	other pa-trilateral kin	other ma-trilateral kin			
Case A	jao	6	25	10	1	3	45
	pig	2	1	1			4
	s.b. a)	2	13	5	1	3	24
B	jao	2	20	3		4	29
	pig	2	1				3
	s.b.		12	1		3	16
C	jao	1	13			1	15
	pig	1					1
	s.b.	2	7				9
D	jao	2	8	7		3	20
	pig	1	1				2
	s.b.	1	1	5		1	8
E	jao	5	8	5			18
	pig		1				1
	s.b.	1	8	2			11
F	jao	2	34	1		4	41
	pig	2	2				4
	s.b.	2	30	2		2	36
	st.i. b)		3				3
G	jao	3	40	3	2	1	49
	pig	2	2				4
	s.b.	2	29	2	1	4	38
H	jao	4	24	1	1	1	31
	pig	?	?	?	?	?	?
	s.b.	2	22			2	26
I	jao	2	21	4		2	29
	pig		4				4
	s.b.	1	14	2			17
	st.i.		2				2
mean numbers of contributions	jao	3.0	21.4	3.9	0.4	2.1	30.8
	pig	1.3	1.5	0.1			2.9
	s.b.	1.4	15.1	2.1	0.2	1.7	20.5
	st.i.		0.6				(20.6) 0.6

a) s.b. stands for 'shell band'.

b) st.i. stands for 'steel implement'.

TABLE 4: CONTRIBUTIONS TO *UAK* (Bride's father's prestation)

	category of item	item contributed by					totals
		nuclear family	other pa-trilateral kin	other ma-trilateral kin	affines	not a) known	
Case F	jao	4	25		1	8	38
	s.b. b)	3	14		1	3	21
J	jao	4	9			10	23
	s.b.	2	6	1			9
K	jao	3	7	2		9	21
	s.b.	1	5	2		7	15
L	jao	7	19			6	32
	s.b.	2	4			1	7
M	jao	8	13			2	23
	s.b.	2	3			1	6
N	jao	3	9	2			14
	s.b.	2	10	5			17
	st.i. c)	1					1
mean numbers of contributions	jao	4.8	13.7	0.7	0.2	5.8	25.2
	s.b.	2.0	7.0	1.3	0.2	2.0	12.5
	st.i.	0.2					0.2

- a) The items of a bride price are brought together immediately before it is transferred and distributed. Accordingly there is not much opportunity to inquire about the source of the contributions. In several cases I did not inquire about the donors of the pigs. In those cases where I did get information on this matter, including some not represented in the table, the pigs were contributed by close agnatic relatives only, except in cases K and N. In these two cases the grooms were living with their mother's section, members of which in case K contributed two pigs, and in case N one pig, in both cases out of a total of three pigs.
- b) s.b. stands for 'shell band'.
- c) st.i. stands for 'steel implement'.

TABLE 5: CONTRIBUTIONS TO BRIDE PRICE  
*(Kwe onngo, groom's father's prestation)*

bride price is assembled. In case F only I have detailed data on both *uak* and bride price.

Wedding ceremonies as I witnessed them during my field work consist of at least three parts, held at intervals of one or a few days. Assembling the *uak* takes place during the first part of the ceremonies when the bride is dressed in a skirt of the type worn by married women only. Many visitors come to attend the ceremony and all bring a contribution to the *uak*. Women may also contribute little clews of the string from which the skirt is made. The father of the bride remunerates the contributors with pork, slaughtering about two or three pigs.

The next part of the ceremonies is the distribution of the *uak*. This is given to those who contributed to the *uak* of the bride's mother, or their heirs. The distribution is sometimes delayed until after the bride has been brought to the hamlet of the groom. She goes there accompanied by a group of mainly patrilateral relatives. After arrival the bride's party is offered food, sweet potatoes and sweet potato leaves, while the father of the bride offers pork. After the meal the father of the groom transfers the bride price to the father of the bride. Wanggulam say that this payment should match the *uak* exactly and it should also comprise as many pigs as the father has killed, firstly to remunerate the contributors to the *uak* and secondly to provide pork at the meal in the groom's hamlet. Nevertheless in a number of cases that I saw the bride price was smaller than the *uak*. I was told that in these cases the bride price would be supplemented later on, but I was never able to find out if and how this happened. I emphasise that in tables 5 and 6 are listed the size of the bride prices at the time of their public transfer in the course of the wedding ceremonies. Later on other items may have been added. Table 6 lists *uak* and bride price pairs assembled for the same bride. The cases are lettered as in tables 4 and 5. In cases A and F bride price is much smaller than the *uak*. Both marriages were short-lived. In one case the fathers of bride and groom agreed to store the valuables until the father of the groom had assembled additional *jao* and shell bands. When, after a number of months, he had not succeeded, the father of the bride reputedly brought his daughter back to his hamlet. In the other case the same happened after only a few weeks. I combined the *uak* and the bride prices assembled in cases D and E since in these two cases the wedding ceremonies were combined. The *uak* were assembled on the same day and in the same hamlet and a few days later the two bride prices were assembled, again in one hamlet. I did not get an opportunity to ask

		size <i>uak</i>	size bride price assembled during the wedding	
Case A	jao	45	22	
	s.b. a)	24	10	
	pig	4	4	
C	jao	15	20	
	s.b.	14	11	
	pig	1	1	
D	jao	20	38	
	s.b.	8	jao	41
	pig	2	s.b. 19	11
E	jao	18	pig (3)	2
	s.b.	11		
	pig	1		
F	jao	43	38	
	s.b.	36	21	
	pig	4	4	
	st.i. b)	3		
I	jao	29	35	
	s.b.	17	19	
	pig	4	4	
	st.i.	2	2	
O	jao	38	38	
	s.b.	10	14	
	pig	2	5	

- a) s.b. stands for 'shell band'.
- b) st.i. stands for 'steel implement'.

TABLE 6: COMPARISON OF THE SIZE OF AN *UAK* ASSEMBLED FOR A GIRL WITH THE SIZE OF THE BRIDE PRICE ASSEMBLED DURING HER WEDDING

which *jao* and shell bands formed part of D's bride price and which formed part of E's bride price. The pigs provided by the father of the bride are also listed in tables 4 and 6, although it is not clear whether or not they belong to the *uak*. Wanggulam say that the *uak* and the bride price for a girl should be the same. Since the bride price includes pigs, this statement implies that the *uak* also includes pigs. On the other hand they say that the *uak* is distributed to matrilineal relatives of the bride. During this distribution only *jao* and shell bands are

handed out, whereas the pigs assembled by the father of the bride during the first part of the wedding ceremonies are slaughtered and the pork is distributed to patrilineal relatives of the bride. This seems to indicate that the *uak* does not include pigs.

After the bride price has been transferred, it is sometimes immediately distributed to the contributors to the *uak*, sometimes one or a few days later. The sequence of prestations is schematically shown in figure 2. The donor of a prestation is shown at the head of the column in which the prestation is listed. The arrows show to whom the prestations are rendered.

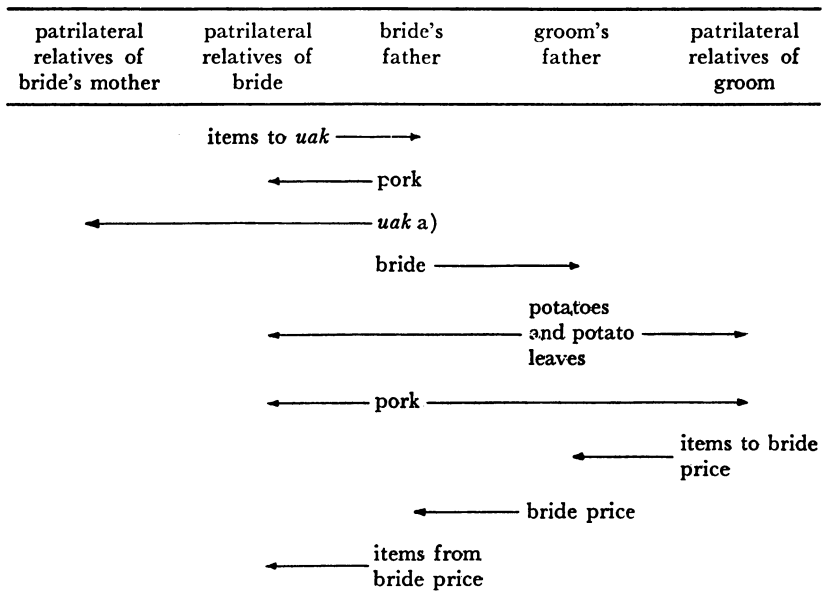

a) The distribution of the *uak* may also be the last prestation of the series.

FIGURE 2: SEQUENCE OF PRESTATIONS DURING  
A WANGGULAM WEDDING

It should be noted that in the case of an alliance, as between Penggu and Karoba, the sequence of prestations as shown in figure 2, is one in a series of sequences of prestations. Among the Wanggulam for instance 13 weddings between Penggu and Karoba partners took place from May 1960 (at the beginning of my first field trip) until August 1962 (at the end of my second field trip).

The father of the bride does not get an immediate return for ceding his daughter. He gives the bride price to the contributors of the *uak* for the bride and keeps only as many items as he himself has contributed; subsequently he has to distribute the whole of the *uak* for the bride to those who contributed to the *uak* for his wife, the bride's mother. Figure 3 shows the flow of the payments associated with the weddings of a woman (A) and her daughter (H). It shows that A's father (C) has to wait until the wedding of his daughter's daughter in order to receive valuables compensating him for ceding his daughter. Thus, while a man does not receive any valuables unless his daughter bears female offspring, he may receive several sets of valuables if his daughter bears more than one daughter.

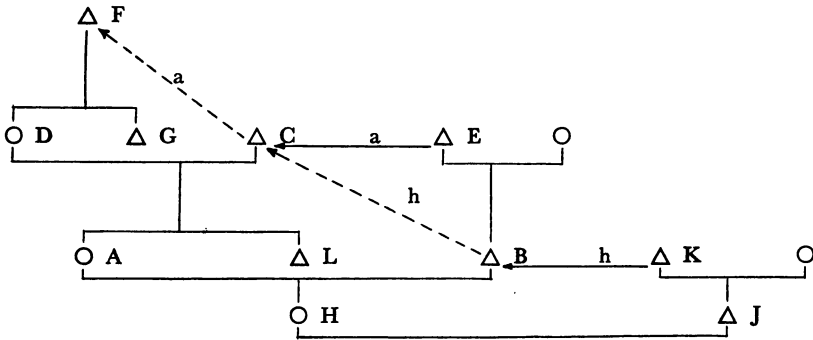

The figure is a schematic representation of the flow of payments and shows only the main participants.

- ← a — Bride price assembled by E and his kin and distributed to C and his kin. for A,
- ← - a - - - *uak* for A, assembled by C and his kin and distributed to F, or, if he has died, to G and to other patrilineal relatives of D.
- ← h — bride price assembled by K and his kin and distributed to B and his kin. for H,
- ← - h - - - *uak* for H, assembled by B and his kin and distributed to C, or, if he has died, to L and to other patrilineal relatives of A.

FIGURE 3: FLOW OF PAYMENTS ASSEMBLED AND DISTRIBUTED DURING THE WEDDINGS OF A MOTHER AND HER DAUGHTER

Wanggulam say that the *uak* is brought together by the members of the bride's section and by the sons of the female members of the section. They say that the bride price is brought together by the same classes of relatives of the groom. Tables 4 and 5 show that the principal part of the *uak* and bride price is brought together by patrilineal relatives. The cases in which matrilineal relatives contribute a considerable amount all show unusual features.

In case A part of the *uak* was contributed by the members of the section of the girl's MM, who had been a Wanggulam. The girl's father had died. He had not been a Wanggulam. After his death the girl's mother had remarried and the girl's stepfather, also a Wanggulam, had also assembled part of the *uak*.

In case D the girl lived together with her elder brother in the hamlet of her BWF. This man belonged to the same section as the girl's mother. He, his close agnates and their descendants contributed to the *uak*.

In case E the girl lived together with her elder brother in the hamlet of their MKB. This is also unusual, for girls usually live together with their agnates. In this case the girl's MKB, his close agnates and their descendants, contributed to her *uak*. In all other cases the girls lived together with their agnates.

There do not seem to be rules specifying which relatives are obliged to contribute and with what items. People said that the father of the bride or the groom does not know beforehand which people will contribute. Inquiries made during wedding ceremonies, and about ceremonies that had been held before I started field work, showed that Wanggulam regard contributions to the payments as counter-prestations and judge sufficiency or insufficiency of contributions by reference to the former prestations.

The cremation payment is assembled and distributed just before the cremation of a deceased. It is called *inggo*, a word I cannot translate. It is much smaller than the wedding payments and consists of a few *jao*, a few shell bands, odd cowrie shells and may be one pig. I have no exact data as to its size because often the relatives of the deceased could not or did not want to produce the required *jao* and shell bands at the time of the cremation so that their transfer was postponed and did not occur in public. The payment is made to the contributors to the *uak* of the deceased's mother, that is to say to the recipients of the bride price for the deceased's mother. Among the Enga the 'death compensation' is often paid to the same category of people (Meggitt;

1965, p. 204). Among the Wanggulam others often receive of the cremation payment, for instance people who have rendered prestations in regard of the cremation.

Thus I argue that the individual transactions between the assembler and the contributors, and the assembler and the recipients are links in a chain of prestations and further that the payments in their entirety are also counter-prestations: an *uak* for a bride is a counter-prestation for the *uak* of the bride's mother, a bride price is a counter-prestation for the transfer of the bride, and a cremation payment is a counter-prestation for the *uak* for the deceased's mother or at least contributions to the deceased's mother's *uak*. We may ask however what prestations the transfer of the bride entails and further whether the transfer of an *uak* serves functions other than merely reciprocating a former *uak*.

I did not succeed in eliciting straightforward answers from the Wanggulam about the prestations entailed by the transfer of the bride. A number of times people told me that such-and-such a man 'copulated for nothing', since he had not paid a bride price. Once I was told that a woman had left her husband criticizing him that he 'copulated with her for nothing', since he had not paid a bride price for her. In a number of cases it appeared that a man who had married a widow with a daughter by a previous marriage had not paid a bride price since, as I was told, he would have to assemble the *uak* for the daughter. In one of these cases the woman also had a son by a previous marriage. Her second husband had contributed only one shell band to the *onggo* for this son's wife. However, he said he had not asked for repayment, because his wife had rendered him economic services.

These data indicate that transfer of the bride price to the groom implies at least two prestations: it provides the groom with the right of sexual access to the bride and hence gives him the possibility of acquiring offspring. However, it seems that, if the bride proves to be barren, the groom or his father cannot claim a refund of the bride price or the transfer of another bride.

I did not come across any case in which section membership of a child was contested because of non-payment of the bride price for its mother. There were two cases in which I heard a man complaining that only part of the bride price had been transferred although his daughter had already born offspring; in one case one child, in the other two children. The father did not claim his grandchildren as members of his own section, but merely complained that his son-in-law was copulating for nothing. It seems then that rights *in geneticem* are held by the

groom and his section irrespective of the transfer of the bride price, while sexual rights *in uxorem* are acquired by the transfer of the bride price.

Wanggulam could not tell me why they thought the *uak* for a bride had to be distributed to the contributors to the *uak* of the bride's mother. We might argue along these lines: a girl's wedding is organised by the man who reared her, normally her father, and he may choose a husband for her, although he cannot easily force the girl to accept the man he has chosen. Wanggulam say that a girl is given to her husband by her father, or by her father's section, even if in fact the girl herself has chosen her husband. Her mother's section normally has no say in the matter, although there is a strong link between especially a mother's brother and his sister's children. This link may be based on the consideration that the mother's brother and other members of her mother's section have contributed to the *uak* and thus made it possible that her marriage came into being and that she bore children. The distribution of a girl's *uak* to the contributors to her mother's *uak* might therefore be regarded as a compensation for an act of unilateral disposal, namely ceding her to her husband and his section. In line with this explanation is the fact that, if the *uak* is not distributed in the way I have described, the girl's mother's brother, or another member of her mother's section, may try to abduct her to make her come to his hamlet, to marry her off himself.

However, I hesitate to put forward this explanation, since, if the preferential marriage pattern is followed, the girl is married to a member of the section her mother belonged to. In this case her mother's section benefits from the wedding and there is no reason to compensate it. Secondly, the explanation would be the more satisfactory if it would cover both the *uak* and the cremation payment. The latter payment is distributed to the members of the section of the deceased's mother. The cremation might also be regarded as an act of disposal, but it is not easy to see why the contributors to the *uak* for the deceased's mother should be compensated for this act of disposal. Among Highlands peoples the members of the mother's patrilineal group may accuse the members of the patrilineal groups of the deceased of neglecting (Brown; 1961, p. 90) or of not properly protecting (Meggitt; 1965, p. 195) the deceased so that he died. A payment made to the matrilineal relatives of the deceased may then be regarded as a compensation for the loss due to this neglect. Among the Wanggulam such accusations are not made. It seems that among them the distribution of the payment entitles

the members of a section to cremate their deceased member. A few times I was told that in case of non-payment or insufficient payment, the members of the deceased's mother's section reproach the members of the deceased's section saying: 'You have cremated the child of our female member for nothing'. Once I observed that a woman tried to prevent people from carrying the corpse to the stake since she felt that she had not received enough during the distribution. Because of the association between payment and cremation, I refer to the payment as a 'cremation payment' and not as a 'death payment'.

#### IV

In this section I estimate the frequency with which people take part in the exchange of *jao*, shell bands and pigs. Contributions to wedding, cremation and compensation payments are made by individuals, either men or women. This corresponds with the important place of the nuclear family in Wanggulam economy, and the unimportance of groups like sections and sub-sections, vicinages and their constituent parts. There is a marked sexual division of labour among the Wanggulam. Husband and wife perform complementary economic tasks, so that they form a close economic unit, both for production and for consumption, and also in the ownership of valuables like shell bands and *jao*. Contributions to payments made by an adult excuse his or her spouse and their young children from contributing on that occasion. Usually only one item is contributed, sometimes two and very rarely more than two. Adolescent boys start taking part in the exchange of valuables by contributing small items like odd cowrie shells. By the time they marry — when they are about twenty years of age — they start contributing larger items like *jao* or shell bands. Since girls marry almost as soon as they reach puberty, they may start immediately contributing large items. Among the Wanggulam there are a number of men who marry late. These men tend also to take part in the exchange of *jao* and shell bands. At any one time during my stay there were about 10 to 20 of these men whose ages were about 20 to 25 years. The small contributions of adolescent children and the larger ones of bachelors do not excuse the older members of the family nor vice versa.

Contributions to the *uak* are initially repaid with pork, which is consumed by the whole family. The person who actually contributes

is also the recipient of the pork. It is not eaten on the spot: the recipient takes it home where each member of the family gets part of it.

Although distributions by one spouse excuse the other, each maintains separate exchange relationships. They cannot easily keep their resources hidden from each other and often one spouse maintains or tries to maintain his or her exchange relationships using valuables received by the other spouse. Disagreement over the disposal of valuables frequently leads to fierce quarrels.

I can give only an impression of the extent to which people participate in the exchange of valuables arising from weddings. In doing so, I focus on the exchange of the large items, that is to say *jao*, shell bands and pigs, estimating the number of times people either contribute these to or receive them from a wedding payment during a given period of time. Further, I take into consideration only those payments which, firstly, were transferred during a period of 27 months lasting from 25 May 1960 (at the beginning of my first field trip) until 25 August 1962 (at the end of my second field trip) and which, secondly, were transferred on account of weddings at which either the bride, or the groom, or both, were Wanggulam. It is likely that there were distributions of *uak* for weddings at which the bride's mother had been a Wanggulam before she married, although neither the bride, nor the groom, were Wanggulam. However I do not know of any such distribution taking place during my stay. When a Wanggulam girl marries, the Wanggulam are the contributors of most of the *uak*, and so the recipients of the greater portion of the bride price (see table 4, p. 28). When the bride's mother is or was a Wanggulam, they are the recipients of most of the *uak*. Thirdly, when the groom is also a Wanggulam, they are the principal contributors to the bride price (see table 5, p. 29). Wanggulam sometimes contribute large items to or receive them from wedding payments when neither bride, nor groom, nor the bride's mother, are Wanggulam, but this seems to happen only infrequently and I do not have figures for these contributions.

The greater part of 29 *uak* were assembled by the Wanggulam during the period 25 May 1960—25 August 1962. During the same period most of 24 bride prices was assembled by Wanggulam, while they were the recipients of the greater portion of seven *uak* and of 23 bride prices. In these figures I omit a number of wedding payments assembled and distributed during one of the peaks of the religious movement (O'Brien and Ploeg 1964, p. 287).

In order to estimate the average number of times a Wanggulam

contributes to or receives from a wedding payment, I first estimate the number of Wanggulam contributors to the 29 *uak* and the 24 bride prices, and the number of Wanggulam recipients from the seven *uak* and the 23 bride prices. I adjust these estimates in order to assess the average number of times Wanggulam contributed to and received from wedding payments during the years preceding the settling of Europeans in Mbogoga in 1956. Because of the presence of Europeans in Mbogoga during the period 1960-1962, the Wanggulam then owned more valuables, and very likely transferred larger payments, than before 1956. Since I base the estimates on the larger payments transferred during the period 1960-1962, I have to adjust them to give an impression of the circulation of valuables before 1956, i.e. before the traditional system was affected by European contact.

Subsequently I total the estimated and adjusted numbers of contributors to and recipients from wedding payments during the surveyed period, and relate this figure to the number of Wanggulam men who took part in the exchange of large items during that same period.

In describing how I derive the estimates, I use the expressions 'number of contributors to wedding payments' and 'number of recipients of wedding payments', instead of the awkward phrases 'mean number of known Wanggulam contributors of large items to the above mentioned category of wedding payments transferred during the period 25 May 1960—25 August 1962' and 'mean number of known Wanggulam recipients . . . and so on'.

To estimate the number of contributors to *uak* I depend upon the nine *uak* listed in tables 4 and 7. Table 7 lists the number of Wanggulam and non-Wanggulam contributors and, in the final column, the number of contributions of unknown source. However, people told me that before 1956 they had owned considerably fewer cowrie shells than they did at the time of my field work. From 1956 the missionaries, and from 1959 the administration also, issued large numbers of shells as wages to Dani workers. I was told that before 1956 the number of shell bands per wedding payment was not more than four or five, whereas during my field work the average number was 20.5 (see table 4, bottom row). Moreover, the Wanggulam did not exchange steel implements before 1956.

The larger size of wedding payments in 1960-1962 may have been due to more people contributing than previously, or people contributed more items, or both. In order to arrive at a conservative estimate of the number of contributors prior to 1956, I assume that contributions per

	category of items	Wanggulam contributors	foreign contributors	items of un- known source
Case A	jao	28	3	3
	pig s.b. a)	12	4	3
B	jao	24	3	1
	pig s.b.	13	2	1
C	jao	12	3	
	pig s.b.	7	1	
D	jao	16	1	
	pig s.b.	6	2	
E	jao	13	1	
	pig s.b.	8		
F	jao	29	8	
	pig	1		
	s.b.	23	8	1
	st.i. b)	2	1	
G	jao	39	8	
	pig		1	
	s.b.	21	9	3
H	jao	18	9	
	pig	1	1	
	s.b.	18	4	
I	jao	19	8	
	pig	?	?	?
	s.b.	11	3	
	st.i.		1	
mean numbers of known contributors in 1960-1962	jao	22.0	4.9	
	pig	0.2	0.2	
	s.b.	13.2	3.7	
	st.i.	0.2	0.2	
assumed mean num- bers of Wanggulam contributors before 1956	jao	22.0		
	pig	0.2		
	s.b.	3.0		
	st.i.			

a) s.b. stands for 'shell band'.  
b) st.i. stands for 'steel implement'.

TABLE 7: WANGGULAM AND FOREIGN CONTRIBUTORS TO UAK

head remained constant when more goods became available. I further assume that odd cowrie shells, although comparatively scarce up to 1956, can nevertheless be classified as 'small contributions' at that time; that before 1956 the number of shell bands per *uak* was four; that one band was contributed by the father of the bride and three bands by three other Wanggulam; that these three people did not contribute *jao* or pigs as well, and, finally, that the larger number of shell bands during the period 1960-1962 enabled people to contribute to wedding payments to which they otherwise would not have contributed either a *jao* or a pig.

There are no indications that other figures, for example the number of wedding payments transferred, should be adjusted in order to estimate the number of contributors and recipients prior to 1956.

	category of items	Wanggulam contributors	foreign contributors	items of unknown source
Case F	jao	19	6	8
	s.b. a)	11	2	5
J	jao	10		7
	s.b.	6	1	
K	jao	11		9
	s.b.	7		8
L	jao	21	5	
	s.b.	4	1	
M	jao	16	1	
	s.b.	2	1	1
N	jao	10	1	
	s.b.	14	1	
mean numbers of known contributors in 1960-1962	jao	14.5	2.2	
	s.b.	7.3	0.8	
assumed mean numbers of Wanggulam contributors before 1956	jao	14.5		
	s.b.	3.0		

a) s.b. stands for 'shell band'.

TABLE 8: WANGGULAM AND FOREIGN CONTRIBUTORS TO BRIDE PRICE

The number of contributors to *uak* can be regarded as composed of, firstly, the number of contributors of *jao*, secondly, those contributors of pigs who do not contribute *jao*, and, thirdly, those contributors of shell bands contributing neither *jao* nor pigs. This categorisation of the contributors to *uak* is followed in table 7. Hence it should be noted that the numbers of contributors of pigs and shell bands mentioned in this table do not include all people who contribute pigs or shell bands, but, in the case of contributors of pigs, only those who do not contribute also *jao*, and, in the case of contributors of shell bands, only those who do not also contribute either *jao* or pigs. The same holds for the three other tables I present in the course of this section. These tables list contributors to bride price (table 8), recipients from *uak* (table 9) and recipients from bride price (table 10).

	category of items	Wanggulam recipients	foreign recipients	items received by unknown persons
Case D	jao	10		9
	s.b. a)	3		3
E	jao	13		4
	s.b.	3		2
F	jao	26	3	
	s.b.	11	4	1
	st.i. b)		1	
I	jao	23	2	1
	s.b.	5		
	st.i.			2
mean numbers of known recipients	jao	18.0	1.3	
	s.b.	5.5	1.0	
	st.i.		0.3	
assumed mean numbers of Wang- gulam recipients before 1956	jao	18.0		
	s.b.	3.0		

a) s.b. stands for 'shell band'.

b) st.i. stands for 'steel implement'.

TABLE 9: WANGGULAM AND FOREIGN RECIPIENTS OF *UAK*

	category of items	Wanggulam recipients	foreign recipients	items received by unknown persons
Case C	jao	12	3	2
	pig	1		
	s.b. a)	1		3
J	jao	10		3
	pig	1	1	
	s.b.	6	1	1
L	jao	19	4	
	s.b.	3	1	
O	jao	16	10	
	s.b.	10	2	
P	jao	20	2	4
	s.b.	12	9	?
	st.i. b)	1		1
mean numbers of known recipients	jao	15.4	3.8	
	pig	6.4	2.6	
	s.b.	0.4	0.2	
	st.i.	0.2		
assumed mean numbers of Wanggulam recipients before 1956	jao	15.4		
	pig	0.4		
	s.b.	3.0		

a) s.b. stands for 'shell band'.

b) st.i. stands for 'steel implement'.

TABLE 10: WANGGULAM AND FOREIGN RECIPIENTS OF BRIDE PRICE

The penultimate row of table 7 shows the mean number of contributors to the nine listed *uak*. I assume that these figures are representative for the number of contributors to *uak* transferred during the period 25 May 1960—25 August 1962. The last row shows the adjusted figures which I assume to be representative for the number of contributors to *uak* prior to 1956. Hence I estimate that prior to 1956 the mean number of Wanggulam contributors to *uak* was  $22.0 + 0.2 + 3.0 = 25.2$ .

In the same way I estimate the mean number at that time of Wanggulam contributors to bride prices, of Wanggulam recipients from *uak* and of Wanggulam recipients from bride prices.

Table 8 shows that this figure for contributors to bride prices is  $14.5 + 3.0 = 17.5$ . Table 9 shows that the figure for recipients from *uak* is  $18.0 + 3.0 = 21.0$ . Finally, table 10 shows that the figure for recipients from bride price is  $14.5 + 0.4 + 3.0 = 18.8$ .

I mentioned above that I estimate the frequency with which Wanggulam contribute to and receive from wedding payments, taking into account only those payments for which they were the principal contributors and recipients. I mentioned too the numbers of these payments during the period 25 May 1960—25 August 1962. I assume that the same numbers of payments took place in the course of 27 months prior to 1956. The estimated amount of Wanggulam contributors and recipients to these payments is  $29 \times 25.2 + 24 \times 17.5 + 7 \times 21.0 + 23 \times 18.8 = 1730.2$ . Since about 115 Wanggulam men participated in the exchange of *jao*, shell bands and pigs, the mean number of times each of them took part, either in person or through his spouse, in the exchange of these valuables is  $1730.2 : 115 = 15.0$ .

It should be noted that the circulation of *jao*, shell bands and pigs is more intensive than the above figures imply. Firstly, the estimates used in the above calculations are on the low side. Secondly, Wanggulam probably are contributors to and recipients from a number of other wedding payments, so that the actual number of times Wanggulam take part in the transfer of valuables, occasions which give rise to the transfer of *jao*, shell bands and pigs is greater. During my stay 21 cremations took place among the Wanggulam so that as many cremation payments were assembled and distributed. However, these payments are smaller than wedding payments. I was further told that payments compensating killings, which were not transferred at all during my stay, were much larger than wedding payments. As far as I know they occurred less often: I got to know about 24 intra-parish and 6 inter-parish transfers of blood money during the period from about 1935 until 1960. As I was not able to get exact data on the size of the payments, I do not know the extent to which they intensified the circulation of valuables.

Finally, I should mention that often people contribute to both *uak* and bride price assembled for the same wedding, or that they contribute to the bride price and also receive from the *uak*. At one wedding

between a Wanggulam bride and a Wanggulam groom, which occurred during my stay (table 3, case F), 54 Wanggulam contributed large items to the *uak* and at least 28 contributed similar items to the bride price. Four of these 28 had contributed to the *uak*. Since the bride's mother belonged to the same section as the groom, the greater part of the *uak* was distributed to members of the section which had contributed a large part of the bride price. There were 37 Wanggulam recipients of large items from the *uak* and 21 of these had already contributed to either the *uak* or the bride price. The large overlap is however probably due to the increased number of cowrie shells which the Wanggulam could dispose of at the time of the wedding.

## CHAPTER 4

### SUPERNATURAL POWERS

In the beginning of 1960 the Mbogoga Dani responded *en masse* to evangelization and from then on they asserted they were Christians. Their attitude towards their traditional religion changed accordingly: they began to condemn strongly their former religious ideas and practices. They abandoned all ceremonies and burned all objects associated with their traditional religion. I never witnessed any of the ceremonies, nor did I see any of the objects. Much of the account of traditional beliefs which follows is therefore based solely on oral information given to me by the Wanggulam.

In the present chapter I discuss:

- I a number of supernatural beings;
- II forms of injurious magic;
- III the changes in the traditional beliefs since 1960.

#### I

The former religion of the Wanggulam postulates the existence of a large number of supernatural beings. The people use the term *kugi* to refer to them all. I will use the term 'spirit'. The Wanggulam do not have a clear image of these beings. They cannot say what most spirits look like. They know that one of them has long ears, makes piercing sounds, and is capable of shooting dwarf arrows, the people do not know how. Also they do not try to enter into the spirits' feelings: they do not know how the spirits feel about themselves and about other spirits, and about human beings. The three types of spirits whose actions, Wanggulam feel, influence them most deeply, are:

1. the ancestral spirits, the *anggena*;
2. a class of spirits called *monggat*;
3. a number of other spirits, each of whom is responsible for one particular type of misfortune.

Before starting the discussion of these three types of spirit I should mention that, although the Wanggulam discontinued the ceremonies associated with the spirits in the beginning of 1960, they still believed in their existence in the middle of 1962. I will come back to this point.

### 1. *Ancestral spirits.*

Wanggulam believe that ancestral spirits — in particular the spirits of their agnatic ancestors — influence their lives deeply, because the support of these spirits is believed to be essential for support in war, and thus essential for raising a man's status. The influential men in Wanggulam society, the big men, owe their prominence to their fighting and especially their killing ability. A man tries to win his ancestors' support by performing a rite, *amulok kunik*. I can offer only a tentative translation of this name: *amulok* means 'reflection' or 'imprint'. People refer to their reflection in still water as their *amulok*, and they hold that a man leaves his *amulok*, his imprint, for example at the place where he usually squats down. *Kunik* is a form of the verb 'to relate', or 'to bring in relation with'. The whole term *amulok kunik* might mean 'together with the reflection (of one's ancestor)'. The performance of the rite takes place before or during battle: the man puts down an arrow with the head pointing towards the enemy. The arrow may be one handed down by the father of the performer of the rite, as being the arrow with which one of his ancestors had been shot, but this is not always so: he may also use a new arrow.

The ritual arrow is not used in the battle. Squatting down at the tail end of the arrow the performer concentrates his thoughts on the man or people he wants to kill, and doing this he says: '*waro, waro*', 'kill, kill'. He does not utter the name or names of the prospective victims. People say that it is none of the bystanders' business to be told the identity of the enemies a warrior is going to fight. There may be close relatives of the intended victims among the bystanders who might warn their kinsmen if the names of the victims were uttered and overheard. Other arrows are put down parallel to the ritual arrow and with their tips somewhat behind its. These arrows are used in the ensuing fight. All men know how to perform this rite, but it is believed that only a few are successful in securing their ancestors' support. Ancestors support only brave descendants, so that bravery is essential to secure support and support essential to be brave.

Favourable to the dominance of the big men is the idea that their

ancestors support not only their brave descendants, but also the latter's fellow combatants. Big men, renowned for their bravery, are asked to, or offer to, lead a war party and/or perform *amulok kunik*. They themselves do not always join in the fighting. The arrows consecrated during the ceremonies were handed out to the combatants. The success of a war party is attributed to the support given it by a big man, whose prestige is accordingly enhanced.

Wanggulam say that a man has difficulty in establishing himself as a big man if his elder brother has already acquired a reputation as a fighter. As brothers often fight in the same cause, the success of the younger may be interpreted as the result of the elder's good relationships with their common ancestors. Without ancestral support people are likely not only to be incapable of killing others, but also to be killed themselves. Men often use different ancestors to support them against different adversaries. The names of the ancestors being used should remain secret: if other people know their identity the spirits lose — according to some informants — their power to support, or — according to others — they get angry with their descendant and allow him to be killed. These beliefs made it very difficult for me to collect genealogies. For a long time people were not prepared at all to tell me the names of their ancestors; later they told me, whispering the names and trying to prevent others from hearing. Some people said that but for the religious movement and the conversion they would not have been prepared to tell me. From the way people spoke of their ancestors I got the impression that these were more important in their role as supporters in fights than providing a genealogical charter for a segmented kinship group. Men were often not sure about the exact kinship relations between those ancestors whose names they knew. People giving joint testimony often did not agree. In some cases they were not sure whether a name belonged to a male or a female. The men of the Penggu sub-sections mostly draw their support from the common pools of ancestors. In Karoba I, a large sub-section without further sub-divisions, the groups of men using ancestors in common are often very small and sometimes comprise merely full brothers or first cousins.

Ancestral spirits, *anggena*, can be transferred from one man, or a group of agnates, to another man, or another group. This transfer occurs only between real or classificatory kin, but not necessarily close kin. For example, it is sufficient if the transferrer belongs to the ally of the transferee, or to the *anembeno* of the transferee but to another

section. The transfer does not require an elaborate ceremony: the ceremonial arrows are simply handed over. The transferee steams a pig and tells the arrows: 'You are with me now, and no longer with them'.

The *anggena* not only provide support in fights, they also force people to fight, for they do not tolerate the death of one of their descendants unless it is paid for. The kin of the dead man must obtain compensation or kill in retaliation, or else lose the support of their ancestral spirits. All deaths are attributed to overt or secret violence and must be avenged, hence a death often leads to troubles.

After men have successfully killed in retaliation, they notify their *anggena* by joining two sticks and putting these into a small bag hung on the wall of the men's house. This happens during a nocturnal ceremony. At least one pig should be killed. The tails of the slaughtered pigs are fixed to the bag. Ideally five pigs should be killed, but the pigs available are often insufficient to meet this requirement (see p. 11). Wanggulam do not have a clear idea of the relation of the bag to the spirit, but say that the bag is not the house of the spirit. They know they can communicate with their *anggena* through the bag. The spirit of a person who has been killed is presumed to join his ancestors, and to support the living members of his section in their efforts to revenge his death. After a killing, therefore, the killers try to prevent the dead man's spirit from joining his ancestors. This involves a ceremony with dancing, again during the night, the climax of which seems to have been the enclosing of the spirit in a gourd.

These ceremonies are performed by men only, and carried out in great secrecy. Women and children are not allowed to witness them and — according to men — they do not even know when they are actually performed, as the ceremonies take place during the night in and around the men's house, or on a dancing ground outside the hamlets. Women are not allowed to see the bags hung on the wall of the men's houses, and are therefore normally not allowed to enter these houses. After a man has died the women have to wail over him. On these occasions they enter the men's house, but the bags have always been removed beforehand and taken to another men's house. Wanggulam say that the ceremonies are ineffective if women witness them, but they cannot provide further reasons.

The influence of the *anggena* is not restricted to warfare. Other ceremonies consecrated to these spirits serve to increase the number of pigs, and to obtain success in marriage arrangements. Finally, in a case of serious illness one should notify the *anggena* who then bring

about a speedy recovery. Wanggulam say they do not know how the spirits do this.

## 2. *Monggat spirits.*

*Monggat* is a generic name. As with the *anggena*, small groups of men have their own, specifically named, *monggat*. People having a group of *monggat* in common may have different ancestral spirits.

*Monggat* are known to have long ears and to be capable of killing human beings. Although normally people say that deaths are to be attributed either to warfare or to the murderous practices of women (to be discussed in section II of this chapter), they sometimes seem to be uncertain whether a *monggat* — ‘or yet another spirit perhaps?’ — can have had a hand in it. It can also bring about minor physical disabilities like toothache.

People do not know precisely how a *monggat* kills. Some say it is able to kill by means of small arrows. Others say it prompts women to work injurious magic. A *monggat* is believed to induce people to misbehave in other ways, for it whispers in people’s ears inciting them to steal or to commit adultery.

*Monggat* are not disturbers of human affairs in all their activities. In several situations, e.g. during a person’s illness or when war threatens, ceremonies dedicated to the *monggat* are performed. These involve pig-steaming and take place in daytime, with women and children participating. During the ceremony the *monggat* is called to indicate whether the sick person will die, or whether the war will take place, as the case may be. If there has been a killing in an intra-parish conflict and the killer does not pay compensation, a *monggat* is likely to cause too much rain to fall. In order to prevent still more rain the parties are said to become reconciled.

## 3. *Specialist spirits.*

People know what the spirits of this group are capable of. There are many of these spirits and each is capable of inflicting some special misfortune upon humans, e.g. one of them can bring diseases to thieves, another can cause landslides, yet another, *lembo*, can kill people by getting hold of the remnants of his food or the waste of his body.

These spirits can be controlled to a certain extent, for there are people who know how to prevent a spirit from inflicting a misfortune. These

people too are specialists, as each of them knows how to control only one of the spirits. With one spirit, *lembo*, the specialists are women, while with the other spirits they are men. Usually there is more than one person who knows about a particular spirit, but the groups of specialists are always small in number. Men mostly transmit their knowledge to their sons, women to their daughters. The ceremonies through which the spirits are controlled all have certain features in common. They involve the killing of a pig and the erection of a forked pole. In the fork is placed a bundle with grasses, leaves and sometimes other objects. The composition of the bundle differs with the particular spirit involved. *Lembo* again is controlled in a different way. The woman specialist scours a large area in a frantic rush trying to catch *lembo* and to take from it the things it has got hold of. The specialists receive no remuneration other than a piece of the pork steamed during the ceremony.

The misfortunes controlled by the specialists are serious, yet there are no indications that people were anxious to secure the friendship of these specialists to ensure their cooperation in treating spirits. Spirits of this type are not all evilly disposed towards human beings: one of them comes to the support of people by bringing misfortunes upon thieves. On the whole people have no more than a vague idea how spirits manage to interfere in human affairs. With *monggat* they say that it prompts them. They confess ignorance as to the way in which *anggena* support their descendants, or how *lembo* harms people after it has got hold of their excrement. Nor are they sure, for example, when a person falls ill, whether the disease should be attributed to a spirit at all, and, if so, to which spirit. People are not sure about the range of courses of action several spirits are capable of, and in most cases they do not know why a spirit feels inclined to interfere in human affairs.

With all spirits it is important to know their names. Laymen know the generic name, but only the specialist, or the descendant of an ancestral spirit, knows the call name of the spirit. As with the ancestral spirits, people think that the success of the ceremony is endangered when other people know the call name of the spirit involved, so that they were very secretive about them.

People know that in other parts of Mbogoga and outside the valley ceremonies are performed which they themselves do not know about. These ceremonies may be consecrated to other spirits. Some of the ceremonies performed by the Wanggulam themselves have been recently introduced

from neighbouring areas. In my view this indicates that people believe that their own knowledge of how supernatural beings influence human lives and how they may be controlled is incomplete and partly incorrect. In the other parts of this chapter other indications of this attitude will be discussed.

Because of the conversion of the Wanggulam to Christianity, it was not easy for me to determine whether the traditional beliefs in supernatural powers were an important element in Wanggulam every day life. The accounts of the ceremonies make it clear that people enjoyed performing them; possibly, therefore the ceremonies may have been highlights in their lives. It seems that they took special delight in the dances, and the men liked re-living the secrecy surrounding the ceremonies dedicated to the ancestral spirits.

The conversion was not accompanied by a renunciation of the spirits and their powers. Wanggulam interpret the missionaries' teachings as saying that the spirits are bad and accordingly they still believe in the existence of spirits. It is thought that the spirits have retreated to the uninhabited forest, but people still attribute adverse events to their activities.

## II

Beliefs in injurious magic and other secretive harmful practices still play a very important role in the lives of the Wanggulam. *Mum*, the injurious activities of women, preoccupies people far more than the magic practised by men; all women are believed to possess special abilities to kill, and all people, men more than women, are afraid that they may succumb to the activities of women. Every death arouses suspicions that *mum* has been worked. Like beliefs in the existence of spirits, beliefs in *mum* and other harmful magical practices have survived the conversion to Christianity. Here too the missionaries' teachings are interpreted as condemning these practices and not as denying their efficacy.

Men do not know how women kill, nor do they know how to counter their murderous practices. They are not sure whether women use supernatural means. Often they say that women still have a fiery substance in their possession which, they assert, emerged from a hole in the ground on the west slope of the Luaga a long time ago. They think that women kill by putting this substance into a person's ear. About its further properties men are ignorant. Sometimes men say that women

kill by fixing their eyes upon their victim, so that men tend to refrain from going to large gatherings, and shun contacts with women who might have a grudge against them.

Men know a number of methods of harming others, but people give less thought to these than to *mum*. The cases in which men worked injurious magic and about which I came to know are far less in number than the *mum* cases. In the course of the latter, 37 persons were killed, in the course of the former twelve, with only two cases accounting for nine of these twelve victims. Neither men, women, nor children are safe from *mum*, but adult male victims are in the majority: among the 37 casualties there are 25 men, five women, and seven children. People believe that women are inclined to work *mum* on the slightest provocation, e.g. in annoyance over the theft of a few sweet potatoes, but in the 37 cases, former killings were the motive in 16 cases, thefts of pigs or *jao* in seven cases, and default in payment in six cases. I have no data concerning motive in five cases, but only in one known case the motive was a trifle: a woman worked *mum* against a man because he had refused to give her a bunch of bananas. The victims may be close relatives to the killer: in two cases a woman killed her husband, and in other cases she killed her husband's brother and her sister's child.

Men deplore that women know about *mum*, while most women I asked, denied knowing about it, saying that it was practised by others. People dislike the insecurity with which *mum* surrounds their lives. In itself *mum* is not regarded as bad: women are often asked to kill people from other parishes. With intra-parish killings action against the presumed sorceress is not taken by the whole of the parish, but by the people closest to the victim. Compensation is paid by the closest kin of the killer (both by the group of her husband and by the group of her brothers). Only one woman told me how she had killed. When she saw a man from a neighbouring parish pass through Wanggulam territory she followed him with her eyes concentrating her thoughts on two *lembo* spirits. The man had died shortly afterwards. The conversion to Christianity led to a number of burnings of objects with magical and religious significance. It is reported that some women brought to the burning objects they used to work *mum* with, so that it seems that there are other techniques.

It is clear that *mum* is indeed practiced, but my information does not suffice to say whether it is practiced as much as many people think.

Men see *mum* as the counterpart of their weapons like spears and bows and arrows. They say that men kill with the latter type weapons, and that women kill with *mum*. A short myth states how women formerly had the weapons the men have now. The men took them after it had been seen that the women were no good at handling them. Some men said that after this incident women had turned to *mum* to make up for their loss.

To find out whether *mum* has been used and which woman has used it the Wanggulam have a number of techniques at their disposal. The most commonly used technique is to steam grasses: an earth oven is filled in the usual way but without food. The steamed grass leaves are strewn around. If they are crumpled and of a darkish colour, *mum* has been at work. If they are straight and light, *mum* has not been used. A man steams grasses on more than one day, and during the later steamings he concentrates his thoughts on a woman he suspects. Whether she has used her power or not is again indicated by the colour and the shape of the steamed grasses.

The steaming is often accompanied by efforts to shoot birds or wild pigs. If a man manages to shoot them, this indicates that *mum* has been at work. These methods do not provide conclusive evidence however. In order to get to the truth the enquirer should cut a slit in the ear of the indicated woman. If the ear bleeds she has killed, if not, she is innocent. Although the outcome of this test was always mentioned as final evidence, the accuser sometimes made the woman confess by torturing her, hanging her by the hands from a pole.

In the next case yet another technique will be mentioned. I would argue that there are so many steps and ways to identify the killer, because people consider that their methods of diagnosis may be incorrect, just as they consider that their ideas about supernatural beings are incomplete or incorrect.

#### CASE 1, TILUBAGATLAK KILLS NGERENGGALIGWE'S SON

When Ngerenggaligwe's son, Ajumatnarak, became seriously ill, she and her husband Perenatmendek, a Wabit man, decided to kill a pig, dedicating it to the ancestral spirits so that the boy's health might be restored. They killed and steamed a pig allocated to Perenatmendek's other wife, Tilubagatlak. The latter was absent and did not know about it until she came back to the hamlet. She became very angry when she found out.

Ajumatnarak did not recover; he died, and his father became suspicious that Tilubagatlak had worked *mum* against his son. To find out, his brother Nginarek went on a pig hunt. Perenatmendek himself

*All the people mentioned in the genealogy live in four hamlets. None of the hamlets is more than 15 minutes' walk from any of the other three.*

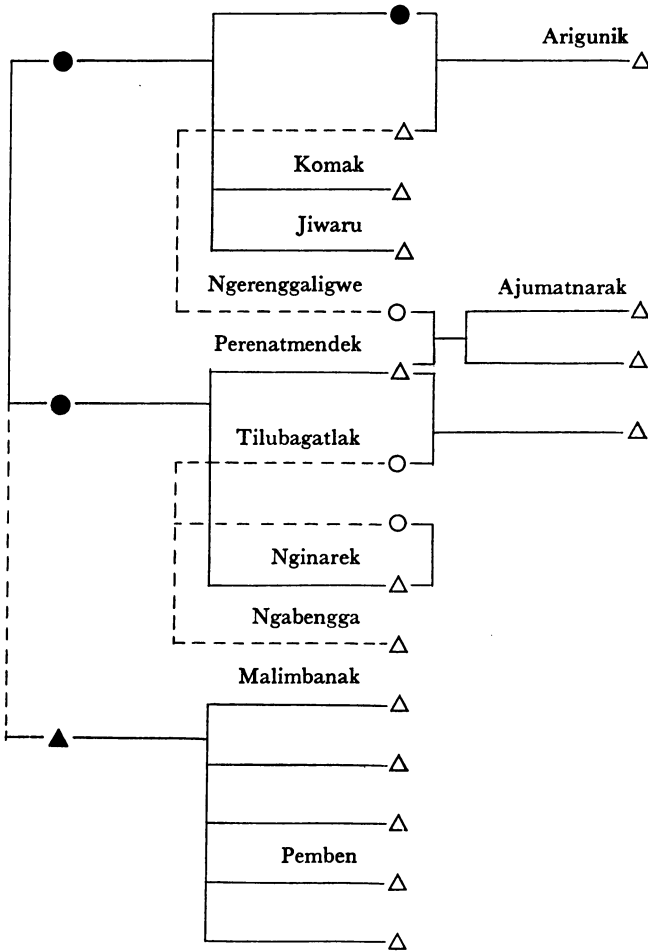

FIGURE 4: PERENATMENDEK'S CLOSEST RELATIVES

did not go, because it concerned his wife. Nginarek managed to kill two wild pigs. In order to get more certainty, Nginarek and Pembén, his MKBS, steamed the pigs. While Pembén was preparing the oven, Nginarek looked on from a distance. If he would see that Pembén was assisted by a woman this would be a strong indication that *mum* had killed Ajumatnarak. In fact, Nginarek saw that Pembén was not alone, but was helped by Tilubagatlak. Finally her ear was cut and it bled. Although Perenatmendek was very angry with her and gave her a thorough beating, he did not see reason to repudiate her. Instead he

assembled a compensation payment. The main contributors to this payment were his brother Nginarek, his MKBS Malimbanak with whom he lived in one hamlet, Ngabengga, Tilubagatlak's KB, Komak, his MZS, and Arigunik, his MZDS. The payment was transferred to Ngerenggaligwe's brothers and classificatory brothers, and Arigunik received part of it as an agnatic relative of Ngerenggaligwe. Except for Arigunik and his father, the members of her *anembeno* lived outside Wanggulam. Until then both co-wives had been living in the same women's house, but after her son had been killed Ngerenggaligwe moved to another hamlet and went to live with the wife of Nginarek who lived together with his MZS, Komak.

The most discussed magic practised by men is *pulinggwe*, cursing a sister's daughter, or a child or a daughter's child of a female member of the men's own *anembeno*. It is practised when a man feels he has not received his due at the distribution of an *uak*. Suppose a man has contributed two *jao* to the *uak* for his sister and that at the distribution of the *uak* for his sister's daughter he receives only one *jao*. He is then likely first to ask for another *jao*; if this stone is not given to him, he may curse his sister's daughter to make her barren. As with *mum*, a number of techniques may be used: uprooting or burning a tree, brushing of the hearth poles with ashes, and disturbing the grave of one's father. While a man does this, he says repeatedly: 'She should become barren', or he simply concentrates his mind on this sentence.

The outcome may be that the girl does become barren, but there is also the possibility that her children will die during infancy. I heard about a number of these curses. In one case the fact that a child was stillborn was attributed to a curse, in another case its early death.

With this retaliation the counteraction is to some extent weighed against the default. A girl's mother's brother takes action because he has not received what he is due from her *uak*. This is the fault of the distributors of the payment, the fathers and brothers of the girl. Through his action a MB brings about the barrenness of his ZD: she will not bear children. As there will be no children, there will not be any chance of an *uak* in the next generation. The brothers of the girl will suffer the same disadvantages as their MB did: they also will not receive what they contributed to the *uak* of the girl, their sister. In its side-effects the retaliation outdoes the initial offence: the husband of the girl will remain childless and the curse might cause the bad health or the premature death of his children.

Another magical practice was called *aga polenggwe*, that is to say 'to split the tail'. This was used when a man either did not contribute

to a compensation payment, or asked for payment without being entitled to it. In an actual incident I heard about, it was used in quarrels concerning compensation for a killing. In either case the collector of the payment split the tail of one of the pigs he had killed for the payment. While splitting the tail he concentrated his thoughts on the neglectful contributor or the unjustified claimant. The tail was attached to a bag (see p. 49) and hung on the wall of the men's house, so that the ancestral spirits would get to know about the cases and bring about the death of the defaulter. Wanggulam do not know how the spirits cause the deaths. I heard about three cases in which this method was used. One is mentioned in case 19 (see pp. 154 ff.), another was directed against a negligent contributor and was said to cause six deaths within a short period of time. The last four of these deaths occurred during my stay. Figure 5 shows the closest agnatic relatives of the man concerned, Agalai. The numbers show the death order.

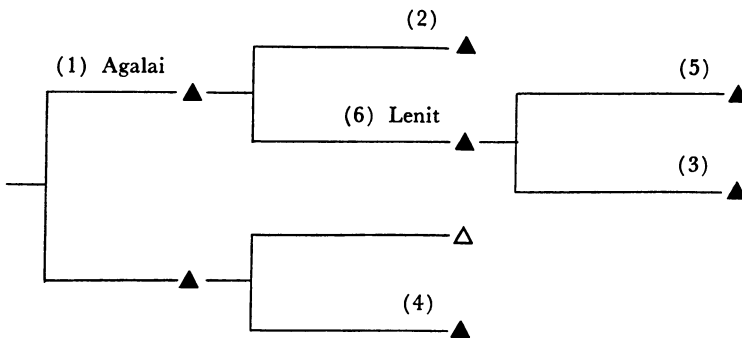

FIGURE 5: CLOSEST AGNATIC RELATIVES OF AGALAI

In the third case so far only one woman has died.

With this method too, retaliation is weighed against the default. By splitting the tail one inflicts upon the defaulter the situation in which his behaviour would have been correct. The argumentation of the collector of the payment can be summed up as: 'If you act towards me as if you have suffered a loss, and so are entitled to a payment, or are entitled not to contribute, I will act towards you in such a way that in fact you will suffer this loss'. In practise the retaliation might outweigh the initial offence: in Agalai's case six people died after Agalai had refused to contribute to a payment compensating the killing of one man.

A Wanggulam may also seek to harm another person supernaturally by wilful destruction of his own property. It is believed that after the theft of, for example, a stock of bananas the wronged man can bring about the death of the thief by destroying a number of his own banana trees. People said that the destruction of a man's own property was very unusual. In the only case I heard about the method was said to have been successful.

### III

Important changes in the traditional beliefs took place in 1960 and the following years. In the beginning of 1960 a group of Dani from the Ilaga valley travelled for several months through the central parts of the Highlands in order to preach the gospel and to convert people to Christianity (Hitt; 1962, pp. 216 ff.). Originally they were led by an Ilaga Dani, later by the European missionary at Ilaga.

These crusades led to a number of burnings of objects with magical and religious significance throughout a large part of the Central Highlands. At Mbogondini a burning took place in early March. At about the same time the government intervened in what became the last large scale war in Mbogoga before the pacification by the Dutch administration. In the period immediately preceding and following the burning a number of rumours went around: there would be a shower of steel axes; everybody would have to follow 'the straight way', which was taken both in its metaphorical and its literal sense, and so would have to break through fences and to traverse gardens; and nobody would die any more. By the time of my arrival in the field in the middle of May these rumours had died down, but the religious upheaval had not. Many people attended the Sunday meetings organised by the missionaries, they kept Sunday as a day of rest, prayed before meals, and sometimes tried to memorise bible stories. The former way of life, exemplified by frequent stealing and fighting, was strongly condemned. Later the Mbogoga Dani used to say that — thanks to the conversion — stealing had decreased a great deal, while fighting had ceased altogether. People maintained that clothes like penis gourds and head dresses, and ornaments like armbands and necklaces, were 'bad' and had to be done away with, but in actual fact continued to wear them.

Nobody declared himself openly against the movement. It was recognised that a few people did not participate, but almost everybody said he was a Christian and a large majority of the people went regu-

larly to the Sunday meetings. The movement did not disturb the economic life of the people to any extent. The season for the making of swiddens started as usual in the middle of June (three months after the burning) and took its normal course.

It was not easy to let the Dani explain what they were attempting to attain by behaving in this way, not only because they were reluctant to be frank with me (see p. 5), but also because they themselves did not have clear ideas about what was going to happen. They said they expected to get European clothes and implements, above all steel axes and bush knives. Whether this was the only thing they expected to get was not clear. Nobody seemed to have more than a vague idea how they would get things like clothing and axes. When asked about this, people mostly said: 'We will get them from you, white people'. But nobody asked me when and how it would happen. People did not any longer expect a sudden abundance of goods. The rumours circulating in the beginning of 1960 about an impending shower of axes had not influenced the eagerness of the Dani to work for 40 days to earn an axe. The missionaries themselves were sceptical about the conversions. They did not believe there was a single Dani who as yet had grasped the essence of the Christian faith, not even among the group of pupils they had brought together.

The movement went on during the whole of 1960. In December another burning took place, this time mainly of weapons. During the preceding week people had announced that they would take this step. There were rumours that there had been burnings elsewhere. As people talked about it in the same way as they did about doing away with other 'bad' things they still retained, it seemed doubtful to me whether anything would happen. The next Sunday the missionary gave a speech urging the people to burn their weapons. According to the Dani he said that if they did not burn their weapons they would not become Christians. The next day the burning took place. While the Wanggulam men were gathering to go to the mission station they were very uncertain as to whether all Wanggulam men would join them. They were relieved to see that almost everyone did come. On their way to the station, the Wanggulam paused several times to make sure they were not the only group going there. Again their doubts were refuted when all other Mbogoga parishes, led by their big men, appeared. At the mission station where the burning was to take place, the missionary addressed the men and said that one should not burn one's weapons out of a whim, but because one felt that Christians could not live with them.

The Dani assumed they had the proper Christian attitude. Heedless of the missionary's further counsel, they talked among themselves. Groups represented by their big men accused each other of keeping weapons back with treacherous intentions. For a while it looked as if the burning would not take place. The impasse was broken by the Wanggulam who rushed off, led by their biggest man, Wandin (see Case 2, pp. 78 ff.) and put their weapons on a large heap. The other groups followed, slowly, one after the other. The next day normal life was resumed; it seemed as if nothing had happened. Religious zeal slowly declined. There were less discussions about the missionaries and what they had said, and less people went to the Sunday meetings.

This burning was the last occasion in the movement on which the big men took the lead. Later they faded into the background, and leadership in the community was taken over by the mission pupils. This was accompanied by changes in the composition of the groups of pupils. Originally the missionaries had included a number of big men among the pupils they had brought together to live in a newly built hamlet close to the mission station. These pupils were all Mbogoga Dani and they represented all Mbogoga parishes. It seems that the big men were difficult to indoctrinate and several returned to their former hamlets; others, it is true, stayed with the pupils but were not active in preaching and leading meetings. These functions were performed mainly by younger pupils, men of about 20-30 years, who were too young to have been 'big men' in the traditional sense.

The lull in the movement persisted throughout 1961, with the next flare-up occurring in mid-1962. It started with a large feast on June 7, a few days before Pentecost, organised by mission pupils, in gratitude because — as they put it — 'Jesus had entered their hearts'. Feasts of this kind occur several times a year, but unlike the others, this one triggered off events of the greatest significance for the Dani. The missionaries had emphasised the celebration of Pentecost. This is probably one of the reasons why this particular meeting became the starting point of the revival. Another reason is that the missionaries' knowledge of the Dani language had increased considerably, especially during the last months, so that they could better indoctrinate their pupils. During the week following Pentecost, June 10-17, the mission pupils went out to preach. They held long speeches saying they pitied their fellow Dani as they had not really opened their hearts to Christ, but had only feigned to do so. The speeches, sometimes accompanied by crying, made a deep impression. People gathered almost every day

during the next week to listen to the teachings of the mission pupils, to pray, and to sing. For some time a crying fit was considered to be the sign of conversion. Many people went through these fits, though they were gradually forgotten and after a few weeks no longer occurred. At the same time the mission pupils taught that it was essential to learn bible stories. Consequently people spent much time in almost frantic efforts to memorise these stories. It was also suggested that *jao* stones were bad and should be discarded. People had been saying before that they would throw away the stones, but their delight in them and the value given to them had never declined. During the week of June 17-23, people started hurriedly to settle outstanding debts involving *jao*. This action indicates also that people still felt obliged to make the wedding and cremation payments involved in the debts. In the second half of the week groups of men went to the mission station to throw their *jao* into a pit. On Saturday June 23 the men from Karoba and Mabu sections went there. The missionary and his pupils tried in vain to prevent the men from throwing away their *jao*, impressing upon the men that they should really be sure before destroying their traditional objects of value. The men said they were sure and insisted that the stones were bad because they had been a source of quarrels in the past. Some people said they would do away with their pigs and pandanus, allegedly because they too had formerly caused conflicts, but this idea was never carried out. The Dani seemed to contemplate throwing away all non-European items. Pigs were retained because it was realised that the missionaries ate native pork. There was no talk of abandoning cowrie shells, but people began to prefer those given out by mission and government while the pre-contact shells decreased in value. There was a very conscious imitation of European customs. People bathed, and men stopped greasing their long hair and tried to cut it. During the daily gatherings and Sunday meetings men and women did not sit in two separate groups according to the Dani habit, but husband and wife sat next to each other as they had seen Europeans do during a mission conference. As the people realised that Europeans had difficulties in understanding Dani kinship terminology, its usage was also considered to be non-European and people started to greet each other with *ore*, regardless of relative age, sex, and *anembeno* affiliation, although until then this term had only been used between people of the same age and sex and mostly of the same *anembeno*.

It became clear that the conscious goal of the movement had

changed. The idea of material rewards, which had been very strong in 1960, was overshadowed by expectations of an 'eternal life' which was interpreted as a very long life on earth. Longevity also was thought to be an attribute of European life. Expectations of this kind had already surged up in 1960, but they had soon died down. These beliefs were supported by elements from the indigenous mythology. A legend apparently common to a number of Dani groups (Larson: 1962, p. 56) relates how man forfeited eternal life. Long ago a snake and a bird had a race. If the snake had won, man would have become like the snake and would have enjoyed a never-ending existence. When the missionaries began preaching their message of eternal life, the Dani equated it with the old story of the snake. The Wanggulam had other facts on which to base their expectations of longevity; during my stay in 1960 remarkably few people died, mostly young children or old women. No death occurred of people between age 10 to about 50. The Wanggulam noticed this and attributed it to my presence, combined with their favourable attitude towards Christianity.

On July 15 a number of Wanggulam, both men and women, and including some influential members of society, gathered on their way back from a Sunday meeting and decided to do away with the in-law avoidances by which a man was not allowed to utter the names of his wife's parents and vice versa. A number of men said: 'We do not use kinship terms any more and call everybody *ore*. But in our hearts we still use the terms. We should show that we have done away with them and from now on utter the names of our in-laws'. This was restated by several people and there was no debate. The main result of the discussion seemed to be that people assured that they were all agreed on the change. Then they started to talk with in-laws, if present, in order to utter their names.

About the same time people started to say that they had done away with wedding payments altogether. After the *jao* had been thrown away, one marriage took place. The *uak* consisted of the usual items except for *jao*. The mission pupils said that from then on brides would be paid for by the blood of Christ. This was probably a reinterpretation of the Christian dogma that humanity — as the missionaries put it in Dani — has been 'bought' from its sins by the blood of Christ. It was the last development before I left the field, and it was too early to say whether the decision was effective.

The movement shows how the Dani think about their own traditional

culture. The aim of the movement was to attain the European way of life. In its initial stages this way of life was exemplified by the wealth the new arrivals displayed; in its later stages by their supposed longevity. At that time the craving for wealth still existed, but it was overshadowed by the desire for a long life. It could be overshadowed, because western goods had begun to be imported, and people were confident that more would come. In the Swart Valley a similar movement spread, but there the material aspect was more emphasised, presumably because less western goods had been imported (O'Brien; 1963).

The Mbogoga Dani had difficulties in conceiving that there might be any Europeans who were not Christians. They equated becoming a Christian with becoming a European, and in response to the mission teachings that violence and the traditional religious ceremonies were incompatible with Christianity, they regarded their former culture as an impediment to attaining greater welfare. Merely to admire the European way of life was to admit that their own way of life was inferior. It is significant that the Dani did away with all things which seemed alien to the European way of life, such as *jao*, old cowrie shells, spears, bows and arrows, and kinship terms while retaining those items they believed to belong to it, such as pigs and new shells. They were all the more inclined to set their hopes on Christianity because they were discontented with the achievements of their traditional culture. The Dani felt that their former rites had failed to ensure healthy pigs and large crops. Due to the introduction of steel implements the size of gardens, and consequently of crops, had increased. People asserted that the number of pigs had also increased. The Dani were glad that fighting had come to an end and the chain of revenges and counter-revenges had been interrupted, and that men and women were in little danger of being ambushed.

During the discussion of the traditional supernatural beings and the methods to control them, and also during the discussion of *mum*, I argued that Dani feel that their notions about supernatural phenomena are incomplete and may be incorrect. This supposition is in line with the readiness with which the people went over to the Christian faith, since a recognition of the possibility that the missionaries knew about supernatural powers of which the people themselves were ignorant is likely to have facilitated conversion.

People were not yet thoroughly convinced that Christianity would serve their purpose better than their former religion and that their conversion would bring them the welfare the Europeans enjoyed and

which their former culture had lacked. Few men actually told me about their doubt, evidently because the majority were afraid that I would disapprove of it. There were other indications: the baby of one of the most ardent Christians among the Wanggulam died. One man received the news with a chuckle and merely said: 'And I thought people would not die any more so young'. He did not seem greatly disappointed.

People were not yet at ease in adopting the European way of life. Although new axes were frequently received as wages, people were still anxious to see and to touch them. They always inspired the people with awe. Many men owned clothes, but few actually wore them. Even those who did seemed still afraid of their clothing: a few men actually abandoned them after having been ill. Notwithstanding the drastic developments in the movement during 1960 leading to the abandonment of ceremonies and to the burnings, in June 1962 people agreed that they had only feigned conversion. This also seems to me to be in line with the supposition that the Mbogoga Dani recognise that their ideas about supernatural phenomena may be incorrect.

Although people said their former religion was bad and appeared to have disliked the unrest and insecurity brought about by warfare, they obviously enjoyed describing and so re-living the rites and the fighting. The same attitude existed with regard to weapons. When the Wanggulam went to Mbogondini to burn them, they wailed 'to mourn their weapons'. People were also delighted to see *jao*, most of which they had thrown away because they were bad. 'Bad' as the Mbogoga Dani use it has at the least two interconnected connotations: it indicates not only that something is intrinsically bad and loathsome, but also, and in a more pragmatic sense, that it is useless and does not serve its purpose.

There was a striking degree of unanimity in the movement. Only very few people did not participate in it and not one openly condemned it. In the gatherings preceding the burning of weapons, the throwing away of the *jao*, and the abolition of the in-law avoidances, there was no dissension as to the desirability of these acts. To account for this unanimity one should realise that the motive underlying the movement — dissatisfaction with the culture — applies with equal force to all Mbogoga Dani. Also, all concurred in thinking that the Europeans enjoyed a vastly superior way of life.

By 1962 the Wanggulam realised that the days of the traditionally big men had gone. They denied that these men were still 'big'. In the

course of that year the mission pupils gained in influence. They were consulted on matters like marriage arrangements and people invited them to the steaming parties to preach. The influence the pupils had was limited: they were unable to prevent the people from throwing away the *jao*, and a number of people disregarded their tenet that people should not wear clothes before they really were Christians and knew the bible stories. The former big men took their loss in status grudgingly, but they did not oppose the movement openly. Other Wanggulam doubted the sincerity of their conversion.

The movement had not yet developed explicit political overtones. The Mbogoga Dani had not formed ideas as to their future relationships with government officials and policemen. Their appreciation of peace helped them to accept the government's presence without resentment. Acceptance was not hindered by government interference in the every day life of the people, e.g. in the form of forced labour or tax-paying. Acceptance was promoted by the improvement in the standard of living. The attitude towards the Europeans was ambivalent. On the one hand the people were grateful for the improvement in their welfare, due to the Europeans. On the other hand they disliked being denied entrance into the Europeans' houses and having to eat apart from them. 'They do not share their food'. The latent dislike could develop into a movement hostile to the Europeans. Hostility could also be promoted by disillusionment arising when it is seen that people continue to die. But it is difficult to predict how sharp the disillusionment will be, and thus to what reactions it will lead, as people do not appear to be very strongly convinced about their newly gained longevity.

## CHAPTER 5

### CONCEPTUAL FRAMEWORK FOR THE ANALYSIS OF WANGGULAM GOVERNMENT; AUTONOMY AND RECIPROCITY

For a definition of the concept of 'government' I draw on the views of M. G. Smith as developed in 'On Segmentary Lineage Systems' (Smith; 1956), 'Government in Zazzau' (Smith; 1960), and 'A Structural Approach to Comparative Politics' (Smith; 1966). His set of concepts is designed both to analyse specific governments and to compare them. Here I use it mainly to analyse Wanggulam government, and hence I do not discuss those parts of his writings directly concerned with comparison. Further I do not entirely accept Smith's conceptual scheme. Where I diverge from him, I will mention this explicitly. Smith defines government as 'the management, direction and control of the public affairs of a given social group or unit' (Smith; 1960, p. 15). This definition can be subdivided into three parts: 'the management, direction and control', 'of the public affairs', and 'of a given social group or unit'. I discuss these parts successively.

The 'management, direction and control' consist of two processes: politics and administration (Smith; 1960, p. 15). Politics is concerned with making decisions concerning policies, that is to say concerning plans or courses of action (Smith; 1960, p. 17). The groups, or people who try to influence the outcome of the decisions are political groups, or politicians. In their efforts to achieve decisions in accordance with their wishes, the political groups, or the politicians, oppose each other and compete for power. The more successful they are, the more power they have. Administration is concerned with the implementation of the chosen courses of action, the policies decided upon in the political process (Smith; 1960, p. 17). In order to perform this task the administration is organized hierarchically, while political action is taken in contraposition to competing groups or persons. Politics is always and

inherently segmentary (Smith; 1956, p. 48). Whereas politics proceeds through power competition, the administration is vested with authority; it has the right to enforce the implementation of a chosen policy.

Concerning the second part of the definition, 'the public affairs', the matters or issues with which a government is concerned, Smith holds that in any particular case it has to be discovered empirically what affairs are managed, directed and controlled. Likewise the nature and the extent of the social group or unit, referred to in the third part of the definition, is, in Smith's view, a matter for empirical investigation (Smith; 1956, p. 47). In his 1956 paper he seems to hold further that the groups or persons taking part in the governmental process are corporations, either corporations aggregate or corporations sole (see for example Smith; 1956, p. 66). In his 1966 paper he writes that 'corporations are the central agencies for the regulation of public affairs' (Smith; 1966, p. 120). He adds that they have the following characteristics: 'identity, presumed perpetuity, closure and membership, autonomy within a given sphere, exclusive common affairs, set procedures and organisation' (Smith; 1966, p. 117). In this same paper he introduces the concept 'quasi-corporation', which, next to the fully fledged corporations, may play a role in government. Smith provides a brief typology of the quasi-corporations (Smith; 1966, pp. 123-124). It seems to me that it might better be left to empirical investigation what types of groups or social statuses take part in government, rather than positing what the properties of such groups and statuses are.

In order to analyse the specific nature of Wanggulam government I have tried to formulate the fundamental values of the Wanggulam underlying their government. In doing so I draw on the analytical methods employed by E. A. Hoebel in his 'The Law of Primitive Man' (1954). Hoebel argues that each culture rests upon certain 'broadly generalized propositions . . . as to what is qualitatively desirable and undesirable'. He calls these propositions 'postulates' and argues that

The particular formulations of specific customs and patterns for behaviour that go into a given culture are more or less explicitly shaped by the precepts given in the basic postulates of that specific culture (Hoebel; 1954, p. 13).

He then starts the analysis of each of the legal systems discussed in his book with a presentation of the jural postulates, those postulates underlying the legal system. With this approach Hoebel is in accord with modern trends in sociology. Talcott Parsons for instance writes

That a system of value-orientations held in common by the members of a social system can serve as the main point of reference for analysing structure and process in the social system itself may be regarded as a major tenet of modern sociological theory (Talcott Parsons; 1960, p. 172).

I refer to the value orientations as 'principles'. In Western societies such principles are often explicit. In many Western states for instance a principle 'one man, one vote' is expressed and qualified in a great number of governmental procedures, laws and regulations; it is discussed in textbooks on constitutional law; and, in conjunction with others, it helps to mould the specific nature of the government of these states. Wanggulam principles are less explicit, and I had to construct them from scattered items of information and observed behaviour. They are not simply avowed guides as to what people should do, but in fact usually fail to do. There is consequently less distance between the principles as we can formulate them and the way government actually works than there can often be in Western societies. Furthermore, whereas the principle 'one man, one vote' in Western societies relates explicitly to government as a clearly delimited sphere of activities, among the Wanggulam government is merely an aspect of their whole social system and is not concentrated in specialised institutions. The principles underlying Wanggulam government may therefore relate also to other aspects, for instance the economic aspect, of their social system.

I centre the discussion of Wanggulam government on the following four principles:

1. Autonomy;
2. Reciprocity;
3. Competitive leadership;
4. Partnership.

All four principles are concerned with relations between people and all have a direct bearing on relationships of power and authority.

#### 1. *Autonomy.*

This principle formulates Wanggulam ideas about the place of the individual in society. It is concerned both with the individual and with his relations with other members of society. When analysing the government of a particular group of people, we analyse the public affairs of the members of this group and the way they are managed, in other words we are dealing with those affairs the individual is not

allowed to manage for himself. We might complement this picture indicating what is the proper concern of the individual; what is the role of the individual in relation to the group, and, conversely, what is the role of the group in relationship to the individual; and, finally, we might indicate the ideological foundation for allotting affairs to the group, to one of its sub-groups, or to the individual.

Wanggulam have a strong feeling of being their own masters. The ultimate means of force in their society rest with the individual adult members. There are no functionaries or groups of functionaries with a monopoly of the means of force. People do not refrain from using force, and the number of fights, whether with fists, or with clubs, or with bows and arrows, is large. They often occur between close relatives, for example between full brothers, and people do not object to such fights. Intervention in fights occurs rarely. Transgression of the rights of members of society are not met with by the interference of a special instrument of government, but by action of the wronged person himself, possibly with help from one or a few of his co-parishioners.

Among the Wanggulam there are no permanent institutions and functionaries to which members of society owe obedience. Claims on the members of society are not made by officers of government and in the public interest, but by the other members of society and in their own private interest. The claim is the result of the relationship of the people involved and is based upon their previous transactions.

Autonomy provides the adult Wanggulam with a wide range of affairs which they manage without interference from others. There are few public affairs among the Wanggulam. Big men have only a small extent of power and authority and do not dispose of a much greater force than other men do. When the advice of a big man is followed, people are inclined to say that they complied voluntarily. Also, when communal action is taken, big men may have no prominent role at all, as appears for instance during the Sunday meetings organised by the missionaries. These meetings are preceded by much joyous dancing in which most of the men and a number of women participate. The dances themselves consist of running round and round; a few men in the centre act as precentors, and are answered by yells from the dancers. Only the precentors display coordinated rhythm. People go to the meeting by themselves or in small groups. At a distance from the grounds, the men usually wait for the other men of their section or parish, so that the men of one parish ultimately reach the grounds in one or a few groups, in which formation they join the dancers. One

man sets the pace, but he does not go ahead; the group moves in closed ranks. During the dances the groups merge completely.

I was told that in discussions about joint undertakings people attempted to reach a unanimous decision. If a man cannot agree he is likely to withdraw from the venture, or to perform his part of the undertaking according to his own wishes. When deciding upon the location of boundaries between gardens and between parts of gardens the makers of neighbouring gardens settle the matter among themselves. They trace the approximate course of the boundary before clearing the tract and afterwards decide upon its exact course. I was told that on one occasion a man had not taken part in the opening of a garden, because he had not been warned that the approximate course of the boundaries would be discussed. At the discussion the other gardeners had reserved a part for him, but he had refused to make use of it. This man was one of the juniors of the group. A woman does not partake in discussions concerning garden boundaries, but she can influence the outcome indirectly by urging her husband not to give up the fertile plot he had used before, or to try to get another and better one. Women may also reallocate the plots, or part of the plots, when they start planting. That men are reluctant to implement a decision that does not accord with their wishes, appears also on occasions like the distribution of food or riches. When, after sometimes long discussions, a man still disagrees with the procedure taken, he shows this by ignoring the further events. If he himself has contributed, he may distribute his own contributions according to his own judgment.

In everyday life the autonomy of the individual Wanggulam appears in the great ignorance people profess about each other's activities and whereabouts. People do not take each other into their confidence. They try to keep their plans to themselves, if necessary by deceiving others. Conversely, they realise that other people also want to keep their plans to themselves and, in order to do so, are prepared to deceive. People dislike meddlesomeness, as it implies encroaching upon others' affairs. This attitude was to some extent abandoned during the climax of the religious movement when the mission pupils began to urge the Wanggulam to confess in public in order to be converted. A number of men did confess, relating the killings they had taken part in. The women however did not confess their *mum* activities. Although people resented this, scarcely any pressure was exerted upon the women to confess.

I did not find a word approximating 'autonomy' in the Dani language.

Accordingly my remarks concerning these concepts are based on the behaviour and the verbal information of the Wanggulam. Neither did I find a word approximating 'dependence' or 'inferiority'. The only term implying a position of inferiority, *eiloman* (see p. 19), refers to the feeble-minded men who are under the guardianship of their *apulit ewe*, their 'false + B'. *Eiloman* are looked down upon, and one would not like to be in their position. I mentioned above that often there is no affection between adult brothers, and that they often do not live together. This seems to indicate that a younger brother may see an elder brother as a threat to his autonomy, as is demonstrated in the relationship *apulit ewe-eiloman*.

The autonomy of the adult Wanggulam is not absolute. There are a number of occasions on which he submits to authority, whether exercised by big men or by others. Originally I used the term 'sovereignty' to indicate the phenomena referred to above under the heading of 'autonomy'. I decided to replace the term 'sovereignty' by 'autonomy' after it had appeared that the former term carried an incorrect connotation of absoluteness, implying a total lack of subordination which would mean the absence of government among the Wanggulam. Autonomy is tempered by the other three principles. We should further distinguish between autonomy as it appears from statements of the Wanggulam, and as it appears from their actions. It seems to me that the Wanggulam are inclined to overstate the autonomy pertaining to the members of their society. Wanggulam tend to give the impression that they follow a big man voluntarily; and that they do not feel obliged or forced to follow him. This attitude extends to personal rights and duties between individual Wanggulam. For example, a man who is about to hold the first wedding ceremony for his daughter says that it is up to the others to decide to contribute to the *uak* and with what items. Also, a person who has rendered a prestation will say that the recipient is free to decide whether or not to reciprocate. Nevertheless in all such situations a man does expect others to render him prestations: a man does expect that his closest kin and neighbours contribute to the *uak* for his daughter; that the men from his hamlet join his work party; and that his prestations will be reciprocated. There will be resentment or retaliation if his expectations are not met. One of the reasons why people cooperate with others and reciprocate their prestations is that they want to avoid resentment and retaliation. Linton reports about the Comanche that they 'attached tremendous importance to individual freedom of action', but that the Comanche band 'was

better organised than it was willing to admit' (Linton; 1936, pp. 228-229). The same might hold true about the Wanggulam and their parish. Autonomy pertains only to the men of over about 25 years of age. Most men are married at this age and have been active in fights and battles. Until this age they are not free to leave their father (see Case 3, p. 83). I never heard of tension arising because a father had tried to dominate his son, but an important factor here is that usually a father is on the decline when his son is about 25 years of age.

A young man grows into a fighter through a number of '*rites de passage*'. At a very early age, about four, he is presented with a bow and arrows, apparently without further ceremonial. There are a number of yardsticks to measure his proficiency with this weapon. A boy starts by just trying to hit fixed objects; next he starts to shoot birds. When he has succeeded in shooting his first bird, people say, he runs to his father, in excited pride, to tell him. The next step is taken when he joins the men when they go hunting and tries to shoot marsupials and wild pigs. The final step is the introduction to the battlefield. During a battle the youth is called up by his father or elder brother, alongside whom he has to fight. His father or elder brother watches him and instructs him only if it appears that he is a clumsy fighter. Other men do not interfere: they keep an eye on the performance of the youngster and judge him accordingly. A common way of killing a captured enemy is for a few men to hold him fast while others shoot him from a couple of yards' distance (compare Matthiessen; 1962, p. 110). 'To learn it', as the Wanggulam say, young men are invited to be one of the killers. In this training there is a minimum of instruction: a boy learns shooting by practising for himself and imitating others.

With this form of initiation common action is not taken: there is neither a group of initiators, nor a group of initiandi (this contrasts sharply with the situation among the Dani living in the Grand Valley among whom initiation ceremonies form part of large scale pigfeasts (Peters; 1965, pp. 133-147)). The right to introduce a young man to the battlefield rests with his father, or, if the father has died or is residing elsewhere, with an elder brother. The other members of the group merely look on to judge whether the novice will be a worthy adult or not, they do not take a direct part. The initiate and his personal capacities are the centre of the interest, and not the group. Nevertheless the matter is of great interest to the men; a good performance on the battlefield gives a Wanggulam the highest social esteem he can acquire.

It seems that autonomy is also an attribute of women. Although they do not have bows and arrows, women dispose of a formidable means of power: *mum*. People try to avoid a woman's anger, lest they be killed by *mum*. Just as men do not command each other, so they do not command women. When they want women to do something, they try to persuade them; for example men try to persuade women to go to the fields to dig potatoes, or they try to persuade a girl not to run away from her husband. During the distribution of the wedding payments women often advise their husbands. I have mentioned also the important voice a wife has in the use of the assets she and her husband have at their disposal.

## 2. *Reciprocity.*

Claims people have on each other, both in friendly and in hostile relationships, are gauged by the criterion of reciprocity: for a service rendered an equal service should be paid back; a counter action should aim at a retribution equal to the wrong suffered. In the preceding chapters I mentioned the importance of reciprocity in regard to contributions to wedding payments and economic co-operation. The function of reciprocity is not merely that it defines the size of claims and obligations, but people associate the occurrence of friendly relationships with the reciprocal exchange of goods and services. People who are on good terms exchange with each other, whereas a refusal to exchange, whether expressed by ignoring obligations or declining a request, is interpreted as a sign of being ill-disposed. Although good relationships presuppose exchange, exchange itself does not necessarily lead to good relationships. People do not expect that others will readily meet the full extent of their obligations, and they complain often that they have been wronged. Reciprocity pervades hostile relationships too. The Wanggulam conceive of their relationships with their neighbours as consisting of long series of reciprocated acts of hostility. Fights are explained as resulting from former fights or former killings, even though people do not always know the facts of the case. The chain of hostilities was not always continuous, and might be concluded by the transfer of compensation, but in these hostile relationships absence of hostile actions was not interpreted as absence of hostile feelings: Wanggulam think of their relationships with neighbouring parishes as permanently hostile.

In many Melanesian societies reciprocity, together with the equality

of the members of society, has been noticed as of great importance, and, according to Pouver, reciprocity implies equality (1961, p. 11). Yet it seems that reciprocity can exist also in relationships in which inequality prevails, as long as both partners, and not only the subordinate, are obliged to render their services, as for example in the relationship between the government of a Western state and its subjects. The latter are obliged to render services like taxes while the government has to provide, for example, social services (compare Malinowski; 1934, p. xxxviii). The reciprocity prevailing in Melanesia seems to be a special mode of reciprocity moulded by the equality of the members of society.

According to the Wanggulam good relationships are marked not by a single pair of reciprocal actions, but by a continuing flow of reciprocations ('When you stop giving each other things, you soon drift apart', see p. 24). This is also expressed in the marriage regulations: Penggu and Karoba continue giving each other their women, thus merely reaffirming an existing relationship, while peoples like the Kyaka and the Enga seem to be keen on establishing new relationships with each marriage (Bulmer; 1960, pp. 4-5). The Enga would probably consider the Wanggulam marriage system a waste of bridewealth (Meggitt; 1958, p. 277 and 1965, pp. 95-96).

Before discussing further implications of autonomy and reciprocity, I will describe the third of the principles mentioned, competitive leadership.

## CHAPTER 6

### COMPETITIVE LEADERSHIP

The most important, and the most visible, leaders among the Wanggulam are the big men. The main part of this chapter is concerned with a discussion of their position. First I present the qualifications on which their leadership is based, secondly the public affairs in which they act as leaders. At the end of the chapter I discuss other categories of leader, and finally categories of inferior and subordinate men.

#### *Big men*

Wanggulam say that the big men, *ap ngwok*, are those who kill. Men who do not kill are 'small men', *ap mbuluk*. The more people a man kills, the bigger he grows. Although not all big men are equally big and although most Wanggulam consider one of them, Wandin, to be biggest, they do not further rank the big men in an explicit order. In other parishes the same situation seems to occur.

The existence of men comparable to the Wanggulam big men has been reported from a great many New Guinea Highlands societies. In most cases fighting ability is an essential prerequisite for becoming prominent. Often these men are referred to with the same term: 'big men', as among the Chimbu (Brown; 1963, p. 5). In the following discussion I will use this term to refer to all such men. Many Highlanders contrast 'big' and 'small' — as the Wanggulam do — or 'weak' and 'strong' men, and range the male members of society along a continuum extending between these poles. This occurs among the Eastern Dani (Bromley; 1960, p. 239, and Peters; 1965, p. 82), the Gahuku-Gama (Read; 1959, p. 433), the Huli (Glasse; 1959, p. 278), the Mbowamb (Strathern; 1966, p. 357), and may be among the Kyaka (Bulmer; 1961, p. 354).

The fighting records of the individual Wanggulam men show that in Mbogoga other qualifications besides killing are required. The killer must not be mentally deficient. A halfwit may be brave and kill a number of people, but he will never become a big man. Moreover,

the killings should have occurred recently: retired killers lose their status. The biggest Wanggulam are all killers who have successfully organised a raid or a battle. People do not explicitly mention this ability as a prerequisite for outstanding bigness.

Supplementary qualifications are:

a. *Verbal skill, the ability to state relevant arguments with clarity.*

Oratory in itself is not in high regard. This contrasts with other Highlands societies where oratory may be highly regarded. Kuma, for instance, refer to their big men by 'rhetoric thumpers' (Reay; 1959, p. 113). Oratory is an important qualification among also the Uhunduni (Ellenberger; 1962, p. 14), the Kapauku (Pospisil; 1958, p. 80), the Gahuku-Gama (Read; 1959, p. 431), the Chimbu (Brown; 1963, p. 5), the Kyaka (Bulmer; 1961, p. 345, and 1960, p. 7), the Siane (Salisbury; 1962, p. 28) and the Mbowamb (Strathern; 1966, p. 358).

Among the Wanggulam, talkative people who are inclined to comment favourably or unfavourably on the latest events, are disliked. Such people are presumed to be cowards. On the other hand, the man 'who is silent and regards one darkly' is presumed to be a killer.

b. *Industry and agility.* Big men have a forceful physique and are in the prime of their life, that is to say between 30 and 50-55 years of age. This is reported by almost all of the writers mentioned (Bromley; 1962, p. 5, Pospisil; 1958, p. 59, Brown; 1963, p. 6, Reay; 1959, p. 116, Bulmer; 1961, p. 329).

Skill in manipulating supernatural forces may promote a man's status; among the Eastern Dani the big men are the makers of 'war-magic' (Bromley; 1962, p. 3, see also Heider; 1962, p. 17). Big men tend to be sorcerers among the Kapauku (Pospisil; 1958, p. 25), the Kuma (Reay; 1959, p. 150), and the Kyaka (Bulmer; 1961, p. 350), but not among the Chimbu (Brown; 1963, p. 6). Among the Mbowamb big men have the 'right to say prayers to the ancestors on public occasions' (Strathern; 1966, p. 358). Among the Wanggulam the big men are successful performers of the *amulok kunik* rite, but the people attribute success to bravery and the disposition of ancestral spirits, and not to a special ability in performing the rite.

The Wanggulam admire men who can make an impressive public appearance on account of their personal abilities, whether through verbal skill, manual skills, or leadership. Young men usually refrain from appearing in the public eye. For example during a feast at which sugar cane was to be distributed, Wandin called the young men to come to get the sugar cane, and to take it to the centre of the feasting

ground. He had to yell for quite some time before he got them to do this. I interpreted it as indicative of a lack of power, but for the young men the important point was that they had been afraid to come and get the sugar cane while everybody was looking on.

In daily life Wanggulam big men are not distinguished by dress or finery. They work at least as hard as other people. They are mostly polygynous and wealthy, but they are not set apart by having appreciably more wives and wealth than lesser men. By 'wealth' I refer to title to larger than average gardens, to ownership of more than average valuables like shell bands, *jao* and pigs, and also to a larger than average role in the circulation of these valuables. In 1962 a big man owned on an average, 2.0 pigs, a small man 1.7. A big man had 1.8 wives, a small man 1.4. Nor do big men play a prominent part in the exchange of valuables. The Wanggulam themselves deny that having a wide range of exchange relationships makes a man big. Here is an important difference with other Highlands societies where big men are more marked out by polygyny and wealth, either in actual possessions or in command over goods. Peters asserts that among the Dani of the Grand Baliem Valley polygyny is the prerogative of the big man (Peters; 1965, p. 35). Pospisil states that among the Kapauku 'polygyny . . . is indispensable for the acquisition of political and legal authority' (Pospisil; 1958, p. 135). Kapauku big men derive their greatest prestige and following from being wealthy (Pospisil; 1963, p. 45). Kyaka men 'can achieve positions of considerable prestige and influence within their clans and even outside clan confines by their skill in manipulating pigs and valuables in loans and exchange transactions' (Bulmer; 1960, p. 5). Among the Enga big men exert power calling on the support of their debtors (Meggitt; 1957, p. 136). Among both Enga and Kyaka polygyny offers advantages for the acquisition of power (Meggitt; 1965, p. 87, Bulmer; 1961, pp. 340-344), primarily because a polygynist can extend his exchange relationships over several sets of affines while, with the help of his wives, he can run a large herd of pigs. Bulmer mentions explicitly that Kyaka big men have appreciably more wives than other Kyaka men.

In his general characterisation of the Melanesian big man, Sahlins devotes most attention to the economic aspect of the big man's status. This writer stresses that a Melanesian man makes a career 'creating followership', and building up a faction upon which he can 'prevail economically' (Sahlins; 1963, p. 291). His faction consists initially of his own household and his closest relatives and the big man does his

utmost to enlarge the household with additional wives and "strays" of various sorts'. In Sahlins' terms 'A big man is one who can create and use social relations which give him leverage on others' production and the ability to siphon off an excess production' (Sahlins; 1963, p. 292). Although this characterisation may fit the big men as they occur in other Highlands societies, it is not applicable in Wanggulam society. A Wanggulam big man does not dispose of a group of followers, or a faction, although he often has an *eiloman* or a small man living with him. The absence of a group of followers impedes any possible effort to enlarge agricultural production by opening large swiddens. A Wanggulam big man is not able to muster the work force necessary. Finally, a Wanggulam big man does not act as a financier. I mentioned for example that wedding payments are assembled by the man who reared the bride or the groom, if he is still alive at the time of the wedding. From the accounts of compensation payments it appeared that these were assembled by the offender or one of his close kin. In neither case did big men appear to be instrumental in assembling the payments. Since Wanggulam big men do not act as financiers, they cannot put economic pressure upon others and make their debtors become their followers. Thus compared with big men in other Highlands societies, an important method of gaining ascendancy is denied to them.

In many ethnographic reports a slight specialisation among big men is referred to. Ellenberger and Pospisil (writing on Uhunduni and Kapauku) mention a differentiation between 'war-leaders' and 'wealthy leaders' (Ellenberger; 1962, p. 15, and Pospisil; 1958, p. 81). Among the Eastern Dani a specialisation seems to occur between warleaders and men with great supernatural gifts (Bromley; 1962, p. 3). Among Chimbu also warleaders are marked out from leaders at dances and distributions (Brown; 1963, p. 6). Specialisation does not occur among the Wanggulam: disposing of a special skill is admired, but skill in fighting is more important than any other skill, especially when it is combined with abilities as a leader. The position of Wandin, the biggest Wanggulam, as stated in the next case, may serve as a further illustration.

#### CASE 2, THE POSITION OF WANDIN

Wandin, a Penggu, is an eldest son. He has two younger brothers who do not live in his hamlet. The elder of these two brothers is also a big man, though not as big as Wandin. Wandin is about 40-45 years of age, and of great physical strength. He is a reputed axeman, and

a hard worker. In March 1961 Wandin had three adult pigs. He has married three women, his third wife being a widow he married after his first wife died. His FF, or FFF, was not a Wanggulam, but his FM, or FFM, remarried with a Wanggulam after her first husband died. The children of her first marriage stayed with her and 'became' Wanggulam. He told me he had been involved in the killing of 24 people. There were other men in Wanggulam who had been involved in more killings, but all these men had stopped their warlike activities a number of years ago, whilst most of Wandin's exploits took place during the last 15 years. Moreover Wandin has been the organizer of all the large-scale raids the Wanggulam undertook during the last 15 years. Wanggulam consider these raids to have been successful, and attribute this to Wandin's leadership. Yet Wandin is not the biggest man in the whole of Mbogoga.

During the years preceding my stay the greatest leader among the big men of the Mbogoga parishes had been Jikwanak, the biggest man of the Tukobak (see p. 2). Jikwanak had led the Tukobak when they chased the Wanggulam from Mbogoga, causing the death of at least ten Wanggulam. After their return the Wanggulam, led by Wandin, had taken revenge. In two fights they killed five or six Tukobak. The last series of fights which occurred before the pacification by the Dutch administration in 1960 started between Wanggulam and Tukobak. In a sneak attack a number of Wanggulam killed a Tukobak. Wandin was not among the fighters. He merely performed *amulok kunik* and observed the course of the attack from a lookout. Many Wanggulam described these fights as yet another revenge for the losses they had incurred almost twenty years ago, but Wandin himself explained that it had had to do with the troubles between the sons of Engginduk and the Bagawak section of the Tukobak (see Case 22, p. 163). Engginduk had been a member of a small Penggu section and one of his sons had asked Wandin, his classificatory brother, for support.

When the Ngopare were still living at the upper Kurip River Wandin supported them successfully, performing *amulok kunik* in their war against the Penggu-Kumaungga, a section pair living on the opposite bank of the river. The Ngopare killed two of these people and, afraid that the latter would try to get revenge by working *mum* or by a sudden raid, they asked (as the Wanggulam put it) Wandin whether he would allow them to settle upon Wanggulam territory, and he agreed.

Finally, Wandin led the Wanggulam successfully on a revenge raid to the area near Lake Archbold. Probably eight Wanggulam — six Karoba men, of whom four were from Karoba II, together with the wives of two of these — had been killed while they paid a trade visit to the Ngem, people living near Lake Archbold. Kwamok, the biggest man of Karoba II, had managed to escape and asked Wandin, who has an expert knowledge of the jungle tracks, to lead a revenge raid. The raid was a great success; Wanggulam told me that more than ten Ngem were killed.

The men and adolescent males living together with Wandin are his eldest son, who is in his late teens, and two classificatory sons, the elder of whom is *jeget nungganggen*. Finally there is a feeble minded bachelor of about 30 years of age who is Wandin's *eiloman*. Wandin can be very witty and to the point. He can behave very extrovertly; during the revival of the religious movement in 1962 other men required him to confess his fighting activities by producing the names of all the people he had killed. He had to represent these people by pebbles he threw on a heap. Then he threw them in the bush saying that he had done away with killing. But immediately afterwards he tapped a few young men, the same who had spurred him on to confess, on their heads, and said: 'Why did you trim your hair and throw away your headbags' (see p. 61). 'Formerly when I saw a man with furstrap and feathers, and with long hair I felt already like killing him'. He wailed. The other men present were taken aback. They seemed to think that Wandin had conveyed his feelings very ably. The incident struck them a great deal, and they kept talking about it saying that Wandin was really a big man of the old stamp, and would not go over to Christianity.

It should be noted that Wandin owes his status not to initiating a new series of hostilities, but to waging successfully a number of retaliations. Doing this, he rendered the Wanggulam great services: he gave individual Wanggulam the opportunity to get revenge for their killed kinsmen. Moreover, the accounts of the Wanggulam of former fights and raids gave me the impression that they enjoyed having been members of a strong parish which had been successful on the field of battle.

I do not know if this aspect of Wandin's career is typical for Wanggulam big men. This may well be so, since the Wanggulam appear to consider hostilities, both between and within parishes, as interconnected chains of retaliation (see p. 133), in which raids and fights are counter-actions for former wrongs. If Wandin is typical in this respect, then an aspiring big man, who wants to make a career as a successful fighter and war leader, has to exploit those situations in which his own parish can retaliate.

A Wanggulam man aiming to become big starts his career about the time he marries. Until then he is under the authority of his father, or — if his father had died — his father's brother or his own elder brother or some other relative. Shortly after his marriage a young man starts a household of his own: he builds a house for his wife, usually in his father's hamlet, and he starts to contribute to and receive from wedding and other payments. At about the same time he begins his warlike achievements. When he turns out to be brave and a success-

ful fighter, the older men realise that he is *jeget nungganggen*, that he will probably become a big man. Before he is really big, he should have participated in a number of killings; for this reason there are no big men under the age of about 30. It has already been noticed that a man's career may be hindered by the fact that bravery is attributed to the support secured by the *amulok kunik* performed by an elder brother (see p. 48). As a man has to live up to his reputation, he has to go on fighting and killing and he loses his power soon after he becomes too old to be a good fighter. There are two ways in which he can retain power; first by joining in discussions and by giving valuable advice, secondly by performing *amulok kunik* for others (see p. 48), but only a few big men manage to maintain their power past the age of 50 or 55. In 1962 there were 74 Wanggulam men between the ages of about 30 and about 50-55. Twenty of these men were said to have been big before fighting came to an end in 1960. This means that 27.0 % of the men of this age group reached a position of prominence. The percentage seems high, but among the Kuma 'three-fifths of the parental generation — that is, three-fifths of the mature men between thirty-five and fifty five — are leaders' (Reay; 1959, p. 116). Bulmer mentions that among the Kyaka 34 of the 170 'adult' men, that is to say 20 %, are prominent (but this group may include men under 30 years of age). For the other peoples figures are not available.

Among the Wanggulam 19 out of the 20 big men belonged to the main sections, Penggu and Karoba. People said that Mabu and Ngopare did not include big men 'because' they were small, but at the same time they did not exclude the possibility of Mabu or Ngopare men becoming big.

The Wanggulam tend to say that the son of a big man in his turn becomes a big man. I found it impossible to check this statement as the information about the status of dead men turned out to be unreliable. Several men who were said to be *jeget nungganggen* and so could have become big men, were the sons of — still living — small men. That a big man may be the son of a small man is acknowledged by the Wanggulam themselves, who point out that the essential thing is to be a killer. Hereditary advantages seem to be few: during his childhood and adolescence the son of a big man is in a favoured position to learn from his father, and — since people ascribe success in battle partly to the disposition of ancestral spirits — they may trust that the son will be as successful in securing his ancestors' support as his father

was. Wanggulam realise that the son may be a coward in which case he does not become a big man.

Other Highlands peoples also assert that prominent men have prominent fathers. The Kuma for example assert that sub-sub-clan leaders are succeeded by their eldest sons. However, this is not borne out in practice (Reay; 1959, pp. 113-115). The Kyaka say that a big man is not necessarily a big man's son (Bulmer; 1961, p. 333). Among the Kapauku people profess ignorance about the identity of the future leader (Pospisil; 1958, p. 110).

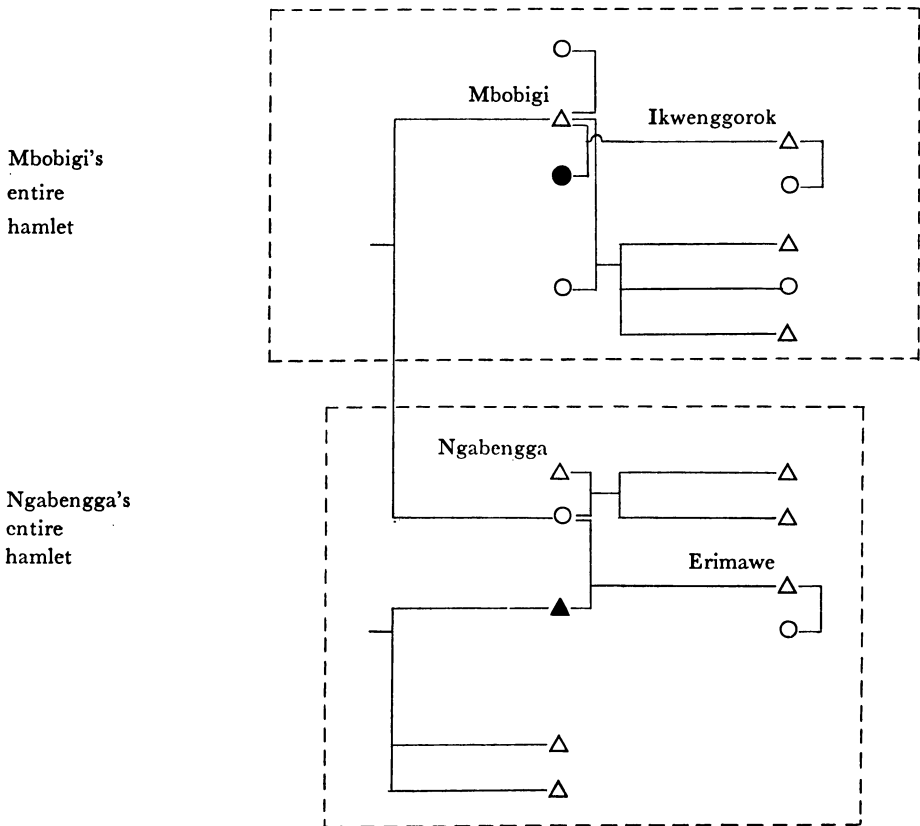

FIGURE 6: INHABITANTS OF MBOBIGI'S  
AND NGABENGGGA'S HAMLETS IN DECEMBER 1961

I present the next case to show how men pass from adolescence into adulthood.

CASE 3, MBOBIGI, IKWENGGOROK (his son), AND ERIMAWA (his sister's son)

Mbobigi is an elderly, subdued man. He is not a big man, nevertheless he is wealthy and at the beginning of 1963 owned four adult pigs, although he had recently given a number of pigs to the bride prices for the wives of Ikwenggorok, his son, and Erimawe, his sister's son. The genealogy of figure 6 indicates all inhabitants of his hamlet and of Ngabengga's hamlet. Erimawe's F-B lives at some distance, close to the easterly boundary of Wanggulam. Ikwenggorok married in December 1960. He was about 20 at that time. Initially his wife lived in the house of Mbobigi's third wife, her classificatory +Z. In the end of 1961, when she was pregnant, Ikwenggorok built her a house, also in his father's hamlet.

Erimawe married in March 1961, but his wife did not like him and she ran away. He remarried during the second part of 1961. Ngabengga, his mother's second husband, is a starveling who did not pay a bride price for his mother. He lives in a hamlet on Mbobigi's territory. Mbobigi helped Erimawe to collect a bride price, because the latter was still with him. Erimawe had left his F-B after his mother had married Ngabengga. It is usual in such a case that a boy returns to his father's close agnates when he becomes adolescent. Grateful for the support he got from Mbobigi, Erimawe did not leave the latter after his marriage. In 1961 his second wife got her own house in Ngabengga's hamlet. Another reason for Erimawe not returning to his F-B was that he felt that his agnates had not supported him sufficiently in raising a bride price. On that account he grabbed a *jao* which one of his F-B displayed in the men's house of his hamlet (to pay for his second wife), got away with it, and added it to his own collection. This and other bold manoeuvres made the Wanggulam think that Erimawe was to become a big man. In 1961 he was about 20-25; he had — before the arrival of the Europeans — killed one man which marked him as rather brave.

Erimawe married at a late age and, unlike Ikwenggorok, already before his marriage he participated in the transfer of ceremonial payments. In 1961 Mbobigi, Ngabengga, Ikwenggorok, and Erimawe joined to make a complex of gardens north of Mbobigi's hamlet. In May 1962 Erimawe fought the second husband of his first wife. After she had run away, her father had been unable to recover all the individual items of the bride price. These were to be provided by the second husband, but this man was slow in paying while Erimawe needed the valuables to pay for his second wife. Erimawe wounded the other with an axe, and the man went to the government officer to complain. As a penalty the police burnt down Ngabengga's hamlet. Ngabengga and Erimawe and their families went to live together with Mbobigi. Erimawe's wife joined Ikwenggorok's wife, Mbobigi's sister (Ngabengga's wife) joined Mbobigi's third wife. At about the same time Ikwenggorok and Erimawe started to make a garden east of Mbobigi's hamlet. Mbobigi himself started to make a garden on his own north of the hamlet. He was not helped by Ikwenggorok and

Erimawe, nor did he help them. He denied that they had informed him about their plans. Also at this time the men started to build a new hamlet which was to house them all. Then it was said that Ikwenggorok and Erimawe still would not leave Mbobigi, 'who brought him up'. The case shows, that — notwithstanding their economic independence — the two young men are still under obligations to Mbobigi, and this on account of his efforts in rearing them.

The public affairs in which the big men exert power and authority are few. I categorise them as follows:

- a. raids and battles;
- b. large scale harvest feasts;
- c. other, extraordinary events.

I discuss these affairs in the abovementioned order.

a. *Raids and battles.*

I never witnessed either a raid or a battle or a situation in which a raid or battle was likely to develop. My data contain many accounts of hostilities which took place before my stay among the Wanggulam, but these concern mainly the hostilities themselves and contain few references to their preliminaries, the role of the big men in the preliminaries and the policies they used to get people to follow them. I was told that waging a fight was decided upon during gatherings at which the big men, and only they, spoke and set out a plan of campaign. They reputedly incited others by their enthusiasm but also used their physical superiority to threaten them and to prevent them from defecting. It should further be noted that in many — if not most — cases people were disposed to join in, because the fight was seen as an act of retaliation. During battles and raids themselves the role of the big men is less important, because in the turmoil they are unable to control the other men. Before the battle and during the initial skirmishes they perform *amulok kunik*, and hand out the consecrated arrows.

Battles are ended or adjourned at dusk. If no death has occurred during the fighting, a big man calls out to the other fighters to adjourn or to stop the fight. When death has occurred the big men lose their initiative in the matter; it is up to the closest relative of the killed, usually his father or brother, to decide whether to adjourn the fight or to end it and ask for compensation. It seems from the accounts that the big men have the most important role during the gatherings, but here too they were not the only powerful men; they had to overcome the objections of others. In Smith's terminology this would mean

that the big men are not in a position of authority: they do not have a right to implement the plans of campaign they themselves have decided upon, but they have to persuade the men present that their plan is a good one so that the latter will accept it.

During the gatherings I witnessed, for example during the festivities organised by the missionaries, order was lacking for a considerable part of the time. There was no single man who could command silence for more than a few minutes. It was clear that it is a distinct advantage for a Mbogoga Dani to be able to be concise, since the voices of longer-winded speakers were soon lost in the discussions of the other men present. It might be argued that this was a recent development due to the decline in power of the big men (see p. 64). This does not seem probable as the noisiness and lack of order during a gathering was so much regarded as a part of their own culture that — for this reason — people thought it had to be done away with in the process of conversion to Christianity, just as the *jao* had to be done away with and the in-law avoidances had to be abandoned (see p. 62).

b. *Harvest feasts.*

During my stay three large scale harvest feasts were held in Mbogoga. All three occurred in 1960. Later the Dani refrained from holding them because the missionaries reputedly disliked the feasts as they would stress the greatness of the big men instead of the greatness of God. As a substitute the missionaries organised a number of comparable feasts at the mission station. One of these feasts triggered off a revival of the religious movement in 1962. The feasts were linked in that gifts made during one of the feasts were reciprocated during the next ones. The oil pandanus feast I will describe was preceded by two cucumber feasts and would have been followed by other oil and nut pandanus feasts, but for the feelings of the missionaries.

Similar interconnected feasts have been reported from several parts of the highlands, both from East and from West New Guinea. But so far there are no reports from West New Guinea of a sequence of feasts linking a chain of feast partners like the Enga Moka (Bulmer; 1960, p. 5) where exchange is indirect and reciprocal gifts are made in a following cycle of feasts, a number of years later. Among the Mbogoga Dani feasts are organised by one parish, or part of a parish, and people from over the whole of the valley attend. Exchange is direct and people expect reciprocal gifts to be made at one of the next feasts. Although most of the feasts are held during the months following the

garden making season (see p. 25), there is no distinct cycle of feasts. The Wanggulam say that the feasts held in the valleys surrounding Mbogoga are organised in the same way as those held in Mbogoga itself. Every now and then rumours reached Mbogoga about gigantic feasts held in, for instance, the Swart Valley. Together with a large number of Wanggulam I visited a nut pandanus feast organised by a group of people living in the uppermost reaches of a Swart tributary. Another feast I witnessed was held at the mission station at Karubaga (see map II), also in the Swart Valley.

Mbogoga feasts have a number of characteristics in common:

1. They culminate in the distribution of one agricultural product.
2. One group organises each feast and provides most of the distributed food. A section which organises such a feast can enlist the help of a smaller section united to it by marriage ties. Penggu section held this particular pandanus feast with the co-operation of the smaller Ngopare section.
3. One big man directs the distributions. At the traditionally organised feast held in the Swart Valley, the distribution was the affair of each individual married couple. Each couple had brought in a certain amount of nuts and both spouses had a say in its disposal.
4. The directing big man concludes the distributions with a speech stressing the unity of the people present, the evil of fighting, and the desirability of maintaining peace.
5. Dances precede and follow the distributions.
6. The products to be distributed are displayed: the men who bring them around show them lifting them over their heads.

#### CASE 4, OIL PANDANUS FEAST ORGANISED BY THE WANGGULAM PENGGU

The feast was held in the beginning of December 1960. Already some weeks beforehand people started talking about it: about the number of pandanus fruits which would be distributed; about the length of the stack of firewood on which the cooking stones would be heated; about the number of earth ovens which would be required. Because I wondered how people came to an agreement over the date of the feast, I asked several men how many days from then the feast was to be held. The men I asked, including Wandin who later directed the feast, did not refer to any agreement and tried to figure out the date by calculating how many days the preparations for the feast would take. Although they had taken part in several feasts and were acquainted with the way to organise them, all their calculations proved to be wrong.

Before a feast is held, a prohibition on the further picking of pandanus fruits is issued, reputedly after a meeting of the adult men of the section. Normally pandanus fruits are picked as soon as they are ripe because people expect others to steal the ripe fruits. Therefore watch was kept to see that no fruits were picked. During the last days before the feast people collected cooking stones and firewood with which they built a stack. The day before the feast they picked the fruits which were collected in two houses near the feasting ground. The long row of men carrying the fruits from the orchards to the houses was visible from the other bank of the Kurip, where it caused great excitement. Yells resounded and people took on a festive mood.

In Wanggulam there are a few areas, but no fixed spots, where feasts are preferably held. The present feast was held near the area where, according to the Penggu tradition, the ancestors had settled down after reaching Mbogoga on a trek from the Baliem Valley, and from where they had later dispersed over Mbogoga (see map V, P).

On the morning of the feast many preparations had still to be made: at the feast ground almost all Penggu men were present, working. Some were digging an earth oven (see map VI), or collecting leaves for the dressing; others were preparing pandanus for steaming. There were no women present: they were working in the gardens digging potatoes and collecting potato leaves to be cooked together with the pandanus.

At the end of the morning ten ovens were dug. All were owned by one or more men. Most owners were Penggu, the other owners were men associated with Penggu. Not all members of Penggu section participated: one subsection was entirely absent, allegedly because they had no pandanus fruits, and Jiwaru did not participate. He does not own many pandanus trees and had asked Wandin to give him some fruits, which Wandin had refused (see p. 101). Jiwaru got very angry over this refusal. In the next chapter I will give a more extensive description of the role of kinship and residence regarding joint ownership of the ovens.

In the course of the morning many visitors arrived. All brought small contributions with them: wooden tongs to carry the heated stones from the fire to the ovens, or leaves and grasses to be used in filling the ovens. Karoba, as Penggu's ally, were the only guests who brought more costly presents: a number of pandanus fruits ready to be steamed. The Karoba arrived in two groups, which were not formed on kinship lines; their arrival was acknowledged by loud yells.

Four groups of participants could be distinguished:

1. Adult men, busy with oven or pandanus fruits, and working individually.

2. Adolescent boys, fetching still more tongs, leaves and grasses, and so on. Most worked in either of two groups. To observe these groups working was very impressive. The members collected things individually, and on their way back they waited for each other at some distance from the working men, singing and swaying their bodies.

Having gathered and having finished their song they suddenly rushed forward, dropped their things near the other men or near the ovens, went back, gathered again, sang, and went for another load.

3. Young boys, playing around.

4. Women and girls, still absent, collecting tubers and leaves in the gardens. The first woman appeared at about 11.00 a.m.

Wandin, who was to direct the distribution, could be regarded as a separate category. He worked as hard as the other men did and his importance was indicated only by his shouting. For instance, he yelled at the moment when the fire for heating the cooking stones was lit (about 10.45 a.m.). Later he yelled to the women that they should make haste in the gardens. Incidentally he yelled in his excitement: 'our pandanus is big'.

The first stones were brought from the stack to the earth ovens at about 12.40 a.m. The filling of the ovens was done with great excitement. By then large numbers of men were present. About half of them worked in a group; the other half individually. The men working individually had a preference for bringing stones to their own ovens. The group supplied all ovens, consecutively. At this time I noticed that an eleventh oven had been prepared: a number of Ngopare men had joined Penggu.

After the filling of the ovens had been completed people danced. Over an hour elapsed before the ovens were opened. The potatoes and potato leaves were brought around and eaten. The adult men brought the pandanus together putting it on piles, carefully separating their own pandanus from that of other men. They sat down next to their own piles. All people present squatted down to await the distribution of the pandanus. I did not try to count, but estimated there were at least 250 men. The majority of the men had come from other parishes. There were people from outside Mbogoga. At other distributions I had witnessed the owners of the ovens had decided among themselves to what groups and people the products were to be distributed; one of them announced the names, after which each of the owners gave part of what he had brought in to the feast. The donations were handed out by the young men going around in a group and often displaying the products. Sometimes the owners could not reach agreement easily and on a few occasions agreement was not reached at all. Once one of the owners got up, saying: 'If you are not prepared to do it, I will do it on my own'. He took a parcel and took it himself to the recipient. People considered this a very witty move and were quite amused.

I expected that on this occasion Wandin would announce the names of the recipients, after discussion with the owners of the ovens. But rain had started, and a discussion started whether to distribute immediately, or to wait till the weather improved. Wandin did not dominate the discussion at all. He was standing, looking rather confused while the other men were criticising each other's proposals. At this moment Komak intervened: Komak is a big man but he does not have a very

distinguished place among them. He appears to be somewhat older than Wandin. They refer to each other as 'ore'. Komak told the other men to stop, and told Wandin to come and get a few pieces of pandanus: 'Here it is. Go and give it to XX'. Wandin did so. Like the incident at the sugar cane distribution, this too suggested to me that Wandin was not very powerful. But Komak stressed another point later when he discussed these events: 'Wandin had to distribute, because he used to perform *amulok kunik*. Therefore I told him to go'. Although he, Komak, had been the most powerful of the men present, in that he had forced through an immediate distribution, he simultaneously had acknowledged Wandin's superiority.

During the feast in the upper reaches of the Swart the names of the recipients were not called out. Each couple had its own pile of pandanus nuts. Husband and wife took from it so that men and women were walking around in all directions distributing from the piles, making a seemingly chaotic scene.

After Komak's intervention the distribution developed as I had expected. First pandanus was given to groups of men. I could not ascertain whether these groups represented whole parishes, or only parts. Afterwards the women who had steamed the pandanus were presented with some. Finally some was presented to 13 men individually. At least eight of these did not live in Mbogoga. After the distribution had been finished Wandin made a speech stressing that people should not kill each other, that they are all one and the same.

After the speech the feast was over. The women left to prepare the afternoon meal, and many men went away carrying the pandanus with them. A number of young men resumed dancing, other men squatted down near the remnants of the stack. When asked why they were given pandanus, all men said that it was a payment for the things they had brought with them when they came in the morning, e.g. the wooden tongs or the grasses. At that time nobody mentioned the distributions at the preceding or following feasts.

The proceedings of this feast show clearly the autonomy of the individual adults: all men were free to participate or not to participate. The Ngopare men came on their own initiative, the other men had not known beforehand that they would come. All men enjoyed the occasion, probably because by participating they could demonstrate their positions as independent and equal men. Jiwaru was angry that he could not participate.

I did not see Wandin give instructions: all men knew how to proceed. Everybody knew the order and the approximate time at which important events, for example the lighting of the firewood of the stack, had to happen. When the routine was broken, as occurred because of the rain just before the distribution, disagreement arose. The men could in-

fluence the course of events, so were not powerless. Komak did; and it was said that the owners of the ovens could refrain, if they wished, from giving pandanus parcels to a particular recipient. However I did not notice this happening. Yet people had to concede that Wandin was in the central position, and was clearly more important than all the others. Later the feast was referred to as either Penggu's or Wandin's pandanus feast.

*c. Other, extraordinary events.*

After raids and battles and large scale harvest feasts, this is the third and last category of events at which the special position of the big men becomes apparent. Of this category I will mention only the admittance of Ngopare in Wanggulam and the weapon burning at Mbogondini. Probably there have been other comparable events, e.g. the first burning at Mbogondini, but the other two were the only ones which cropped up in discussions. On both occasions Wandin had a special role comparable to the role of the big men during either the raids and battles and their preparations or the large harvest feasts.

Wanggulam always mentioned specifically that the Ngopare asked Wandin whether they could settle in Wanggulam. Wandin's role in the previous history of the case has been discussed (see p. 79). People denied that the other Wanggulam had made objections or had disagreed with Wandin, so that it seems that he did not overrule a dissident faction of the parish.

At the other event, the burning, all Wanggulam seemed to agree upon the desirability of going to Mbogondini and burning the weapons. Here too, the people were anxious to know whether all men would join (see p. 59), so that it seems they were free to come or not. In the discussions immediately preceding the burnings Wandin took an active part. He stressed that the Wanggulam did not have treacherous intentions and to prove his point he destroyed a spear in public. He led the Wanggulam when they rushed off to throw their weapons on a heap. Later he said that he had expected that the other groups would follow, because it would have been 'bad' to retain the weapons. As Wanggulam often exerted themselves to show me their negative attitude towards their traditional culture I doubt whether this was the only reason.

With events of lesser importance (less serious conflicts or small scale feasts and parties) the position of the big men is even less promi-

ment. I give illustrations with the next two cases. Battles, which were referred to above, occur mainly in conflicts resulting from killings or wife stealings. Other transgressions lead to less serious quarrels.

#### CASE 5, WANDIN VERSUS MBABUAREK

Wandin and Mbabuarek got on bad terms after Mbabuarek's dog had disappeared. The latter suspected that it had been killed by Wandin's dog, a suspicion which afterwards turned out to be unfounded. Mbabuarek lived at that time near A (see map V), in the same hamlet where Ngabengga and Erimawe were living. Other inhabitants were two young men, Taukanet, Ngabengga's —B and Wuran, Mbabuarek's —B. Mbabuarek lived in this hamlet until during my stay when he moved to the south bank of the Kurip (see Case 15). Taukanet and Wuran had moved elsewhere already before my arrival in Wanggulam. Wandin's hamlet was about 450 yards downhill, near B. To retaliate for the dog, Erimawe and the two other young men decided to steal a pandanus fruit growing near Wandin's hamlet. Wandin had erected a spirit pole next to the tree on which the fruit was growing and every now and then he came to see whether it was ripe.

One evening the young men went to steal the fruit. Wandin did not notice. Together with Mbabuarek they steamed and ate it in their garden near the Luaga (near C). After Wandin had noticed the theft, he went through the whole of Wanggulam looking for the traces of a pandanus meal, the fruit pips. The fruits were out of season and when he found pips in Mbabuarek's garden he guessed who the thieves were. He did not take further action until sometime later when Mbabuarek and the young men came downhill to find a good lookout to observe the transfer of compensation which was to occur at the other side of the Kurip. They came close to Wandin's hamlet. He saw them and attacked; a brawl started, Wuran fought Wandin and he still likes to recall how he almost broke the latter's wrist. The fight came to an end when Mbabuarek promised to pay a few cowrie shells as compensation.

The important point of this case is that people do not eschew touching the property of big men, and do get into fights with them. Discussing whether to fight a big man or not people are reputed to say: 'You don't suppose the sky will come down over this, do you? Let us go.' This indicates that the force a big man has at his disposal is not much greater than the force lesser men have. That Wandin did not attack immediately after he had discovered who had stolen his pandanus is probably due to the relative unimportance of one pandanus fruit. In the next case more highly valued property was at stake, and the reaction was more violent.

## CASE 6, WOGOGI'S DOG

In February 1962, three young men, two Karoba II men and their classificatory sister's son, killed and ate Wogogi's dog, after the pig's fat they had put in their house (see map V, near D) had disappeared. They assumed that the dog had eaten it, and so killed the animal. The next morning Wogogi, a big man, who lives about 400 yards uphill (near E), went downhill and set fire to a small hamlet (near F). Its former inhabitants had left it a few months ago, and settled in the hamlet near G, where one of the youths had been living until recently. The house of the hamlet burned down together with a number of banana trees in the surrounding garden. Wogogi seemed further to prepare for a bow and arrow fight. Awiambaga, of Karoba I, also a young man, who was living in the hamlet mentioned earlier near G, but who was visiting his elder brother in a hamlet close to Wogogi's, went downhill to warn his peers. He collected from them thirty odd cowrie shells, which he gave to Wogogi. When this amount did not seem to satisfy the latter, Awiambaga again went downhill and collected another thirty shells. These at last satisfied Wogogi, and he did not take further action.

In this case Wogogi took action by himself. He was not supported by his brother and two classificatory brothers although these men all lived close by and were on good terms with him.

The following case indicates also that big men are able to force their will upon others because of their superior fighting ability. At the same time the events of the case show the limitations of such power.

## CASE 7, MBILUMU TRIES TO ABDUCT MBUKMBA

The case took place in the course of my field work but I myself did not observe the events. I was told by three young Penggu men, Wuran, Ikwenggorok and Ngunugago.

At the end of an outdoor meal offered by the organiser of a work party, Mbilumu, a Penggu man, tried to abduct Mbukbarenggeonugwe (hereafter called Mbukmba), a Ngopare girl. Abductions are unusual among the Wanggulam. Two occurred during my stay and in neither case did it result in a lasting union. Mbilumu was unmarried, although he was about 25, an age by which most men are already married. He was living with a MKB, a Karoba, having left his agnatic relatives as a result of a fight (see Case 6). A peer, a Karoba man, helped him to abduct the girl just after she had left the eating ground to go home. Although she violently resisted, the men succeeded in carrying her off. Mbilumu went with her to one of the westernmost hamlets in Nogombumbu where his FBD and her husband lived.

Before she was carried off, Mbukmba had had a chance to yell:

'I want Ogolunggen as my husband'. This was a man she had earlier refused to marry (see case 9, p. 102). He was also a Penggu and belonged to the same sub-section as Mbilumu. The next morning, when Ogolunggen's father, Ngwembanik, heard that Mbilumu was in Nogombumbu, he went there together with a married daughter. They noticed Mbukmba digging sweet potatoes in a swidden while Mbilumu guarded her from some distance. Ngwembanik and his daughter managed to get close to Mbukmba and Ngwembanik said to her: 'What do you want, Mbukmba: to go away with my daughter, or to stay with Mbilumu?'. Mbukmba preferred to go with Ngwembanik's daughter, seemingly because she agreed to a marriage with Ogolunggen. When Mbilumu noticed what was happening and tried to prevent the two women from going away, Ngwembanik stood in the way and invited Mbilumu to fight him if he dared. Since Ngwembanik is a renowned fighter (see Case 20, p. 160), Mbilumu retired, and the women were able to escape.

However, Mbukmba's wish to marry Ogolunggen had been a pretence. When she came in Ngwembanik's hamlet, she made clear that she did not want to marry him and Ngwembanik could only let her return to her own hamlet. The young men who told me about the course of events said that Mbilumu had handled the matter wrongly: he should have gone much farther away to relatives in a foreign parish, at a few days' distance. Among these foreigners Ngwembanik would not have dared to go to get Mbukmba and she would not have dared to run away. Mbilumu should have stayed there until Mbukmba had become pregnant, since once they are pregnant, Wanggulam women rarely break their marriages. The three men said also that Ngwembanik could rightfully oppose a marriage between Mbilumu and Mbukmba, since his son and Mbilumu belonged to the same sub-section. After she had refused Ogolunggen, Mbukmba should not marry another member of his sub-section. I attribute this to the fact that male members of a sub-section often live in the same or closely adjacent hamlets so that the rejected suitor is likely to meet regularly his would-be bride and her husband. Since their mutual relationship is strained, their meeting would result in awkward and tense situations. However, I did not manage to elicit this or any other rationale for the prohibition. Nor do I know if Ngwembanik used it as a pretext in trying to bring about his son's marriage. Ogolunggen was disfavoured by Wanggulam girls, reputedly because of his heavy build, and Mbukmba was already the fourth girl to refuse him. A couple of months after the events mentioned in this case had happened, Ogolunggen suddenly left Wanggulam and, so I was told, went to Panaga in the Swart Valley, vexed because he could not get married. It is likely that his father was also concerned about his son remaining unmarried and that his concern led him to get Mbukmba out of the hands of Mbilumu.

The case shows also the freedom Wanggulam women enjoy. Mbukmba's father had died and Lembiagop, her elder brother, tried to arrange her marriage. Both he and Ngwembanik wanted her to

marry Ogolunggen, who also was willing to marry her. However, they could not force her to marry him. Ogolunggen himself might have tried to abduct her and to take her to Panaga, three days' travel away. However, I do not know whether he contemplated such an action and, if so, why he refrained from doing so. The ceremonies for the short-lived marriage between Mbukmba and Ogolunggen had taken place in February 1961 (see Case 9, pp. 102 ff.) and the abduction occurred in March 1962. When I left the Wanggulam in August 1962, Mbukmba was still not married. She was on bad terms with her brother — who needed her bride price to pay for his own wife (see Case 9, p. 104) — and she lived part of the time with her classificatory brothers, in a hamlet not on Wanggulam territory. One of them told me that Lembiagop had offered her several other husbands but that she had refused them also. He said that her stubborn refusals caused concern and that they, her classificatory brothers, did not know what to do about it.

There are no cases indicating that big men had groups of partisans on whom they could rely and who were prepared to follow them when summoned. Men who group to wage a raid unite for that particular purpose. They do not form a regular gang. An example of such a group is the one which tried to capture Jiwaru's wife (see p. 99). The high residential mobility hampers lasting associations: the men in the group which stole Wandin's pandanus in about 1958 did not live together in the same hamlet in the beginning of 1960. Wuran had moved to the hamlet of another elder brother. Taukanet had become a mission boy. Later during that year Mbabuarek moved to the other bank of the Kurip (Case 15, p. 141). Interaction between the men had decreased greatly. Contacts between the men who killed Wogogi's dog decreased a few months later as a result of the revival of the religious movement: one of the three moved to the hamlet of his ZH.

In these cases the big men themselves were parties to the disputes; the question remains whether they have a say in conflicts between others, e.g. whether they can act as mediators, as occurs in other Highlands societies.

Among the Kapauku (Pospisil; 1958, p. 255), and the Kuma (Reay; 1959, p. 125) public meetings or 'courts' are held to settle disputes. During these, leaders have an important role. Among the Huli prominent men may be 'called on to advise in quarrels' (Glasse; 1959, p. 282). Below I mention that meetings organised by the missionaries provided an opportunity for the discussion of interparish disputes. I did not hear about any traditional institution to settle either intra- or inter-parish quarrels.

## CASE 8, WANGGULAM VERSUS NGIGAMULI

This case happened about 20-25 years ago. The Ngigamuli are a section from a neighbouring parish. They had to flee their territory after they got into trouble over a sorcery case. They asked the Karoba for shelter and the Karoba agreed. Arrived on Wanggulam territory the Ngigamuli began quarreling among themselves: they could not decide who were to use the timber of a deserted house to build themselves a house. A bow and arrow fight developed and Tiragop, a very big man ('compared with him, Wandin is small'), tried to separate the fighters. He was wounded and died shortly afterwards. A very tense situation arose, and the Wanggulam gathered in order to fight the Ngigamuli. During the gathering Wurirarange, a big man, who had been living together with Tiragop, the SS of a female patrilineal relative of Wurirarange's, advised the men not to fight lest other people be killed. They should ask, he said, for compensation. His words had effect; it did not come to a fight. When Wurirarange returned home Tiragop's old father turned away from him and said: 'You should have killed a Ngigamuli. Why did you urge peace? I do not want to live with you any longer'. Wurirarange felt ashamed and thereupon gathered a number of men. A fight developed and three Ngigamuli were killed. They had to flee again.

The next case is a long series of quarrels between a number of Wanggulam. In the course of the quarrels only slight attempts at intervention are made.

## CASE 9, JIWARU

During the first half of 1960 the households of Jiwaru and Arigunik lived together in one hamlet. At the end of May the Wanggulam built me a house in this hamlet. As they thought that I wanted to live alone, just as other Europeans did, both Jiwaru and Arigunik moved. Jiwaru went to Ngabengga's hamlet, about 200 yards away; Arigunik started to build a new hamlet, about 200 yards farther away in the same direction. In between the first two hamlets is a gently sloping tract, covered with grass. The hamlets are visible from each other. After it had become clear that I did not want to live alone, Jiwaru returned to his former place; Arigunik, however, stayed in his newly built hamlet. As he had not yet built a men's house, he and his brother slept in Ngabengga's men's house.

Jiwaru is a Penggu, Arigunik is Jiwaru's ZS (see Figure 7), his wife Namungwe is also Penggu. Until May 1960 Jiwaru's hamlet had three women's houses: one for each of his wives and one for Namungwe, her children, and Arigunik's younger sisters. Arigunik's father, Manggumbini, lived in Ngabengga's hamlet. He had come to

Wanggulam after his wife had died and originally he had lived with Jiwaru and Arigunik, but he had left after a quarrel with Jiwaru. This concerned the cremation payment for Manggumbini's deceased son. Although he had already received a pig from this payment, Jiwaru wanted to get an additional *jao* and he kept asking for it.

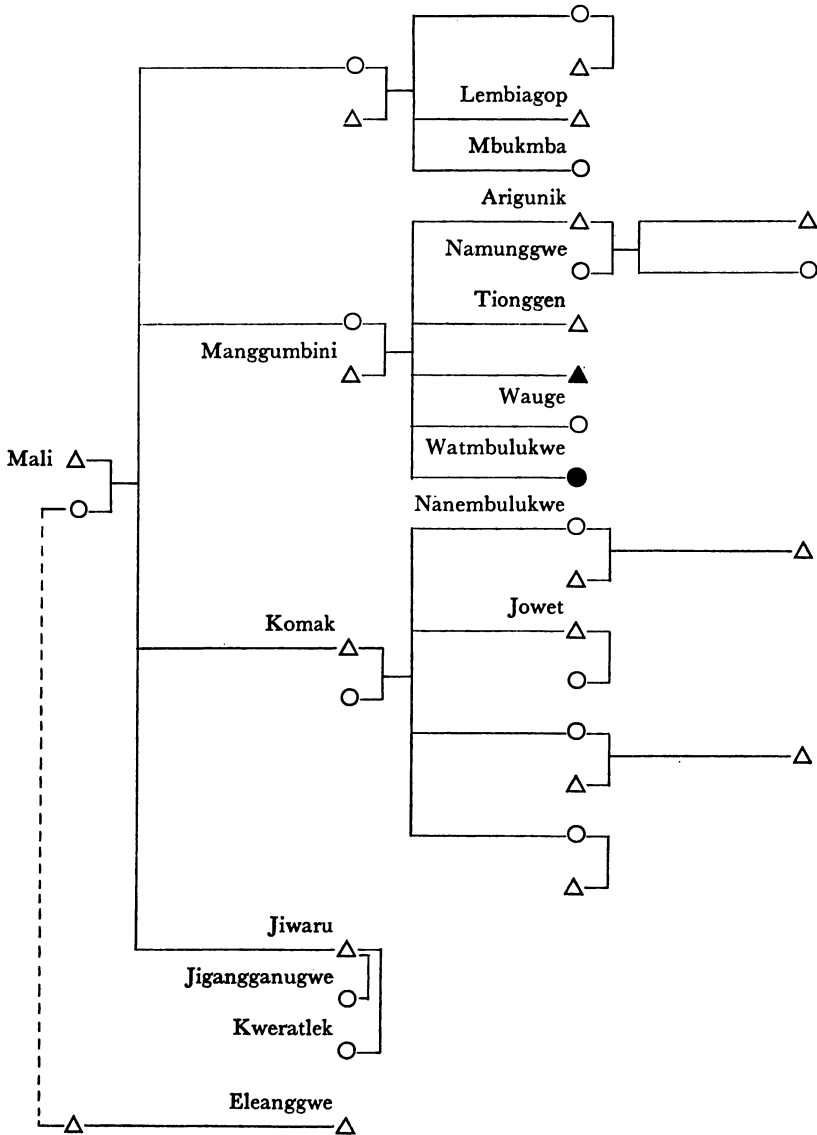

FIGURE 7: JIWARU'S CLOSEST RELATIVES

Mangumbini did not want to give him this *jao* and finally moved away to Ngabengga's hamlet. Jiwaru had the reputation of being a quarrelsome man, intent upon giving the impression that he was an important big man. Many did not like him, and they did not pity him for his sterility. During the middle of 1960 there were several signs of animosity between the two men and between their wives. On 21 September the men had an open quarrel. Arigunik had come to his former hamlet to dig cassava. Jiwaru saw him digging, and started to shout angrily that Arigunik was digging cassava he — Jiwaru — had planted. Arigunik tried to explain that it was his own cassava; he said that he had planted it, and he started to trace the boundary between his and Jiwaru's cassava. The two men could not convince each other and went on quarrelling for some time; in the end Arigunik left with a number of cassava tubers. A number of men were present, but nobody tried to intervene. One of them told me: 'MB and ZS are quarrelling'. This seemed to amuse him although I heard people often maintain that quarrels and fights between MB and ZS were highly objectionable.

The next day a number of women had words over the methods some of them reputedly had used to try to prevent others from selling me vegetables. Above all Arigunik's wife, Namunggwé, was accused of having tried to get more than a fair share of the salt I used to pay for vegetables. The noise of the quarrel reached the men's houses of Arigunik and Jiwaru, and soon there was a quarrel between the two men, each standing in the yard of his hamlet. Jiwaru in particular flared up, shouting at the top of his voice, simply yelling by fits and starts. It seemed to me that, either on purpose or involuntarily, he was showing off. Their shouting made it impossible for me to understand what the men said. Afterwards I was fobbed off with the remark that Jiwaru was a nasty trouble-maker. Again, nobody tried to intervene. At last Jiwaru ran to his men's house, returned with a large club, left the hamlet yard and went to Arigunik's hamlet. Women started to shriek, Arigunik armed himself also and went to meet Jiwaru. Both halted when they were at about twenty yards distance and started a new discussion. Again I could not understand what was being said. Arigunik's father and brother, armed with clubs, had joined Arigunik. The father entered the discussion. After a few minutes of talking Jiwaru returned to his hamlet where, however, he again started to yell and to shout. For a while it looked as if it would yet come to a fight. In the afternoon there was another outburst. Jiwaru was walking up and down in the hamlet garden carrying his steel axe in his hands. He was frantic, shouting again and again: 'Go away, go away'. Arigunik was in his sweet potato garden which adjoined the hamlet (so that the high hamlet fence separated the two men). He behaved with great control, sauntering around with his axe on his shoulder, as if to have a look at his crop. His father and brother, armed with their clubs, had entered Jiwaru's hamlet, but seeing him in this state of mind they retired, calling Arigunik to come

with them. While they were in the yards of their hamlets both parties went on abusing each other for some time.

Some days later Arigunik came to my house after Jiwaru had left, announcing that he would not come again and asking me to take care of his plot in the hamlet garden, which was near my own house. He went, leaving his wife's father and another Penggu man. They dug a number of cassava tubers, the stems of which Arigunik had marked with small pieces of bark. They were dangerously close to the cassava disputed on the 21st. The men did not mention this quarrel at all.

Jiwaru did not have another outburst. On the morning of the 30th Arigunik and his father visited me again. Jiwaru was absent. Suddenly people came in to say that Watmbulukwe, Arigunik's youngest sister, a girl of about ten years, had 'gone to the river', meaning that she had committed suicide by drowning herself. We left immediately. The rumour turned out to be true: the girl had gone to the Luaga and had thrown herself into the river. A man had succeeded in hauling her out, downstream, from the Kurip. She was dead. The corpse was brought to Arigunik's hamlet where it was cremated the next day.

Before a deceased person is cremated, the cremation payment is made. It consists of the same objects as constitute a wedding payment (cowrie shells, shell bands, *jao*, and pigs) but it is much smaller. It is paid primarily to the section of the deceased's mother. In this instance, the large items of the payment, pigs, *jao* and shell bands, were contributed by patrilineal relatives of the deceased: Arigunik himself, his K+Z, Ngerenggaligwe, and a Penggu, a FKZS.

These valuables were distributed to matrilineal relatives:

Nanembulukwe (Watmbulukwe's M+BD), one pig;

Nginarek (Watmbulukwe's MMZS), one *jao*;

Komak and Lembiagop (Watmbulukwe's M+B and her M+ZS respectively), two *jao* and three shell bands.

The men who hauled the girl out of the water and carried her to the hamlet were given a number of odd shells out of the payment. Nanembulukwe was given a pig because she had taken the corpse in her arms while the death chants were sung in the night preceding the cremation. Nginarek was given a *jao*, 'because he is the girl's MB'. I do not know whether there was any other reason for this. Komak and Lembiagop were given valuables together because they watched over the cremation. Jiwaru did not receive anything. Later Nginarek told me that Arigunik afterwards gave one shell band to Perenatmendek, the former's +B and Ngerenggaligwe's husband (such transfers in arrear are not unusual, see p. 34).

The next day, 2 October, Arigunik went around with his bow and arrows. Within two days he managed to shoot three birds, a strong indication that the misfortune was induced by *mum* (see p. 54). Together with his father and brother, and occasionally with other relatives, he steamed grass once every day during the whole of the week from 1 October. On the last day the girl had been hauled out of the water. During the first half of the next week nothing happened. On

Thursday 13 October, one of Jiwaru's wives, Kweratlek, went to Mbogondini 'to see her parents'. Wuran, my houseboy, said that she had fled. He asserted that Kweratlek had worked *mum* against Watmbulukwe, since Arigunik had failed to pay her in return for the piglet she had contributed to the cremation payment for a younger brother of Arigunik.

Jiwaru left on Friday to fetch his wife from Mbogondini. He did not return for the night. The next morning at about 6.30 a.m. Arigunik tried to capture Jiwaru's other wife, Jigangganugwe. He was accompanied by his brother, Tionggen, his MZS, Lembiagop, and three FKZS's, one of whom lived outside Wanggulam. His attempt was unsuccessful, as Jigangganugwe had fled to her agnates' hamlet. At that time many people seemed to be convinced that the two co-wives had worked *mum* against the girl, and that Jiwaru had induced them to do so. The three were openly condemned. The same afternoon Jiwaru returned with his two wives; he was armed with bow and arrows. Some time later he was joined by Wandin, also a Penggu, and slightly older than Jiwaru, and by a KBS. The two men said that they had come to support Jiwaru. In the evening Wandin went to the men's house of Ngabengga's hamlet where Arigunik stayed. After he had returned he said to me that he had told Arigunik not to try and fight Jiwaru. The latter left with his wives for Mbogondini early the next morning.

During Jiwaru's absence, Arigunik disturbed the thatched grass on the roof of Jigangganugwe's house. Wandin returned to Jiwaru's hamlet and planted a number of tree branches on the path leading towards the women's houses. They did not form a solid fence, but nobody crossed them for fear that Wandin would give him a beating. Part of the day Ngunduarek (a Karoba, and Jiwaru's FMBSS) kept watch. He had told Jiwaru that he did not believe Arigunik's accusations and that he would kill Arigunik if the latter killed Jiwaru. During the watch Arigunik entered the hamlet and told Ngunduarek what a bad man Jiwaru really was. Ngunduarek listened and did not show that he did not agree.

This attitude was very characteristic. The Wanggulam did not split into two camps, one pro-Jiwaru, the other pro-Arigunik. Nevertheless people professed to have very definite ideas about the situation. Most people I heard said Jiwaru and his wives had caused the girl's death, but they remained on speaking terms with both Jiwaru and Arigunik. They did not tell either of the men that they did not believe him.

Jiwaru returned on Monday, two days after he had left. On the same day Arigunik dismantled his house and started to build a house in his WF's hamlet. He got the help of the latter's co-residents, a number of Ngopare men who were Arigunik's MKZS's. When he heard that Jiwaru had returned he took his bow and arrows, went to Jiwaru's hamlet, and had a discussion with him. It did not come to a fight. Arigunik was backed by his brother, his wife's father, and a number of Ngopare. The shouting was audible at a great distance, but only

Komak, Jiwaru's +B, made a feeble effort to intervene by saying that the afternoon meal was almost cooked and inviting the quarrellers to come to eat. This invitation was met with sneers. Later Komak joined Arigunik and his companions. He said that a MB should not behave in this way towards his ZS. The others abused Jiwaru freely, frequently saying that he was a satan (*ap taitan*, a word introduced by the missionaries).

After I had returned to Jiwaru's hamlet, Jiwaru told me that he was in the right; he had not told his wives to work *mum*, and they had not worked *mum* on their own initiative ('How many days steaming had not been required to find out that they had done it?'). Arigunik was very ungrateful to him, although he — Jiwaru — had admitted him in his own hamlet. After I had come Arigunik should have returned to the hamlet, just as he — Jiwaru — had done. Finally Jiwaru accused Arigunik of having stolen a knife. Now he wanted to cut the ears of Jiwaru's wives, which was an outrage.

The next day it came to a fight. Arigunik appeared at about 11.00 a.m. For some time Jiwaru stayed in his men's house. There was great unrest: Komak, armed with bows and arrows, tried to get me away from the scene. Ikwenggorok, my then houseboy, went to fetch his bow and arrows. In order to do so he had to pass Arigunik and his group. They let him. Suddenly Jiwaru appeared from the men's house, left the hamlet, and went to the small plateau between the two hamlets. He was followed by Ikwenggorok and another man who had been with him for a few weeks, a visitor from the Swart Valley. Arigunik was supported by his brother and by Lembiagop; his wife's father and the Ngopare men, though armed, stayed behind. Jiwaru and Arigunik shot several times at each other, from a distance of about 25 yards. Both missed and Arigunik retreated, followed by Jiwaru. When he was close to Arigunik's former men's house, Komak intervened. From a great distance he shot an arrow at Jiwaru. The latter, surprised, retreated towards his hamlet. The parties resumed abusing one another. The shooting was repeated by Lembiagop and Jiwaru; again both missed. The women got quite active now: Kweratlek threw a number of stones at the opponents. At this stage people intervened: Arigunik and Lembiagop were urged back by a KB of Arigunik's WF. One of the men in the other group took Kweratlek by the arm. There followed an argument between the brothers, Komak and Jiwaru, Komak repeating again and again that one does not shoot one's ZS.

In the afternoon there was another quarrel: Arigunik's wife was chased by Jiwaru's wives when she came to dig potatoes in the garden close to her former hamlet. She returned after some time, we talked, and my houseboy told her how he had supported Jiwaru in the fight against her husband.

Jiwaru had a number of visitors during the afternoon. One of them was Ngunduarek. He said that it was now clear that Arigunik had invented the charge, as he had not succeeded in killing Jiwaru. The events were discussed over and over again, Jiwaru playing the hero.

Kweratlek, his wife, said smiling: 'And it was with his ZS'. The discussions alternated with prayers and the telling of Bible stories. The missionaries had recommended that, when a number of people were together, everybody should in turn try to tell a Bible story, so that others would be able to help and correct. During the next day everyday life was seemingly resumed. Jiwaru, however, left his hamlet rarely, allegedly because he was afraid that during his absence Arigunik would come and set fire to it.

After the shooting incident the Wanggulam again did not divide into factions, one pro-Jiwaru, the other pro-Arigunik. Arigunik, his father and his brother, and Komak and Lembiagop avoided seeing Jiwaru, and vice versa, but Komak's wife and children had many contacts with Jiwaru and his wives, whereas Jiwaru's wives did not avoid Komak. A few days after the fight I went to see Arigunik. Ikwenggorok, the houseboy, went with me. He said that Arigunik would not be angry with him, although he had shielded Jiwaru, because he — Ikwenggorok — had fought 'for nothing'. The matter would have been different if Jiwaru had killed Arigunik. This would have caused a big fight. Ikwenggorok said that he had joined Jiwaru because he worked for me and I was Jiwaru's co-resident.

Komak and Jiwaru had had a quarrel before. This had happened a number of years before my stay among the Wanggulam. The classificatory brothers of Komak's second wife had urged her to come back after both her children had died. The woman did return and Komak fought her classificatory brothers in a vain attempt to get her back. He was supported by Jiwaru and by his father who was wounded during the fight. Some time later Jiwaru tried to get compensation from Komak because his father had been injured during a raid organised for Komak's sake. Jiwaru said that the grief he had suffered on account of his father's wounds had been caused by Komak. Komak said that Jiwaru's father was also his own father, so that he — Komak — had suffered as much damage as Jiwaru. He refused to pay. Jiwaru kept asking however, whereupon Komak left him.

During these quarrels intervention occurred sparingly. There was no attempt by anybody, not even a big man, to act as the holder of a superordinate or impartial office. Wandin did not say that he had intervened; he said that he had supported one of the parties. He did not retaliate after Arigunik had damaged Jigangganugwe's house. He only discouraged Arigunik from further action by blocking the path. Nevertheless his actions did not prevent Arigunik from fighting Jiwaru a few days later. Komak also was not dispassionate; he tried to prevent the fight because he backed Arigunik.

During the next few months Wandin seemed to back Arigunik's case. In the beginning of December 1960 he refused to give Jiwaru a number of pandanus fruits, so that the latter could not participate in a large harvest feast (discussed in Cases 4, pp. 86 ff., and 10, pp. 122 ff.). Before, Wandin had said that he did not like Arigunik because the latter had cheated him with pork. Later he said that Jiwaru was a

troublemaker. The two men did not avoid each other: Wandin still visited Jiwaru occasionally. It was also said that Arigunik intended to move to a new hamlet a number of Penggu men were building; Wandin was among these men. Jiwaru got very annoyed with them and scolded the wife of one of the men when she came to sell me vegetables. Still later, he accused Arigunik's wife of intending to kill him by working *mum*. He accused her of this in public during a harvest feast held on 21 January 1961. These disputes only added to his reputation as a troublemaker.

In the meantime the relationship between Komak and Arigunik had cooled down a bit after Komak had discovered that one of the banana stocks ripening in the garden close to his hamlet had disappeared. This happened on 2 January 1961. The greater part of the garden was used by Arigunik and his wife for cultivating sweet potatoes. Komak suspected that Arigunik had stolen the stock of bananas and he complained loudly about it. His complaints were overheard by Jiwaru working in his own hamlet garden and he joined Komak in decrying Arigunik. This was the first time I noticed Komak and Jiwaru speaking to one another after their fight. On other occasions when I had seen them together, they ignored each other.

At the beginning of February 1961 the quarrels took a new turn with the marriage ceremonies for Waugwe, Arigunik's sister. Jiwaru was her MB and part of the *uak* had to be given to him. The ceremonies for Waugwe's marriage were combined with those for her M+ZD, Lembiagop's younger sister Mbukmba. The two girls lived in the same hamlet. The *uak* for Waugwe consisted of eight shell bands and 21 *jao*, Mbukmba's *uak* of eleven shell bands and 18 *jao*. The total amount of valuables laid down during the distributions was:

for Waugwe, 12 *jao* and four bands;  
for Mbukmba, 13 *jao* and six bands.

People said that beforehand Lembiagop had paid Arigunik for what

	Waugwe		Mbukmba	
	<i>jao</i>	s.b.	<i>jao</i>	s.b.
a. total amount of valuables during distribution	12	4	13	6
b. contributions by Arigunik and his —B to Mbukmba's <i>uak</i>			2	3
c. contributions by Lembiagop to Waugwe's <i>uak</i>	1	1		
d. totals	13	5	15	9
e. totals of <i>uak</i>	21	8	18	11

TABLE 11: *UAK* FOR WAUGWE AND MBUKMBA

the latter had contributed to the *uak* for Mbukmba, his MZD, and that Arigunik had repaid Lembiagop for the latter's contribution to the *uak* for Waugwe, Lembiagop's MZD. The amounts Arigunik and Lembiagop had contributed to the two *uak*, however, did not completely cover the difference (see Table 11, d and e). The distribution was sharply criticised afterwards. The argument was that Arigunik and Lembiagop had given each other too much, so that there had not been enough left for their mother's section.

On the morning of the distribution Eleanggwe had made known that he wanted to be paid for the pig his father had contributed to the *uak* of the MM of the girls. Eleanggwe is a Mabu, a KBS of the MM of the girls. This claim was discussed in the men's house before the distribution started. Komak especially opposed it. I could not follow the conversation but later I heard that, if Eleanggwe had spoken the truth, he should have been paid. But people added that he had lied and that he had been repaid during the distribution of the *uak* for the mothers of the girls. In the course of the distribution Eleanggwe was given one shell band, from Waugwe's *uak*. Komak was given two *jao*, also from Waugwe's *uak*, and Jiwaru one shell band and two *jao*, from Mbukmba's *uak*. Komak's married son Jowet got two *jao*, from Mbukmba's *uak* and his eldest married daughter Nanembulukwe one shell band from Mbukmba's *uak*.

Eleanggwe, Jiwaru and Komak all disapproved of the distribution. At the actual distribution Komak had been present. He had been less friendly with Arigunik than usual, but he had not protested against the course of events. I attributed his displeasure to his suspicions that Arigunik had stolen the stock of bananas from his garden, about one month before. Eleanggwe himself had not been present. His daughter, about twelve years of age, received the shell band. She had lingered some time before going to take the band, an indication of discontent foreshadowing the events to come. Jiwaru had not been present either. In the afternoon he was brought his share. He did not show signs of discontent.

Early the next morning Jiwaru cursed one of the girls (see p. 56). He got into a frenzy, ran around the yard of the hamlet, telling God how seriously he had been wronged. Finally he disturbed his father's grave, and said that he wished the girl to become barren. Some time later Komak came and held a whispering speech looking at his father's ashes. Later I was told that he had cursed the other girl. It seemed to me that Jiwaru was showing off. He is a very able impostor, and the sincerity of his conversion to Christianity is very doubtful. Earlier in the morning I had heard Jiwaru talking with another man. I thought I recognised Komak's voice. Jiwaru was told that he should curse Waugwe and then should ask to be given a pig. Komak denied later to have spoken to Jiwaru, and said it had been Eleanggwe. The latter had also cursed the girls. He had brushed ashes on the hearth-poles of his house. After Mbukmba's husband had given him a pig, he annulled his actions.

People seemed to believe that the girls would not bear children. The mother of Waugwe's husband said: 'We paid such a large amount as bride price and now she is barren'.

It often happens that people assert that a distribution is incorrect, but they usually do not complain so loudly, and cursing a girl in an overt way is even less frequent. People say that most curses are enunciated in secret. Also, people usually wait much longer before proceeding to a curse, since they expect that the distributor will pay them a second time to prevent them from cursing the girl.

These events occurred at the end of the first part of my fieldwork, in the beginning of February 1961. When I returned to the field, at the end of that year, Jiwaru was living on the government station. His wife, Kweratlek, told me that they had left Wanggulam because of the fight with Arigunik, but others denied this, saying that Jiwaru's motive had been his desire to earn a great deal of shells. Both Waugwe and Mbukmba had run away from their husbands. People attributed this to two motives: the curses, and their dislike for their husbands.

During my absence troubles had arisen between Jiwaru and Erimawe after the latter had committed adultery with Kweratlek. Erimawe is a ZS of Mbobigi. He lives in the hamlet of Ngabengga, the second husband of his mother, Mbobigi's sister. Bot Mbobigi and his son, Ikwenggorok, contributed to the compensation paid by Erimawe. But Jiwaru kept asking for more and people were afraid that he would try to induce the police to go and arrest a few Wanggulam. His reputation had become worse, and declined still more when he tried to marry off Wanggulam girls to coastal Papuans employed at the government station. During the marriage negotiations he asked for a large bride price, pretending to be the father or the closest relative of the girl. His first attempt was successful. Waugwe had left her brother, Arigunik, for Jiwaru since the former was angry with her after she had left her husband. Jiwaru advised her to marry a coastal Papuan. She followed the advice and the new husband paid a large amount of steel axes and bush knives to Jiwaru, who pretended to be her father. Some time later Anarak, a classificatory elder brother of Waugwe's former husband, told me that Arigunik had failed to repay him Waugwe's bride price. Arigunik in his turn maintained that he had not been able to repay since Jiwaru had kept most of the bride price to himself. Against this Jiwaru maintained that he had handed over the bride price to Arigunik. Although the general presumption was that Jiwaru was lying, nobody seemed to know precisely what had happened. I got the impression that such situations occur quite often: people know that discord is developing but they are ignorant about all the ins and outs of the case. Often they remain ignorant about the facts since among the Wanggulam public hearings of trouble cases are not held.

Later Jiwaru tried to marry off three other Wanggulam girls, though each time without success. One of these girls was Mbukmba, Jiwaru's ZD. Ikwenggorok complained to me about this. Mbukmba's +B,

Lembiagop, had recently married Kumu, Ikwenggorok's F—BD, but he had not paid the full bride price so far. He would be able to do this when Mbukmba would marry and he would receive a bride price for her. Ikwenggorok and the other members of his sub-section (see figure 9) became afraid that they would never receive the full bride price if Jiwaru was able to marry her off, receive the price and keep the valuables to himself.

In this way Jiwaru alienated more and more people. They were nevertheless reluctant to go and tell the government officer as they doubted whether he would heed their evidence against Jiwaru, being 'Jiwaru's co-resident'. With the money he earned, Jiwaru married a third wife. She had been married before with a Mbogoga Dani who worked for the government, was punished, and sent to the coast. There were rumours that the government officer disapproved of the marriage and intended to arrest Jiwaru. These rumours developed: every now and then people related that Jiwaru had taken refuge and had gone to the new hamlet Komak was building near the Mbogo. On hearing these rumours, Ngunduarek, who initially had supported Jiwaru, said that he was prepared to kill him.

Both Case 8, Wanggulam versus Ngigamuli, and Case 9, Jiwaru, indicate that big men are largely incapable of intervening in trouble situations:

1. The extent of their power and authority is very small. Big men have no means of force at hand enabling them to impel other men to stop fighting, so intervention is very risky. As in the case of Wandin versus Mbabuarek, the Ngigamuli did not refrain from fighting a big man.

2. There may be other people who are listened to. Wanggulam stressed that both Tiragop and Wurirarangge were big men and said that they tried to influence the course of events because they were big. The case shows that Wurirarangge thought that the father of the killed man had more say in the question whether to fight or not, although Wurirarangge was a big man and the other too old to be big any more. The same situation existed here as existed on the field of battle where — after a killing — the closest relative of the killed took over from the big men the right to decide whether to end the fight or not.

Another instance of action taken by a big man in quarrels between other Wanggulam occurred in Case 9 when Wandin joined Jiwaru during his quarrels with Arigunik (see p. 99). In this case Wandin phrased his behaviour as support for Jiwaru. Perhaps his main intention was not so much to protect Jiwaru as to prevent Arigunik from

starting the fight. If so, the only force Wandin could have applied to prevent a fight was, ultimately, his own capacity as a fighter. When it later actually came to a fight between Jiwaru and Arigunik, Wandin made no effort to prevent it, although rumours about an impending fight had been circulating for days. One of the rare instances of intervention occurred when Mbabuarek was prevented from fighting his WKF (see Case 15, p. 141). Here it might have been relevant — but the Wanggulam did not explicitly say so — that Mbabuarek was armed with bow and arrows, whilst his WKF was unarmed.

In general people are little inclined to intervene and this seems to me to be another consequence of the principle of autonomy: people feel that a quarrel is the affair of the quarrellers so that others have no right to intervene.

Salisbury (1964a) asserts that:

although the indigenous ideology [among the Siane and the Chimbu] was one of democratic equality and competition, the empirical situation at this time was one of serial despotism (1964a, p. 225).

These conclusions are at variance with those reached by most other writers on leadership in the New Guinea Highlands. It seems to me that the above discussion shows that, if serial despotism occurred at all among the Wanggulam, it did not occur during the period 1935-1960. Neither Wandin nor any other big man had despotic control over his co-parishioners.

Salisbury's conclusions are also said not to be applicable to the Mbowamb (Strathern; 1966, p. 363).

Several aspects of the role of big man can be distinguished:

1. His position as an instrument of government, that is to say the extent to which he can impose his will upon others, whether using his power or his authority, and whether the others want to obey or not. This aspect became most clear at the gatherings to decide about war. Even here it seems that people could not be forced to join the fight. Thus the governmental capacities of the big men were severely restricted, but it should be remembered that the decisions taken on these gatherings were of great importance to the Wanggulam, which reflected on the importance of the big men themselves. Also, in a society in which the equality of the adults is stipulated, a slight quantitative difference in status is likely to be perceived qualitatively as a great difference. This holds also with regard to the other aspects of his position.

2. His ability to represent the community to the outside: that is to say the extent to which he can act as spokesman of the community and can announce its decisions. This aspect became apparent during the pandanus feast.

3. His reputation, that is to say the prestige he has gained by being successful in the activities the Mbogoga value highly: fighting and leadership during fights. In this sense the big man is the man 'who did better' than other men. This aspect seems to be most prominent in daily life. The big man's capacities as a fighter and as a leader, and his representative function, become apparent on a limited number of occasions, but the reputation he earns on these occasions stays with him for a longer time.

4. Because of their capacities as leaders and killers, big men have an important role in shaping the relationships of their co-parishioners with other parishes. The big men are the killers and the other people have to adjust their behaviour on account of these killings. Although these may be committed in retaliation, people have to be on their guard against further counter-actions (see p. 133).

Before the arrival of the Europeans and up to 1960 fighting occurred frequently and the power of the big men was manifest. In 1962, during the last part of my stay among the Wanggulam, the outstanding position of the big men declined as a result of the religious movement (see p. 64). It might be supposed that up to 1960 their important role during periods of fighting was retained during times of peace, so that before the pacification their position was more marked. This was always denied by the Wanggulam and their denials seem to be confirmed by other events, for example those of the case Mbabuarek versus Wandin.

Having discussed the position of the big men, I now turn to other forms of leadership among the Wanggulam.

A number of small scale feasts and gatherings may bring a man into a leading position. These occasions are:

- a. work parties;
- b. small scale harvest feasts, organised by one or two men, for example to remunerate the men who supported them in making a garden;
- c. wedding ceremonies;
- d. cremations;
- e. assembling and distributing compensation.

On all these occasions there is one man who is in the central

position: for instance the organiser of the work party, or the provider of the agricultural products, or the father of the bride. These men can be said to be leaders for that particular occasion. The leadership is rotating: here again it is open to almost all men, and not only big men, to organise gatherings of this kind. It rarely occurs that parties and feasts are organised by men who are not yet adult, or by men who are considered to be particularly unimportant, because they are stupid, cowardly or poor. Neither Erimawe, nor Ikwenggorok (see Case 3, p. 83) had organised a working party up till 1962, but another young Wanggulam man, younger than Erimawe, older than Ikwenggorok, and married before the other two, organised a working party when he built a house for his wife.

The actual authority of these temporary leaders, for example the organiser of a working party, is small. His supporters come mainly on their own accord. The organiser invites them early in the morning, going around and visiting a few men's houses saying that he has collected firewood and stones for an earth oven. People find it difficult to refuse the invitation, if they want to avoid bad feelings or cannot find a good excuse, for a refusal might be interpreted as a sign of dislike, and therefore sometimes they join although they do not want to. The organiser is not present at the actual work. Wanggulam consider the meal offered by the organiser the reciprocation of the labour offered by the workers. While the workers render their service, the organiser prepares his: the meal. When noticing the smoke of the fire heating the cooking stones, people comment: 'The smoke of so and so's work'. When the food is cooked, the organiser yells to the workers to come and eat. He makes sure that everybody gets an equal share of the food. If the party is small, he himself brings the food around, if it is big, he supervises the young men who perform this task. In either way he enjoys the situation thoroughly. It is referred to as 'his' work. The organisation of a small scale harvest feast is even more simple than the organisation of a working party: often people find out about it only on account of the smoke of the fire heating the cooking stones. The organisation of a feast or a party with many attendants brings the organiser a great deal of prestige; if he was not a big man before, he is suddenly referred to as one. This prestige does not last long however: after a number of days people have forgotten about it.

The occasions on which a man can get into a central position can be related to a number of qualities the Wanggulam value highly. The importance attached to being organiser of a working party is consistent

with the importance put on industry, on this occasion expressed by the organisation and preparation of a lavish meal (which refers back to an abundant crop, thus to a big garden, and ultimately to the work involved in making the garden). As support is given on a basis of reciprocity, the work is also a demonstration of the support the organiser himself has given on previous parties organised by others, and will give on following parties. The importance of being the organiser of a harvest feast is another means by which a Wanggulam can show his industriousness. In the case of wedding ceremonies there is a connexion with the governmental implications of alliance, to be discussed in the next chapter.

Generally, the significance of being the distributor of a payment, whether a wedding payment or a compensation, lies in the important role the distributor has in decisions about how the payment is to be divided and who are to receive it. Moreover, the distributor is the focal point of a number of exchange relationships. Finally, on all these occasions it is advantageous for the central man if he is able to make a good public appearance.

The discussion so far has concerned people whose reputation is above average. At the lower part of the scale are the 'small men' (see p. 75). These are the men who are *jundurak*. The meaning of this word is close to the meaning of 'obtuse', or 'stupid', but it indicates not only that a man cannot think for himself, and has to be advised, for instance on matters concerning wedding payments, but also that he is physically deficient: men who are *jundurak* are considered to be poor fighters. Such men are passed over as performers of *amulok kunik* and other rites. For example, although Mbabuarek was a second son, he used to perform *amulok kunik* and to organise the ceremonies for the *monggat* spirits of his agnates, as his elder brother was *jundurak*.

Cowards also are small men: during the ceremonies following battles and killings one reputedly gave pork to a coward with averted face, and only a small piece, while the big men received large pieces. The number of obtuse and cowardly men was relatively small. In the whole of Wanggulam there were about eight people who were generally included in these categories.

Another category of men with low status are the men whose manual skills and other physical qualities are below average: those who are not good in building fences and houses, and those who cannot trek fast. In this category are the confirmed bachelors, that is to say those

men who are well past the usual age of first marriage but whom no girl wants, or who have no valuables to form a bride price. In March 1961 there were ten bachelors among the Wanggulam, as against 99 married men. Five of the bachelors were feeble-minded and would probably never marry. Of the other five, two had married by the end of 1962. The other three were still young men. There were no middle-aged bachelors. I do not know whether this is accidental or whether formerly the chances of the young men were better, e.g. because a number of young men died on the field of battle. Bachelors are mildly ridiculed, but only in their absence. Supposing the father of a girl arranges a marriage with one of the bachelors, it is likely that she refuses or runs away a few days after the wedding.

A number of physical qualities make a man unattractive to a girl: a broad nose, a very heavy stature, or a very big penis. Lazy and cowardly men also are said to be handicapped. During 1960-62 there were no acknowledged lazy men among the Wanggulam. Another impediment for a man is to have sent away a girl soon after marrying her. Other girls fear that the same will happen to them and they become reluctant to accept such a man as a husband.

Lowest on the scale are the feeble-minded men. There are five of these men in Wanggulam. All were unmarried and four were *eiloman*. Each of the four was attached to an adult man, their 'false elder brother' (see p. 19). If he is not a member of the section of his false +B, the *eiloman* becomes one. Many Wanggulam appeared not to know the *anembeno* to which the *eiloman* originally belonged whereas they always knew in the case of other associates. The fifth of the feeble-minded men was at the beginning of the field work living with his classificatory B, who was also his MZS. Later he moved to his ZH. All five were obviously inferior to other men, not only to the man they were living with. The other Wanggulam required them to do all kinds of jobs they themselves disliked to do, for example to go and to draw water. Feeble-minded men are often openly ridiculed and teased. It is recognised that some of these men dispose of a great battle prowess. This is the case with two of the Wanggulam halfwits. They are the *eiloman* of Wandin and Mbabuarek. These attachments are not accidental: I was told that a warlike man was likely to have an *eiloman*, and then a warlike *eiloman*. Of the three other feeble-minded men only one was attached to a big man. The principle of autonomy leaves the members of society a wide range of private affairs and it supposes that people can manage these affairs: that they are able to perform

the tasks involved in agriculture and in running a household, that they are able to defend themselves and to protect their family and their properties, and that they are able to organise ceremonies and feasts and parties. Confirmed bachelors, feeble-minded men, and cowards are those who fail in these matters and who are no good at managing their affairs; big men and organisers of parties and feasts are those who are successful in this management. Common men look down upon and despise the former category, while they admire the latter.

## CHAPTER 7

### PARTNERSHIP

Mbogoga Dani say that the Wanggulam are *mun*, that they stick together, do not fight among themselves, and support each other in their fights with non-Wanggulam. They are *mun*, because they are grouped around a pair: two localised, adjacent groups, paired because they give each other their women.

Mbogoga parishes do not differ greatly in size; all are centered around a section pair and they are identified with these pairs as Penggu-Karoba is identified with Wanggulam. All parishes seem to include one or more smaller sections, as Wanggulam includes Mabu and Ngopare. These sections may have allies (just as Mabu and Ngopare are paired with Karoba and Penggu respectively), but such pairs do not form separate political units and they are very rarely referred to with the paired names of the constituent sections. Small sections may have no clear parish association.

Penggu and Karoba actually stick together: people remember few conflicts between these sections, either because they occurred rarely, or because recollection is suppressed. Either possibility is an indication of the strength of the principle of partnership. I heard about 131 bow and arrow fights in which one or more Wanggulam were parties. 26 of these resulted from conflicts between Wanggulam themselves; only six fights resulted from conflicts between Penggu and Karoba. In the 131 fights, 123 people were killed; in the 26 Wanggulam fights, 13 people were killed, in the six Penggu-Karoba fights only two. The fights between the Wanggulam and their neighbours led to a number of migrations either of the Wanggulam or of the neighbours. The fights between Penggu and Karoba did not lead to such moves. Conversely there is a great deal of friendly interaction between the two sections.

Comparing the number of recent intra- and inter-parish marriages, we find that there were 46 intra-parish marriages, whereas there were

98 marriages of Wanggulam men with foreign women, and 37 women married out. The intra-parish marriages form 25.4 % of the total number of recent marriages. With other exchanges the distinction between Wanggulam and non-Wanggulam is sharper. For instance, the great majority of known contributors to and recipients from wedding payments were Wanggulam (see tables 7, 8, 9 and 10).

Exchange of economic services takes place between parish members on a much larger scale than between members of different parishes. I witnessed only one work party organised by men from different parishes, and on all other parties and feasts the attendants were almost exclusively Wanggulam. When non-Wanggulam attended they were specially welcomed, in contrast to the other attendants.

With the expression 'partnership', a term I have chosen for want of a more appropriate, I refer not merely to a relationship of 'corporate affinity' (Salisbury; 1964b) between two groups. Instead I indicate with the term a complex of relationships uniting both the groups and their individual members. Whereas the groups are considered as united by corporate affinity and because of the proximity of their territories, their individual members are so united on the basis both of kin and affinal relationships and of co-residence.

The principle is another expression of the importance of reciprocity in framing Mbogoga relationships. That precisely this expression of reciprocity, the exchange of women, should be of fundamental importance in defining groups within Mbogoga may be explained by reference to Lévi-Strauss' theory on marriage:

Ainsi donc, l'exogamie doit être reconnue comme un élément important — sans doute comme, de très loin, l'élément le plus important — de cet ensemble solennel de manifestations qui, continuellement ou périodiquement, assurent l'intégration des unités partielles au sein du groupe total, et réclament la collaboration des groupes étrangers, (Lévi-Strauss; 1949, p. 595).

In this view marriage regulations, or in Lévi-Strauss' terminology: *la loi d'exogamie* — can be so important, because it est omniprésente, elle agit de façon permanente et continue, bien plus, elle porte sur des valeurs — les femmes — qui sont les valeurs par excellence, à la fois du point de vue biologique et du point de vue social, et sans lesquelles la vie n'est pas possible, ou tout au moins est réduite aux pires formes de l'abjection. (Lévi-Strauss; 1949, pp. 595-596).

Alliance as found among the Wanggulam implies marriage with MKBD, or MKZD, i.e. marriage with classificatory cross cousins. This system of marriage is, as Pouwer argues, 'probably' atypical for 'the whole mountainous area of Netherlands New Guinea' (1961, p. 17).

Pouwer expects to find systems with a great number of marriage units connected with other exchange units without marriage preferences. Compare also Barnes: 'In other words, matrimonial alliances are either concentrated or deliberately dispersed. The latter alternative is more common in the Highlands . . .' (1962, p. 8). Section pairs, however, are reported from a number of Western Dani societies; for the upper Swart Valley they are reported by O'Brien (1963), for the middle Swart by Wirz (1924, pp. 50 ff.). Bromley (1960, p. 241) and Larson (1962a, p. 32) mention the existence of 'linked patri-lineages' for respectively the Grand Baliem Valley and the Ilaga Valley. They do not mention specifically that the lineages are linked by marriage ties. Ellenberger reports units I call section pairs for a group of Uhunduni living north of the Carstensz Range (1962, p. 11). Peters states that among the Grand Baliem Valley Dani 'patri-lineages' may be linked by marriages between their members but that this is not necessarily so (Peters; 1965, p. 57).

The existence of groups united by preferential marriage does not invalidate Pouwer's argument because he hypothesises their absence as the result partly of an 'independent cultural choice', and partly of 'adaptation to an unfavourable environment and a poor technology' (1961, p. 9). The latter argument does not apply to the Western Dani nor to the Highlands societies in general with the same force as it does to other New Guinea societies.

The wide occurrence of section pairs in the Highlands of West New Guinea would seem to support Salisbury's hypothesis that 'African models are inadequate for the understanding of New Guinea society' (1964b, p. 169), also because 'the Siane and other Pacific and South-east Asian people conceptualise inter-group relations in terms of corporate affinity' (1964b, p. 170). Salisbury acknowledges Barnes' 1962 paper, but he does not mention to what extent he agrees with Barnes. It seems to me that emphasising the importance of corporate affinity in New Guinea society implies emphasising the importance of ties at the group level. Since Barnes argues that in the Highlands of New Guinea ties are prominent 'at the individual rather than at the group level' (1962, p. 7), it looks as if his and Salisbury's views differ sharply.

Dual relationships of the type of the Mbogoga section pair exist also in other parts of Melanesia outside the New Guinea highlands. Strathern reports that in Mbowamb social structure 'there is a pervasive and important principle of pairing' (Strathern; 1966, p.357). Held

notices dual relationships for the Bismarck archipelago, for Numfoor, and for the Sepik area (1951, pp. 30-31, p. 117, and pp. 128 ff.). He considers these groups as feasting groups, particularly in regard to religious ceremonies. This aspect is less prominent in the Mbogoga groups although it is not entirely absent. During the ceremonies following the killing of an enemy (see p. 49) paired sections, for example Penggu and Karoba, dance in two groups separately. The climax of the ceremonies is the transfer of an arrow representing the spirit of the dead man. The two sections dance, coming and going, alternately singing: 'Shall I give it to you?', 'Give it me', before the one group finally hands over the arrow to its ally. Supposing that Penggu has killed, then Karoba gives the arrow, whether the latter has joined the fight or not: the transfer is a ceremonial arrangement. In the present chapter I will concentrate upon the governmental aspects of the dual organisation.

The parishes are the largest functioning and enduring units in Mbogoga although the sections of one and the same parish may belong to different *anembeno* and the sections of one *anembeno* may be widely dispersed. Most Mbogoga *anembeno* have sections in more than one Mbogoga parish, while it may happen that still other sections live at the other side of the watershed in the catchment area of the Baliem, and in and beyond the Swart Valley (Wirz; 1924, pp. 49 and 52, and O'Brien; 1963). Several Wanggulam have visited other members of their *anembeno* living in the upper reaches of the Nogolo (see map II). Still farther west, in Ilaga *anembeno* are reported whose names show great resemblance to the *anembeno* names occurring in Mbogoga. The reporter, Larson, asserts that *anembeno* may be dispersed over the whole of the Dani area (Larson; 1962a, p. 33).

A number of *anembeno* are somehow thought to be identical. People express this by saying that they are 'one'. Sometimes 'oneness' is explained by referring to a common ancestor. Usually people say that members of identical *anembeno* are not allowed to marry each other. I came across a few cases of intermarriage which were justified by the fact that the *anembeno* 'had grown apart'. Next to exogamy, oneness of *anembeno* and ties between sections of an *anembeno* are expressed in:

a. relationships between individual *anembeno* members. Foreigners resident in a parish are often born either as members of the *anembeno* of which their host is also a member or as members of *anembeno* identical with the *anembeno* of their host. The majority of men main-

tain relationships with the members of other sections of their *anembeno* and go to visit them.

b. communal activities. These are very few. Wars between sections of one *anembeno* occur and are not condemned. Settlement of these wars follows the same lines as settlement of wars between unrelated groups such as sections of different *anembeno*, or unidentical *anembeno*. Mbogoga Dani tend to join fights fought anywhere in the valley. Alliances during the fights are often between sections of one *anembeno* and between identical *anembeno*. For the Mbogoga Dani, however, joining a fight is not necessarily an expression of solidarity with one of the fighting parties. During fights participants often pursue individual ends (see Case 22, p. 163) and moreover, people like fighting for its own sake.

Mbogoga Dani parishes do not combine into enduring units such as the confederacies reported for the Baliem Valley Dani by Bromley (1960, p. 242) and Peters (1965, p. 59) and for Ilaga Dani by Larson (1962a, p. 32). During the period from about 1935 until 1960 the Wanggulam fought all neighbouring parishes. Each of the neighbours had fights with its other neighbours. When joining a fight, a parish or part of a parish often divided into two, each half joining one of the fighting parties. It did occur that parishes joined each other in their entirety, but the people united on these occasions formed accidental groupings, which might not unite again. During such fights, men sometimes exerted power over people from more than one parish, mainly by means of proclamations to end or to adjourn battles.

Nowadays, the meetings organised by the missionaries and their Mbogoga pupils attract people from over the whole of the valley. The meetings lead sometimes to discussions, for example concerning thefts committed by members of one parish of the property of members of another parish. Here too, men from several parishes speak. However, in 1960-62 these discussions were regarded as accidental to these meetings.

Mbogoga *anembeno* are grouped into moieties called Weja and Wonda. Wanggulam say that the moieties are exogamous, but this is not in accordance with the facts; in some instances two *anembeno* who intermarry, and thus should belong to different moieties, both have marriage ties with a third *anembeno* which must belong to one or other of the moieties. Wanggulam do not realise this inconsistency. People know to which moiety their own *anembeno* belongs. Often they do not know to which moiety other *anembeno* belong. In practice,

marriage prohibitions between *anembeno* are not seen as the result of membership of the same moiety, but of identity of the *anembeno*. People planning a marriage often appear not to know the moiety to which their future spouse belongs. It happens that a woman marries consecutively a member of the one section of a section pair, and — after the death of this man — a member of the other section. In Wanggulam for example, a certain Ngopare woman first married a Penggu man, and later remarried a Karoba.

Near Karubaga, in the upper Swart Valley, there are no moieties, but section pairs do occur (O'Brien; 1963). Wirz mentions the existence of exogamous moieties in the Swart Valley (1924, pp. 47 ff.), but Le Roux mentions that the system as described by Wirz entails inter-marriage of clans belonging to the same moiety (1950, p. 674), which makes the actual exogamy of the moieties doubtful. Exogamous moieties are reported also for the Grand Baliem Valley (Bromley; 1960, p. 241 and Heider; 1962a) and for Ilaga (Larson; 1962a, p. 32).

The moiety organisation is another expression of reciprocity, using the same means, exchange of women, as in alliance, but operating in a much wider frame: moieties divide the whole of Mbogoga, and possibly a larger group of people, in two reciprocating halves, whereas alliance divides the political community. Supposed exogamy is the only explicit function of Mbogoga moieties. They do not act as units in any other sense.

Supposing the partnership principle were the only one moulding the Wanggulam parish, what would have been its form of government? There might have been a segmented parish consisting of two inter-marrying sections, each with its own territory, and each subdivided firstly into sub-sections on the basis of a division into '(descendants of the) first born son' and '(descendants of the) second born son', and, secondly, into sub-sub-sections on the basis of genealogical differentiations of more recent date. The segments would have consisted of the male members of the section or (sub-)sub-section, with their wives and children, and eventually their unmarried siblings and widowed mothers. The segments might have had contiguous territories, seeing that co-residence is relevant in the principle of partnership. Moreover, the kinship system adumbrates that rank is based upon seniority, and that the authority of father and elder brother enforces co-residence. Leadership of the segments would have rested with their eldest man. Leadership of each of the two main sections might have been decided upon by the genealogical charter underlying the segmentation of these groups. Possibly the existence of

the two main sections would have produced a dual system of leadership for the whole of the parish (cf. Bromley; 1962, p. 2). Leadership might have concerned the organisation of activities like harvest feasts, warfare, and agriculture, for example the allocation of garden land and the solution of quarrels.

Although features of the actual parish organisation give suggestions of it, this form of government does not exist. In order to discuss the actual role of partnership, I will describe the occasions on which the entire parish, one or more sections, or sub-divisions of sections act together.

First I discuss the affairs dealt with by parishes in their entirety. They are:

1. pigfeast;
2. warfare;
3. meetings and feasts organised by the missionaries.

The last category includes both Sunday meetings and feasts organised on the occasion of either Christian feast-days or important events in Mbogoga life. At these gatherings people from different parishes come together. It appears that during the initial dances the members of the different parishes merge completely (see p. 70). The only expressions of parish and section identity are first that when a newly arrived group prepares to join the dancers, a marked tension arises among its members. It seems to me that this expresses the awareness that one's own group is approaching a group of foreigners with whom one so often has been on bad terms. Secondly, during the subsequent parts of the gatherings, the speeches by the missionary or his pupils or the preparation of a meal following the speeches, the members of each of the different parishes sit down in one or more separate groups, often on section lines.

By warfare, the second of the occasions mentioned, I refer to the large scale fights following killings and other serious transgressions, like the theft of a woman. It was always said that retaliation of such transgressions was the affair of a whole parish. If a Karoba man is killed the whole of Wanggulam comes into action: Penggu, Mabu, and Ngopare help Karoba. Assembling of blood money is equally the affair of the whole parish. The last war the Mbogoga fought, in the beginning of 1960, started after the Wanggulam Penggu had killed a member of the southerly neighbours of Penggu. Due to the warlike situation Karoba retreated from the hamlets east of the Nganu (see map III). After government intervention, the Wanggulam paid compensation.

At least 14 pigs were transferred, of which the Karoba contributed four. Mabu and Ngopare contributed *jao* and shell bands. This incident shows also that the Karoba realised that their southerly neighbours held them also responsible for the killing committed by their ally, Penggu. Supposing that the Wanggulam join a battle between two other parishes, and that a Karoba kills one of the initial fighters, then the latter say: 'Penggu-Karoba is killing us'. The fight becomes more dangerous for the Wanggulam, as their opponents are likely to try to revenge themselves, not only on Karoba, but also on Mabu, Ngopare and Penggu.

Apart from the transfer of compensation warfare may result in other ceremonies, namely:

a. the ceremonies following killings held by the party responsible for the killing. Here the principle of partnership is expressed in the organisation of the dances (see p. 115).

b. reconciliation ceremonies, held after inter-parish killings. Their purpose is to end the situation of open hostility in which fights may start at any moment. Both parties bring pigs to the ceremony. These are exchanged and afterwards cooked and eaten so that the one party eats the pork provided by the other. The ceremony continues with dancing during which the parties form two separate groups. These formal reconciliations do not occur often. Most men I asked remembered only one or a few in which they had participated. In Chapter 8 a more extensive discussion of fights and the resulting settlements will be presented.

Pigfeasts, the first occasion mentioned, have been abandoned since the arrival of the missionaries, and — according to the Wanggulam — on the latter's instigation, because some of the ceremonies were consecrated to spirits, both *monggat* and *anggena*. Pigfeasts must be proclaimed and in Wanggulam there are only two men capable of doing so. According to the Wanggulam this is the usual situation; there are two proclaimers, and not more, one from each of the two main sections. Both Wanggulam proclaimers are big, according to the qualifications mentioned in Chapter 6. I included the capacity to proclaim the pigfeast among the special skills or knowledge promoting prestige mentioned in the last part of this Chapter. It seems that every parish holds a pigfeast about every four years. Each feast is proclaimed by one of the two men. Officially their feasts alternate, but in Wanggulam during the last decades the Karoba man proclaimed more feasts than the Penggu man. People say that they may try to influence these men

to postpone, or to advance the date of the proclamations, but I could not collect case material to this effect.

The first proclamation, accompanied by loud yells, concerns a prohibition on the killing or harvesting of a number of animals and crops, for a period of about three months. The feasts themselves extend over a number of days and consist of several distributions and dances. The main part of the feasts starts with a large scale killing and slaughtering of pigs. They are killed in the hamlet yards and steamed the same day in the hamlet garden. In a large hamlet there has to be more than one oven to accommodate all the pork. Most nuclear families shoot one or two, but rarely three, pigs for the main feasts. The participating units are the individual nuclear families, whether complete or incomplete. Other participants are confirmed bachelors (see p. 109). Erimawe for example, killed one adult pig for the last pigfeast. When men do not own adult pigs at the time of the feast, other people may give them parts of the pigs they killed, so that the former can join in the distribution. At the feast at which Erimawe killed one pig his mother's second husband, Ngabengga, did not have a pig and was presented with pork.

During the day the pigs are slaughtered and steamed, people are busy in all hamlets over the whole of Wanggulam; smoke rises from the fires heating the cooking stones. Wanggulam enjoy this time: they know that in the other parts of the valley people gather on lookouts to watch the spectacular view. On the evening of this day people go around through the whole of Wanggulam singing, joining each other, and handing out pork to everybody they meet. Non-Wanggulam are not present during this distribution, and the Wanggulam do not leave the parish. The pork consists of steaks. This part of the pig ranks second on the scale of appreciation. The sides with the fat are ranked first. This part is distributed on the next or one of the next days. The event is again announced by loud yells. This distribution takes place on a central feasting ground, on Wanggulam territory. As in the case of the pandanus feast, the distributions at the different feasts are held in the same area, although the exact location of the spot may differ. Husband and wife go together, although on other occasions men usually go together in one group and women in another group. The pork is laid down in large piles at the sides of the distribution ground. People deny that the segments of Wanggulam are recognisable as separate units. Many non-Wanggulam come surrounding the Wanggulam and the piles of pork. The distribution itself proceeds in much

the same way as the distribution of pandanus nuts during the feast in the Upper Swart area (see p. 86). The big men do not have a special function. In this case too the women have a say as to the distribution of the pork. Gifts are made to kinsmen, both cognates and affines, both Wanggulam and foreigners. They reciprocate former gifts, or are to be reciprocated by future gifts at the same or one of the following feasts. Although people are busy themselves getting and distributing the pork, they keep an eye on how much others receive and from whom, and they query each other afterwards for the reason of the gifts. After the distribution the men dance on the feasting ground. The next day the ceremonies are continued but non-Wanggulam do not take any further part.

The Wanggulam say that a pig feast is a counter-prestation for previous feasts organised by other parishes. Nevertheless, the gifts of pork made at the distributions are links in chains of prestations between individuals. This indicates that in Mbogoga the transactions made during the pig feasts are simultaneously transactions between individuals and between parishes. This feature seems to be a characteristic of a great many of New Guinea Highlands exchange transactions:

Although exchanges and prestations may be spoken of as arranged by the clan or sub-clan and may even be timed on a regional basis, the great majority of these ceremonial transactions are undisguisedly transactions between individuals (Barnes; 1962, p. 7).

The organisation of the pigfeast on the one hand shows the autonomy of the adults; there is no central organisation and people pursue their own interests by presenting pork to their own relatives only. During the distribution sections or vicinages or their constituent parts do not act as units. As is the case with the pandanus feasts, people join on their own accord and would dislike not to join. A man's prestige suffers when he does not take part. The more pigs he kills for a feast, the more prestige he earns. The text of one of the songs sung during the feasts consists primarily of enumerations of the individual men who had shot pigs for the feast. However, since pigs are owned by husband and wife jointly and since wives reputedly have a say in the disposal of pork, the men's autonomy is clearly not absolute.

Having mentioned the affairs concerning the parish as a whole, I turn now to describe the affairs dealt with by the constituent parts of a parish. The main sections deal with:

1. harvest feasts, like the pandanus feast organised by Penggu already described;
2. solution of serious quarrels.

Smaller subdivisions, or sub-subdivisions of the parish, deal with affairs like minor quarrels or working parties. I discuss these affairs in the order mentioned.

*Harvest feasts.*

When describing the Penggu pandanus feast I did not mention the role of section and sub-section membership in determining ownership of the eleven earth ovens. This is the subject of the next case.

CASE 10, OWNERSHIP OF EARTH OVENS DURING THE PENGGU  
PANDANUS FEAST

In the days preceding the feast I tried to find out how many ovens would be used during the feast and who would own them. This was a matter of great interest to the Wanggulam and several men told me about it. Their accounts however were contradictory and did not accord with the arrangements actually made. For example, on the morning of the feast Ngwigak, a young man who had visited the feasting ground and who lived in the same hamlet as Wandin, the director of the feast, told me that there would be ten earth ovens and that they would be owned in the following way:

1. owned by Wandin;
2. Jaipuk and Manggumbini;
3. Kondaga and Noge;
4. Ngwembanik and Autlen;
5. Lenit;
6. Ngwabem and Ngwembuk;
7. Karoba, without further specification of ownership;
8. Karoba;
9. to be used for *kuma* beans; no further specification of ownership;
10. to be used for *kuma* beans.

Later in the day it appeared that the actual ownership was as follows:

1. owned by Ngwembanik (see also the Appendix);
2. Jaipuk, Manggumbini and Arigunik;
3. Mbobigi, Tanarak, Tikit, Mbabuarek, Ponarit, Lenggaroba, and Wuran;
4. Komak and Nginarek;
5. Ngwabem, Ngwembuk, Mbumak, Itatmolok, and Arinogarak;
6. Kondaga, Noge, Jilimanggen and Ngubunarit;
7. Ngombo, Porononggen, and Langgu-Langgu;
8. Wandin, Panimarek and Ngwigak;
9. Lenit and Enorit;
10. Autlen and Pularit.

Still later a number of Ngopare men added the eleventh oven. The men mentioned in the second list are all the owners of the first ten ovens. As 'owners' I take only men taking part in the exchange of valuables: married men and bachelors over about the age of 20 (see p. 37). All owners were members of Penggu except for:

1. Nginarek (oven 4) who was living with Komak, his MZS;
2. Manggumbini, and his son Arigunik (oven 2). Manggumbini was living together with Jaipuk, his MKBS. Arigunik was living together with his WF, who himself did not participate.

All owners were living on Penggu territory except for:

1. Ngombo (oven 7) who was one of the mission pupils. Before he left for Mbogondini, he lived in a hamlet together with Langgu-Langu;
2. Lenggaroba and Wuran who lived on Mabu, or former Mabu territory.

Almost all people living on Penggu territory took part in the feast. One sub-section did not participate, except for Mbumak (oven 5), allegedly because its members did not have any pandanus. Jiwaru, Komak's —B, did not participate because he did not have enough pandanus and Wandin did not assent to his request for a number of fruits. The only Karoba living on Penggu territory, Ngabengga, did not take part. People said that he would take part in the forthcoming feast to be organised by Karoba. My data do not show whether Ngomengga participated and, if so, with whom; Ngomengga is a FBS of Autlen (oven 10). He, his only son, and an *eiloman* are living on their own in one hamlet. Ngomengga is a small man and he does not own many pandanus trees.

The data necessary to analyse the part which three principles: (I) kinship, (II) residence, and (III) the relative prestige position of the owners, have in the composition of the groups owning the ovens are presented in the Appendix.

The initial column shows:

- a. the number of the row;
- b. the number of the oven.

In order to arrange the genealogies according to sub-sections the sequence of the ovens had to be rearranged and they could not be dealt with in numerical order. As the numbers reflect the location of the ovens, this implies that location of the ovens and the genealogical differentiation of the owners do not go hand in hand. The genealogy represents all Penggu men of about 20 years and older. The names of Penggu men who did not take part in the feast are either omitted or put within brackets.

The other columns of the Appendix indicate:

- Ia whether the group of owners contains agnates only, and — if not — what are the relationships with the Penggu owner;

- Ib whether the agnatic members of the group belong to one sub-section;
- Ic whether the agnatic members include all the men of one sub-section who are 20 years and older, or — if they are drawn from more than one sub-section — how many sub-sections are represented and whether the agnatic members include all men of these sub-sections who are twenty years and older.
- IIa whether the group of owners contains two or more men residing in one hamlet;
- IIb whether the group co-resides in one hamlet;
- IIc whether it includes all men of one hamlet who are 20 years and older, or — if it contains people from more than one hamlets — how many hamlets are represented, and whether it includes all men from these hamlets who are 20 years and older.
- III the genealogical connections between the joint owners. A double triangle indicates a big man. The sub-sections are indicated by P a, P b, and so on.

In columns I and IIa '+' indicates a positive instance, a '—' a negative instance. If there is only one owner, the case does not provide information concerning the relationship between joint owners. If the owner is the only man living in a hamlet who could qualify as such, or if the group of owners contains only one member of Penggu, joint ownership does not provide information on whether there is co-operation between co-residents and members of different sub-sections. These cases are indicated with the symbol '/'.

As an example: row 8 indicates that the group of joint owners of oven 6:

- (Ia) contains only agnatically related men
- (Ib) is drawn from one sub-section.
- (IIa) the group contains men co-residing in one hamlet.
- (IIb) the group contains men from more than one hamlet
- (IIc) namely from two hamlets. The group does not include all men of one of the hamlets who are 20 years and older, while only one such man lives in the other hamlet.
- (III) The group contains two big men.

In two cases only (numbers 6 and 7) are joint owners drawn from more than one sub-section. In both cases the men are united by co-residence. In only one case (number 3) the group contains the whole of one sub-section. The other sub-sections did not act as units during the feast. The location of the ovens did not bear upon the subdivision into sub-sections. All groups of joint owners contain one or more men residing in the same hamlet, except in one case (number 9), where Ngombo had left for Mbogondini. Of the other nine groups four are drawn from one hamlet (numbers 2, 4, 5 and 6).

The members of Penggu lived in 15 hamlets. The owners of the ovens were drawn from 11 hamlets. In one of these hamlets a man lived on his own, with his wife and children. With seven of the other

ten hamlets the male inhabitants of 20 years and older formed the whole or a part of a group of joint owners. In only two cases (numbers 4 and 6) the male inhabitants of one hamlet who are 20 years and older form the whole of a group of joint owners.

Seven out of the ten groups of joint owners contain one big man, one contains two big men (number 8), and two do not contain a big man (numbers 3 and 5).

I would argue that in the organisation of the feast, and in the co-operation expressed in joint ownership autonomy, partnership and leadership are operative. Because all these principles are operative they impede each other. This fits in with the contradictions in the information provided during the days preceding the feast: the autonomy principle precludes people from having clearcut criteria to classify the Penggu into groups. It also prevents the groups of joint owners being strictly and solely based upon the subdivision into sub-sections, or on co-residence, or on the relative prestige position of the men.

The next case, a fight between two sub-sections, shows that in these circumstances also, the kinship and residential groups do not act in their entirety.

#### CASE 11, LUKI VERSUS AMBENGGONOK

Luki, a Karoba II (see Figure 8) got angry with Ambenggonok, a Karoba I, after the latter had tried to help Luki's own and elder brother's sons to cross the Mbogo. Ambenggonok had failed and the two boys had drowned. Luki presumed foul play by Ambenggonok, and asked for compensation (he would have asked for compensation also if, in his view, the deaths had been natural). When Ambenggonok did not show any intention of paying, Luki decided that he would have another son by Ambenggonok's wife. He managed to abduct the woman, and took her to his hamlet. She stayed with him. Ambenggonok organised a raid to get her back. Together with a number of Karoba I men he went to Luki's hamlet where a bow and arrow fight developed. When Ambenggonok tried to approach the hamlet from another side he was noticed, put to flight, and killed not far from the hamlet. This killing caused a great fight lasting for several days in which men from over the whole of Mbogoga participated. After a few days of fighting there were no casualties, so that the big men urged the combatants to stop lest other quarrels should start from other killings. Luki agreed to pay compensation.

The fight in which Ambenggonok was killed was described as a fight between Karoba I and Karoba II. Actually not all members of Karoba I participated. I could not find out why they did not participate. On the side of Luki two Karoba II did not participate. Katlengga, a big man, fought on the side of Karoba I, 'because he pitied his peer'



of Karoba I did not receive. A further discussion of this compensation payment will be given in the next Chapter.

Although these data are incomplete they show that the sub-sections, as in the case of the pandanus feast, did not act as units. Although people used the names of the sub-sections to identify the groups, it appears that other factors — Katlengga's bigness and daring, and Kelele's anger — influenced the situation.

With the organisation of smaller gatherings, the same phenomenon can be noticed; the group working or celebrating together contains many co-residents and many people from one patrilineal group, but usually not all the people from one hamlet or one kinship group, and usually contains some people from other hamlets and other kin groups. Participation is mostly explained in terms of kinship or of residence, not only by reference to close relationships as between mother's brother and sister's son, or between residents of the same hamlet, but also by reference to a broad relationship such as 'He belongs to our ally', or merely: 'He is also a Wanggulam'. Sometimes people say they have no particular reason but just go to assist.

These gatherings are named after the man or men who organise them, or by the name of the hamlet the organisers inhabit. In the latter case also the name refers to the men who derive prestige from the occasion, and not to the group which actually gets together. The fights and the large scale feasts are referred to by the names of the units which are concerned: Karoba I and Karoba II, in the case of Ambenggonok's killing: Penggu, in the case of the pandanus feast. The former category, events of less importance than fights and large scale feasts, are the affairs of an accidental group of people. They are not parish affairs and consequently the role of the groups defined by the principle of partnership is even more restricted.

Apart from the small working parties and harvest feasts, the occasions mentioned do not belong to the daily affairs of the Wanggulam. They occurred once every four or five years, as in the case of the pigfeasts, or a few times every year as in the case of the fights, the harvest feasts, and the dances. Qualitatively these events stand out. There is much talking about them and people enjoy taking part in them. In the case of the fights they might have been scared at the time, but afterwards they enjoyed being able to say they had taken part.

On several of these occasions big men act as leaders, but kin ties also may be of importance in deciding who is to be the leader. This

appears most clearly during wedding and cremation ceremonies and after killings on the field of battle.

The date for a girl's wedding is set by the man who reared her, therefore usually by her father, or — if this man had died — by her closest male adult agnatic relative or her mother's second husband. The man properly responsible was never passed over in the organisation of a wedding ceremony. Close kinsmen or co-residents, however, may try to influence him and to have the date altered. The actual authority of the father during the ceremonies is small (as is the authority of the organiser of a working party). The actual dressing of the girl is not his concern; it is done by women. The men are concerned with welcoming the guests, collecting the *uak* and arranging the *jao* and the shell bands which are laid down on the hamlet yard. The culmination of the ceremony is the distribution of pork to the contributors to the *uak*. This takes place at the beginning of the afternoon, after the dressing of the girl has been completed. It is a hectic affair and most adult men present give their unasked-for advice and comment. The father himself may cut the pork and hand out the pieces, but usually during the distribution he forgets which of the contributors he has already remunerated and which he has not, so that he has to rely upon the advice of other men squatting down round the pork. The father may also sit at a distance, while other men cut the pork, and shout his advice to the cutters, who often cannot understand him because of the noise of the other attendants, but who continue handing out pork. But when the girl's father at the conclusion of the distribution is about to announce the identity of his daughter's future husband, a sudden silence reigns and everybody is intent upon hearing this man's identity. The silence is broken immediately when young men rush off to inform the prospective groom.

When the bride is brought over to the hamlet of the groom, the father of the bride does not have an important role until the distribution of the bride price. During the morning his daughter is again dressed in her marriage skirt. At the beginning of the afternoon she is brought to the hamlet of the groom by her father and his relatives on either side. In the meantime the father of the groom and his relatives are preparing a meal, which is nearly cooked when the bride and her party arrive. The father of the groom goes on assembling the contributions to the bride price. After the meal the fathers of bride and groom, each usually advised by one or two other men, hold a whispered conversation concerning the size of the bride price and whether it

covers the *uak* or not. When the father of the bride accepts the payment, he immediately starts the distribution. On a number of occasions I witnessed he was confused by the again unasked-for advice of other people around him, but on others he managed to decide for himself, sometimes helped by his wife.

Just as wedding ceremonies are organised by the closest relative of the bride, so a cremation is organised by the closest relative of the deceased and as with the other ceremonies his leading position appears most clearly in the assembling and distribution of the payment, viz. the cremation payment. The course of this part of the ceremony is similar to that of the assembling and distribution of the wedding payments. The payment itself is much smaller and the atmosphere is more subdued, either because smaller interests are at stake, or because of the nature of the ceremony. Bystanders are less inclined to give advice during the distribution.

When discussing the role of big men I mentioned that on the field of battle they have to defer to the closest relative of a killed man. This relative can decide whether to end the battle or not. This is a qualification of autonomy in so far as other fighters, who may have joined the battle with a particular revenge in mind (see discussion in Chapter 8), are commanded to stop fighting although they may not yet have attained their goal.

Here too leadership is open: people derive their authority from the fact that — because their relative has been killed — they have a far greater interest at stake than the other fighters. By becoming the closest relative of a killed man, every man can act as an instrument of government. Furthermore, the payment compensating the killing is distributed by the closest relative of the man killed. This will be further discussed in Chapter 8.

This role and those of the organisers of wedding ceremonies and cremations is open to all male members of society; it depends on the course of events who will fill them.

There are a number of men whose position is enhanced because they possess a special skill or knowledge. In many of these cases the positions are obtained through kin relationships; personal qualities are less important. For example the specialists who know how to control a particular spirit (see p. 50) learn the treatment from their father or the man who reared them. The number of these specialists is rather large in Wanggulam. Moreover there are men with other skills: a few

men are reputed to be able interpreters of dreams, a few others are able to chase spirits supposed to have entered one's body.<sup>1</sup>

Further, in most parishes there are a couple of men who proclaim the pigfeasts. Lastly, not all men know how to carve the heads of the arrows used for shooting human beings. They have to ask others to make a few for them.

I heard about in total 23 men, apart from the arrow carvers, who had a special skill or knowledge. With this category of leaders openness is expressed in the large number of these specialists and the possibility that other rites and ceremonies were introduced from other parts of Mbogoga or other areas (see p. 51). As most specialists had discontinued their practices, it was not easy to discover whether these men became influential on account of their skill or knowledge, and whether people tried to keep friends with them to be more sure of their services. By 1960 nothing indicated that this had been the case. From the way people told about the 'doings', it seemed as if they merely admired the skills and knowledge the specialists had and they themselves lacked. Rewards to the specialists are mostly made in pork. Arrows are paid for with shells. The interpreters of dreams are rewarded with *kanembuk*, small sized shells, which people, mostly men, used to wear in short straight strings on the chest. I was told that men, reputed to be good interpreters of dreams, wore a number of these strings for which they were greatly admired.

In Chapter 3 I mentioned that the basic unit in Wanggulam economy is the nuclear family and that larger groups like hamlet groups and sub-sections do not have an essential role; there is not much co-operation and co-ordination in everyday life between the individual households. This becomes more marked when one considers the changes taking place over time. The residential mobility is high and people are apt to change their allegiance from one kinsman to the other.

The residence pattern is not a simple reflection of agnatic kin relationships and the sections are not clearly demarcated groups either in regard to their territories or in regard to membership. Sometimes Wanggulam seem to think that their sections are groups with membership closed on the basis of patrilineal descent, sometimes they seem to think that people can acquire membership through co-residence.

---

<sup>1</sup> One of the Wanggulam theories to explain diseases assumes that a spirit has entered the body of a sick person. Sometimes people say they know which spirit has entered the body; sometimes they profess ignorance about the type of the spirit and its name.

On yet other occasions people say that they establish relationships by continuing exchanges, not mentioning kin or residential ties.

The main sections do not have a uniform pattern of segmentation. Karoba is divided into three sub-sections, Penggu into five much smaller groups (see Table 2, p. 15). The smallest of the Karoba sub-sections is sub-divided, while the larger are not.

In Chapter 6 I mentioned that it is the most successful fighters who are powerful, rather than the senior men of the (sub-)sections.

Nevertheless, alliance, kinship and co-residence have great significance for the Mbogoga Dani. The Wanggulam say that Penggu-Karoba has existed for a long time, though they profess ignorance about how long it has existed and how it came into being. They say also that it will continue to exist during the lifetime of their children and their further descendants. On account of partnership the Wanggulam identify themselves as a group distinct from others; they are *mun*; they stick together; they have pigfeasts together. They have outside responsibility for acts committed by their co-parishioners. Agnatic kinship has an important role in influencing residence, albeit not the only one; it has an important role in the formation of groups who have their harvest feast together or who form a fighting party. Not only 'Penggu-Karoba', but also 'Penggu' and 'Karoba' are significant concepts for the Wanggulam. The pandanus feast was 'steamed by Penggu'. When sections quarrel, people often use the name of the sections to refer to the parties next to the names of the principal quarrellers. This applies also to sub-sections; the fight in which Ambenggonok was killed was often referred to as a fight between *manggu* (i.e. 'the first son', Karoba I) and *opatengga* (i.e. 'the second born son', Karoba II). Moreover, most of the fighters aligned themselves in accordance with their sub-section membership.

Furthermore, kinship groups do segment; it is said that Karoba I and Karoba III separated only 'recently', because the group became 'too large'. The main sections have contiguous territories.

Finally, people who change parish membership can usually appeal to one of the three relationships incorporated in partnership: either to an affinal or cognatic relationship based upon a marriage of one of the relatives of the newcomer with one of the members of the host parish, or to agnatic kinship, namely in those cases in which the newcomer is a member of a clan identical with a clan one of the sections of which is part of the host parish. The longer the newcomer is a co-resident (the third relationship), the more his hosts become convinced that he will remain permanently.

To explain these phenomena I argue that partnership is not the only principle prevailing. It is curtailed by the other principles. In several situations they impinge upon each other, so that one or more have to give way. For example, the contradictions in the statements of the Wanggulam about membership and association arise from the fact that there are several principles at work. According to the principle of partnership a newcomer is not a member of the parish, while according to the principle of autonomy he can become a member if the other members of the group agree.

Before discussing this interplay further, I first examine the several types of conflicts occurring among the Wanggulam and the methods used to settle conflicts.

## CHAPTER 8

### CONFLICTS AND SETTLEMENTS

Wanggulam adults put a high value on being good fighters, and as they have the ultimate means of force at their disposal, it seems likely that they are inclined to use and over-use these means. In fact, people remember the time before the arrival of Europeans as one of continual fighting. They know the facts of a large number of brawls and fights. During my stay in Wanggulam I collected fairly extensive data concerning 131 cases of trouble, including a number of retaliations ranging over a number of years. The cases contain in total 393 disturbances, though the records of a number of them are incomplete. The Wanggulam were directly involved in all the cases. Almost all took place during the last 25 years. They include all the major battles the Wanggulam had to fight, except for those which occurred during the time they spent in refuge outside Mbogoga, but they do not include all the minor fights and disturbances.

Although hostile relationships are based upon reciprocity, serious conflicts are often the outcome of less important transgressions: an initial breach, or presumed breach of certain norms is followed by a counter-action. The party against which the counter-action is directed considers it unwarranted or exceeding the initial offence, and proceeds to another counter-action. In this stage a fight with bow and arrows is likely. Undue retaliation may be caused by tension or hostile feelings, as exists between the parishes, but it is also often caused by *mum*. Its believed outcome is always death, which is often more serious than the initial breach of norm. The fights between the Wanggulam and the Tukobak, their southerly neighbours, in which the Wanggulam suffered heavy losses and fled from Mbogoga, had been preceded by a long series of retaliations. These are recorded in the next case.

#### CASE 12, PRELIMINARIES TO FIGHTS BETWEEN WANGGULAM AND TUKOBAK

Whenever I asked people why the Tukobak, led by their biggest big man, Jikwanak, had attacked the Wanggulam, I was always told

that this had happened in retaliation for former killings. A number of Wanggulam led by Kondaga, a Penggu, had killed two members of a foreign Penggu section which had supported Jikwanak and the Tukobak. The Wanggulam had killed the two, a father and his small son, in his swidden on the other bank of the Luaga.

This had happened in retaliation for a former killing: Jikwanak had killed Kondaga's elder brother. Afterwards Jikwanak had fled so that the Wanggulam retaliated by killing one of his supporters and his son. Jiwanak in his turn had killed Kondaga's elder brother in retaliation, since the Wanggulam Karoba had killed Mogu, Jikwanak's classificatory younger brother. Mogu's killing had also been a retaliation since Mogu and Jikwanak had killed the father of Wandamendek, a Wanggulam Karoba.

This sequence of events was told me independently by three men. When I asked one of them, Wogogi, why Wandamendek's father had been killed, he smiled, waited a moment and said: '*Ap warak*', 'Because of another killing'. This answer was given me on a number of occasions during inquiries about the motive for killings, and was reiterated even when it appeared that people did not know the precise motive.

Of those Wanggulam I questioned, Wandamendek was the only one who could provide further information. He said that his father had been killed by Jikwanak after a classificatory elder brother of Jikwanak had died. Jikwanak thought that his classificatory brother's death was due to sorcery, worked by a father's sister of Wandamendek's classificatory elder brother. Her motive for working sorcery had been that she had not received compensation for her own father's death. This man had gone together with a Tukobak on a long trek through the jungle to Panaga, in the Swart Valley. During this journey a spirit had reputedly killed him. On such occasions a companion of the dead man is likely to be held responsible and he should pay compensation. In this case compensation was demanded and when it was not offered, the dead man's daughter had resorted to *mum*.

I could not ascertain how much time went by in the course of these retaliations. I estimate Jikwanak was in his late fifties during my field work, so that he can have started his career as a fighter around 1925. Wandamendek was about 40 during my field work and he was two generations younger than the man who died during his trek in the jungle. Supposing this man was 40 years older than Wandamendek and that he was 50 when he died, then his death occurred around 1930. Since he was two generations older than Wandamendek, he may have been more than 40 years his senior. Furthermore, he may have been much younger when he died. If so, his death has occurred much earlier. The big fights between the Tukobak and the Wanggulam probably took place about 1942 so that it is at least possible that the preliminary fights were spread over several years.

The above mentioned series of retaliations was not the only preliminary to the fighting which made the Wanggulam leave Mbogoga. The fighting concerned at least three parishes: Tukobak, Mbilu,

Wanggulam's easterly neighbour, and Wanggulam. The Tukobak and the Mbilu were on bad terms after a Mbilu woman had reputedly killed a Tukobak by sorcery. The Mbilu were defeated by the Tukobak and also left Mbogoga. Moreover the fights were also a retaliation for the killing of the Ngigamuli mentioned in Case 8. One of the big men of the Tukobak, Ndanguarek, was the son of a female Ngigamuli and he had urged fighting the Wanggulam so that the death of the three Ngigamuli might be avenged. I did not manage to find out all the details of this aspect of the fights. I do not know for example how much support Ndanguarek got. It seems likely that the people most inclined to support him were those Tukobak who also had close kin relationships with the Ngigamuli and I do not know how many Tukobak were in this position. Moreover, the situation was the more complex since the Ngigamuli formed part of the Mbilu, and hence were at that time enemies of the Tukobak.

Fights occur between very close relatives. The trouble cases include 75 bow and arrow fights which took the lives of more than 142 people, among whom 50 were Wanggulam. Wanggulam conflicts are often concerned with:

1. Neglect of domestic duties, for example the collection of firewood or the preparation of tasty and sufficient food, occurs 14 times in the cases. These quarrels rarely lead to further disturbances, so that people soon forget about them. The outcome often is that one of the quarrellers moves away, either temporarily or indefinitely.

2. Wanggulam steal a great deal, and 63 thefts occur in the cases. Thefts of minor properties normally do not lead to serious hostilities, but those of the highly valued belongings like pigs and *jao* may lead to bow and arrow fights. The number of thefts, the Wanggulam claim, has decreased a great deal since the missionaries began to exert an influence. Reactions to thefts are said to be less violent nowadays than formerly.

3. The number of conflicts concerning women is 39. Sexual intercourse between married or unmarried men and unmarried girls occurs quite often and people do not have strong feelings about it. It rarely leads to quarrelling. Conflicts arise only when a married woman is involved; adultery of this kind tends to have a serious aftermath. Wanggulam told me that the causes for the fights they had formerly were 'always' either previous killings or thefts of women.

4. Conflicts over compensation payments occur 22 times. In the same way as the wedding payments, payments are assembled by and distributed to a large number of people. It often takes a long time before

a payment is assembled, even when there is no attempt to postpone the transfer indefinitely. At the actual transfer it may seem that not enough has been assembled, and this may lead to further quarrelling.

Unlike a theft or a quarrel concerning a woman, any form of physical violence is regarded as the result of former quarrels. The same holds for *mum*: people think that men do not start fights for nothing and that women do not work *mum* for nothing. The case histories confirm these notions: for almost all instances of violence and *mum* people could tell me a preceding breach of norm. When they could not, they said they had forgotten or had not heard about all the facts of the case.

Thefts of property and of women are often committed by small groups of men. Because many men are willing to stage a raid, and there are no men wielding the power and authority to check them, the raids are a serious threat to peaceful conditions. A group of men like the group operating in the next case is only one of many, which — on the spur of the moment — Wanggulam can form. (compare also Case 5, Wandin versus Mbabuarek, p. 91, and Case 6, Wogogi's dog, p. 92). The case shows also how Wanggulam quarrels sometimes include several retaliations.

#### CASE 13, LIOKWE RECOVERS HIS PIG

When Kuranggen, a Karoba I, fled to Abena after the Wanggulam lost the fight with the Tukobak (see p. 2), he had to carry his younger sister, who could not walk the whole of the way. She was heavy, and he gave her to carry to a number of men from the easterly neighbouring parish, the Mbilu, who also had to flee. He promised the men that he would marry the girl to one of them.

When she had come of age, it appeared that she did not want to marry any of the men, but wanted a Penggu, Ngomengga. She actually married him, whereupon the neighbours asked Kuranggen for compensation. When Kuranggen seemed unwilling to pay, they came to Wanggulam and stole a pig they thought to be one of Kuranggen's. In fact it was a pig belonging to Liokwe, also a Karoba. Liokwe in his turn got angry and planned a raid. He is not a big man, and was at that time still rather young, aged about 30. He arranged with three other men, his brothers Wogogi and Ngunduarek, and a Mabu, the son of a female member of his sub-section, to steal a pig from the Mbilu. The Mabu man lived with Liokwe and a number of other men in one hamlet. Wogogi and Ngunduarek lived elsewhere. The four men did not tell anybody what they were going to do for fear people would advise them against going and later on would refuse to support the raiders. The raid was a success. The men captured a large pig which they took away with them. It was steamed in

Nogombumbu, the most easterly hamlet of Wanggulam, and pork was distributed freely. This too was a precaution. If raiders do not distribute the spoils of a raid, people are not prepared to support them if the enemy should try to retaliate. I was also told that people are more readily prepared to approve of a raid when they are offered pork. If they still disapprove they refuse the pork, but this is done 'only by cowards'.

The theft and the meal took place during the night; the Karoba expected an attack and kept watch. They were joined by Penggu and Mabu. A few men were already performing *amulok kunik*. The next morning the Mbilu did attack, but they were halted. The fight went on and one of the attackers was killed. His elder brother called for peace, asking for *jowam*. The Wanggulam agreed and actually transferred the payment a few days later. Ngomengga was the only Penggu who contributed a pig, whereas the Karoba contributed six pigs. Other Mabu and Penggu gave *jao* and shell bands.

The information I have about the willingness of Wanggulam co-parishioners to support raiders is not entirely consistent. There seems to be little reason why people should accept the *fait accompli*. Perhaps the Wanggulam implied that after being advised not to proceed, the raiders had less chance of support in the case of failure, whereas their co-parishioners, if ignorant of all the facts of the case, might notice the difficult position of the raiders and more readily come to help them. Another reason for secrecy might be that someone told about the plan might reveal it to the enemy.

The Wanggulam have the following procedures at their disposal to redress an imbalance in their relationships, or simply to avoid further hostilities:

1. moves and avoidances;
2. compensation payments;
3. a number of supernatural practices, of which *mum* is the most important;
4. fights.

The threat of force is always present in these procedures, and although individuals themselves have to take the initiative in order to redress the imbalance resulting from the initial breach of norm, the community approves of their action. The Wanggulam think it is correct that a killing should be balanced by another killing, and that a theft is answered by another theft of an object of the same value. To decide whether retaliation is correct or not, they apply the principle

of reciprocity. Such retaliations form part of, in Hoebel's sense, a legal system.<sup>1</sup>

I did not come across a single case in which a group took action against one of its members. There was no case known of the 'not-to-be-borne-any-longer-recalcitrant', mentioned by Hoebel as the only type of criminal found among the Barama River Caribs and the Eskimos (1954, p. 300). This is in accord with the strong feelings of autonomy the Wanggulam have; accordingly there are few public affairs. The Wanggulam say that they know about excessively warlike and combative men. The reputation of these men is that they die early; people cannot give a specific reason why this happens. A reason may be that such men make too many enemies and are unable to remain ever prepared for the many attacks upon their lives made by their enemies. As a result of the principle of autonomy, people do not take parish action against one of their co-parishioners, and hence crimes do not exist in Wanggulam society. Breaches of norms constitute torts.

When Wanggulam tell about cases of retaliation, they are more interested in the quarrel itself than in the correctness of the behaviour of the litigants. Many people know how to narrate cases of trouble quite dramatically, invoking the laughter of the listeners. Mostly people are unwilling to judge the behaviour of the litigants, saying it is not their affair. It seems they consider it to be the affair of the parties concerned whether they will continue their quarrel or not, and whatever actions they may take, and this tendency seems to be in accordance with the Wanggulam feelings of autonomy.<sup>2</sup>

When specifically asked whether they approve or disapprove, Wanggulam do express an opinion, but without strong feelings; when they condemn behaviour as *maluk*, as 'bad', this concept has often the connotation of 'technically incorrect' more than of 'wicked'. Legal

---

<sup>1</sup> A social norm is legal if its neglect or infraction is regularly met, in threat or in fact, by the application of physical force, by an individual or group possessing the socially recognized privilege of so acting. (Hoebel; 1954, p. 28).

<sup>2</sup> Read notices the same unwillingness among the Gahuku-Gama and other New Guinea peoples and relates this to the fact that 'their moral rules are, for the most part, unsystematised — judgements which refer to specific situations rather than to any explicit ideology of right and wrong as such.' (1955, p. 282). This may be the case, but it does not seem to offer an explanation, because among both the Gahuku-Gama and the Wanggulam people are also unwilling to judge actual behaviour as it occurs in specific social situations, for example, when discussing a case of trouble (see Read; 1955, p. 281).

judgments do not have strong moral support. Stronger disapproval is shown more by men than by women, when they speak in general terms about *mum*; although people then use the same term *maluk*, they use it with more conviction and emphasis. When a woman expresses her disapproval of *mum*, she quickly adds that she herself does not know how to work it. I seldom met with indignation, except in the quarrellers themselves, but it was apparent in a number of people on the day Arigunik tried to capture Jiwaru's wives: 'A bad man, Jiwaru, he told his wives to work *mum* against Arigunik's younger sister'.

Wanggulam do not take great interest in whether people retaliate or not and in only a few cases — such as the one just mentioned — do people proceed backed by the active sentiments of a considerable part of the community. Since even these reactions are not organised by the parish or by parish-functionaries, the absence of crimes in Wanggulam society is confirmed.

I will discuss the four procedures to redress an imbalance or to avoid further hostilities in the order mentioned.

#### 1. *Moves and avoidances*

In a number of quarrels parties do not bring their dispute to a close. They avoid each other and overt expressions of hostility do not occur. This happened for instance in the following case.

#### CASE 14, OPENING OF AGAWAK

During the season of 1961, a number of men, almost all adults of Karoba II together with one man from Karoba III, made a swidden in Agawak, a tract of land on the ridge between Mbogo and Kurip. Members of Karoba I told me that they had opened Agawak before, and that Karoba II was not allowed to do so. The latter told me that the former had not opened this particular part of Agawak, but the tract adjoining it to the east. There were no clear landmarks in the area.

One of the Karoba I men got angry with the Karoba III who was among the openers. The latter lived with him in one hamlet and was his MKZDS. The Karoba I asked his relative for the shell band he had given him: 'Why should I give you a shell band when you have joined Karoba II who have infringed on my rights'. The Karoba I did not prevent the Karoba II from using the garden, but during the next season, cancelling former plans, they opened the easterly tract of Agawak, probably in order to prevent Karoba II from opening it.

It did not become clear which side was in the right. The quarrellers kept on accusing each other of meanness. Karoba section did not split

into two factions, the one including Karoba I, the other Karoba II for a number of Karoba I denied the correctness of the claims of the other members of their sub-section, and acknowledged the rights of Karoba II. The opposing parties were mostly referred to by the names of the constituent men, sometimes by the names of the sub-sections. The quarrellers asserted that they were not to visit each other any more. This prohibition was only partly effective. A number of Karoba II were absent from the wedding ceremonies for a daughter of one of the Karoba I, but some Karoba II attended. During occasional meetings animosity was not shown.

It seems that the Karoba I would have pressed their claim more if the matter had been of greater importance, for example if land had been regarded as scarce. Formerly the danger of these vaguely hostile relationships was that — supposing that a member of Karoba II had died after the making of the garden — the other members of Karoba II were apt to suspect that a wife or a (classificatory) sister of a Karoba I had worked *mum*. This might have led to serious quarrelling.

In other cases avoidance is achieved by moving away or discontinuing co-residence. For example Manggumbini, Komak and Arigunik moved away from Jiwaru's hamlet after they had quarrelled with him (see Case 9, pp. 95 ff.). Tiragop's father threatened to discontinue living with Wurirarange after the latter had prevented the killing of a Ngigamuli in retaliation for Tiragop's death (see Case 8, p. 95). The further events recorded in Case 9 show the inefficacy of such moves in bringing disputes to a close. The moves and avoidances mentioned so far entail loosening or breaking off cooperative relationships. They are often prolonged and express continued dissatisfaction with the other party in the relationship.

Sometimes people move to escape from further retaliation. For example, the Ngopare moved and settled among the Wanggulam after they had defeated their neighbours, killing two of them (see p. 79).

In other cases a move is intended to block the further course of events. For example, Mbabuarek disappeared after his stepdaughter (a daughter by a previous marriage of his third wife) had refused to marry the husband he had selected for her. People told me he had gone to Panaga, at a few days' distance. They said that the further wedding ceremonies could not be held in his absence. I got the impression that Mbabuarek had tried to put pressure on his daughter to change her mind. Two days later it appeared that he had not gone to Panaga, but had stayed in Mbogoga and had returned to his hamlet. The wedding

ceremonies took their normal course and the girl was married to the groom she herself had chosen. Among the Baliem Valley Dani similar moves or avoidances seem to occur. The Dani in this area hold pig-feasts at intervals of about three years. The date on which the feast starts is fixed by the dominant big man of the community celebrating the feast. Peters reports that in the case he witnessed this big man, named Kurelu, seemed to delay determining the opening date. For months rumours were circulating that the feast was about to start. In August 1963 two other important men started an introductory ceremony on their own initiative. This seemed to annoy Kurelu so much that he did not appear in public for a few days. People did not know where he was. After his return to public life he delayed opening the feast until 14 February 1964 (Peters; 1965, pp. 114-115).

Finally, a move may also occur when one of the parties in a dispute seems to be losing. He may then move because he has lost face and may want to avoid the presence of others. An example is provided by the next case.

#### CASE 15, MBABUAREK MOVES SOUTH OF THE KURIP

Mbabuarek, a Penggu, is a very enterprising young man. He has made extensive travels through Mbogoga and the surrounding areas. From one of his travels he imported the cassava, which — by 1960 — had become a favoured item of the diet. In the middle of 1960 he got on bad terms with Tibugwe, his first wife. His father had died at the beginning of that year, and he suspected his wife of having worked *mum*. Wuran, his classificatory brother, told me that Mbabuarek thought that she had killed his father by *mum* because a number of Karoba, among whom her brother, had been killed in a fight with people in the Lake Archbold area, whereas the Penggu had not suffered any losses on that occasion. (Later on Wandin led an expedition during which the Wanggulam retaliated for these losses; see Case 2, p. 79). Tibugwe was supposed to have been annoyed that the Penggu had come off so lightly and to have tried to restore the balance between the two allied sections by killing a Penggu.

People talked among each other about the way in which Mbabuarek treated his wife, they showed concern, but did not openly condemn his behaviour. After another beating the woman left for her father, and a few days later it almost came to a fight between Mbabuarek and his WFKB, Luki, who happened to pass close by Mbabuarek's hamlet. The two men were separated and an argument started. Luki said that his K+B and he did not intend to urge their daughter to go back to her husband who had beaten her so badly. He stuck to his argument and Mbabuarek did not get support.

A few days later it transpired that he had disappeared and had gone

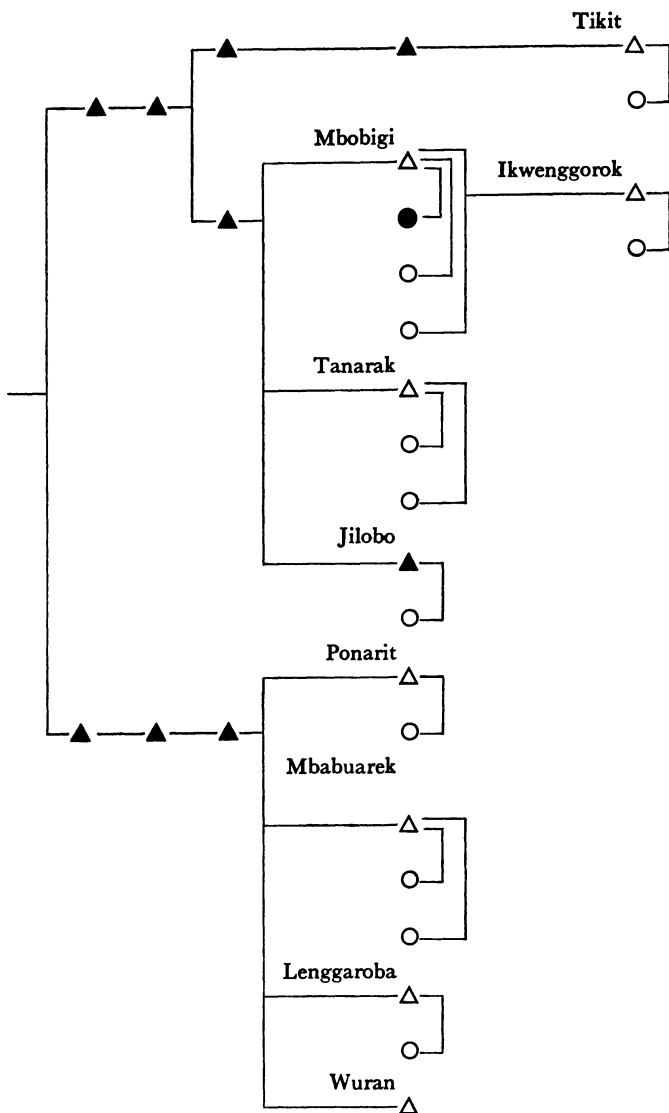

The genealogy shows only the adult male members of the sub-section with their wives.

FIGURE 9: MBABUAREK'S SUB-SECTION

to a deserted hamlet south of the Kurip (see Map V, H). The hamlet had been left by members of a foreign Penggu sector fearing an attack from the Wanggulam Penggu during the war in the beginning of 1960 in which the police intervened. In 1959 Mbabuarek's sub-section had made a swidden on the slope between the deserted hamlet and the Kurip, and in 1960 they made another bordering on the first one. Initially Mbabuarek lived on his own in the hamlet. A few days after I had noticed his disappearance, a number of Wanggulam men and I passed by the settlement. The gate was closed and Mbabuarek was busy on the yard, repairing one of the houses. He ignored us. People indicated him to me: 'Do you see, there he is'. It was clear that they thought him rather laughable. During the quarrels between Jiwaru and Arigunik sometime later I heard Jiwaru shout at Arigunik: 'Shut up, just as Mbabuarek did'.

During the following weeks Mbabuarek's wife joined him in his new hamlet. He was also joined by his +B, Ponarit, till then living in the same hamlet as his FK—B, Mbobigi. It was said that this move had been agreed upon some time ago, and that finally the whole of Mbabuarek's sub-section would go there. These moves formed only part of the expansion of Penggu mentioned on page 2; parts of other Penggu sub-sections also went to live south of the Kurip. It was said that the soil on the south bank was more fertile, and the men were to stay there for good. Mbobigi's —B, Tanarak, built a hamlet close to that of Mbabuarek, but Mbobigi himself did not. Instead, he planned to move a short distance away from his hamlet, which was becoming ramshackle. By the middle of 1962 rumours began to circulate that the other members of the section intended to return to the north bank. In 1960, just after Mbabuarek had left, his departure was consistently attributed to the quarrel with his wife's agnates. Later, however, it was linked with the arrangement with the other members of his sub-section. There was yet another possible motive for Mbabuarek's move: the man who left the hamlet in the beginning of 1960 had planted pineapple and pawpaw in the hamlet garden. Mbabuarek wanted to collect the profits from selling the harvest to the mission and government stations.

## 2. *Compensation payments*

The Wanggulam distinguish three types of compensation payments:

a. *awe*, for damage to material possessions and possessions in live-stock, particularly pigs. The payment Wonggimburu and his peers made after they had killed Wogogi's dog (see Case 6, p. 92) was called *awe*.

b. *ka*, for damages due to irregularities in marriage. *Ka* should be paid not only in cases of adultery, but also when a girl marries a man other than the one she had been promised to, or when she runs away from her husband. Mbobigi once told me he wanted compensation from Mbabuarek (see fig. 9) because the latter had married the widow

of one of their classificatory brothers. Mbobigi said he himself had been entitled to marry the widow, because he had contributed a larger amount to the bride price than had the new husband. He said he intended to claim compensation and he referred to the payment as *ka*.

c. *jowam*, for damages due to killings.

Sometimes, especially with small payments, people use the word *onggo*, that is to say 'payment', 'prestation in return'. *Awe* means 'seed'; 'to pay *awe*' is referred to in Dani as 'to plant seeds'. I did not hear the words *ka* and *jowam* in other contexts. *Jowam* is possibly a contraction of two words: *jao* and *wam*, referring to two of the main items of the payments. The men who pay *ka* or *jowam* are said to 'take' *ka* or to 'take' *jowam*; the recipients are said to 'eat' *ka* or to 'eat' *jowam*.

All three types of payments consist of one, or a few, or all of the items which constitute the wedding payments: odd cowrie shells, shell bands, *jao*, and pigs. The size of the payments differs greatly and ranges from one cowrie shell (for the theft of, for example, a stock of bananas) up to ten or even more pigs, together with a large number of shell bands and *jao*, for example 20 bands and even more *jao*, and finally a large number of odd shells.

As in the case of wedding payments, people contribute to and receive from compensations not only on account of ties of kinship and co-residence, but also as reciprocations of former prestations. The *jowam* taken by Luki after Ambenggonok's killing illustrates this point.

#### CASE 16, JOWAM TAKEN BY LUKI AFTER AMBENGGONOK'S KILLING

Luki brought the valuables making up the payment to the hamlet of Amianongga, who distributed them in the yard. Amianongga, a big man, was one of the closest male agnatic relatives of Ambenggonok. The transfer took place between 1950 and 1955 and people did not remember exactly how many items had been included in the payment. Accordingly the figures on Tables 12 and 13 do not tally. As far as I could determine the people who contributed to the payment included those mentioned in Table 12. The genealogy shows all the adult men living at that time on Karoba II territory. The list indicates the contributions these men have made, and it appears that a number of men did not contribute. I do not know why these people did not contribute. The two men at the bottom of the list are members of another section of Karoba, living in the Swart Valley. The two classificatory sisters' sons live in another Mbogoga parish. It was said that Luki had had many contacts with these people, but during my field work I did not notice any.

<i>Karoba II</i>		<i>pigs</i>	<i>s.b.</i>	<i>jao</i>
Katlangga	Ngobak $\Delta$	.	1	1
	Mbunarek $\Delta$	.		
Lamburoron	$\Delta$	.		1
	Luki $\Delta$	4	2	2
	Eaburak $\Delta$	.	1	
	Tarongga $\Delta$	1	1	1
	Kelele $\Delta$	.		
	Kwamok $\Delta$	.		
<i>associates Karoba II</i>				
	Agai $\Delta$	.		
	Lelok $\Delta$	.		
<i>Karoba I</i>				
	Mblogama $\Delta$	.		1
<i>foreigners</i>				
	Kawegawok $\Delta$	1		
	Lingirak $\Delta$	1		
	Kondenatlek $\Delta$	.		1
	Nolek $\Delta$	.		2
	sum	7	5	9

TABLE 12: CONTRIBUTORS TO THE *JOWAM* FOR AMBENGGONOK

<i>Karoba I</i>	<i>pigs</i>	<i>s.b.</i>	<i>jao</i>
△ Ngabengga △			2
△ Ngelopit △	1		
△ Amianongga △		1	
△ Ambenggonok △			
○ Karukenok ○	1	1	2
△ Tendet △			
○ Jemberat ○	1		
△ Lenggaroba △			1
△ Wuran △			1
△ Wandamendek △	1		
△ Luobarak △			1
△ Jambutitlek △			1
△ Awiambaga △			1
△ Wogogi △	1		
△ Ngunduarek △	1		
○ Mione △		1	a)
○ Autlen △			1b)
sum	6	3	10

a) Mione is a foreigner.  
 b) Autlen is a Wanggulam Penggu.

TABLE 13: RECIPIENTS OF JOWAM FOR AMBENGGONOK

Table 13 shows to whom the *jowam* was distributed: this genealogy does not represent the whole of Karoba I. As far as I could determine there are no recipients among the members not mentioned. Karukenok is the only full sibling of Ambenggonok. The items given to her children became a part of her and her husband's valuables, except for the pig given to her daughter who was already married. Ambenggonok's son, Tendet, did not receive from the *jowam* because he was still 'too young'. At that time he was in his early teens. He was brought up by Amianongga, who arranged his marriage in 1962. He did not have contacts with his mother.

The lists show that not all members of Karoba II contributed and not all members of Karoba I received compensation. At least it was explicitly stated that certain members did not contribute, or did not receive. Both contributors and recipients include non-agnates. These facts are an illustration of the limited role of the agnatic kinship groups and the force of the principle of autonomy. This principle is also expressed by the large amounts contributed by Luki, the organiser of the killing, and received by Ambenggonok's closest relatives, Karukenok and her children.

The *jowam* are much larger than the *ka*, which, in their turn, are larger than the *awe*. The size of *ka* depends in many cases on the size of the amount transferred as bride price. For example when a girl runs away from her husband who had given two pigs and a few *jao* as part of the bride price, her husband claims this amount from her father, or from her husband if she remarries. Wanggulam give inconsistent statements as to whether or not the former husband claims additional payments for 'immaterial damage' or for 'breach of promise' in excess of the material loss. (This actually happened in Case 13 when Kuranggen did not keep his word. See p. 136).

The idea of immaterial damage is not strange to the Wanggulam. Often they say that the injured party asked for compensation because he 'felt distressed'. Wogogi's actions against Wonggimburu and his friends (see p. 92) were not explained in terms of a big man extorting shells from a number of youngsters, but as the actions of a man in distress which justified a large compensation. People stressed that the dog had been of great use during hunts, so that Wogogi had been very attached to it. Even if he overplayed his sorrow, he tried to gain from the situation by feigning sentiments which Wanggulam feel constitute immaterial damage.

In the thoughts of the Wanggulam, *jowam* take a far greater place than other forms of payments, just as killings take a greater place than other forms of violence or other transgressions. The missionaries mis-

took the transfers of *jowam* for pigfeasts, and, according to the Wanggulam, they advised people to discontinue them. The advice was followed and hence I never witnessed such a transfer, the last being held in March 1960. Accounts of these events make clear that they have other functions besides redressing an imbalance between two groups of people. They are very festive occasions and the organisation resembles that of the pigfeasts. The pigs to be transferred are slaughtered and steamed on the morning of the transfer. The smoke of the fires rising from the hamlets is the final indication that the transfer is going to take place. There is no strict rule as to where this should occur: sometimes it happens on the territory of the injured party, but sometimes people dare not go there for fear they will be ambushed, so the injured party comes to collect the payment, or both parties go halfway. The transfer itself and the distribution which follows are very disorderly affairs. Many men turn up, often armed with spears and bows and arrows. Women come also, and, as for the main distribution of the pigfeasts, they wear the pigtusks and the fur caps of the men. One man has to lead the distribution, but people say that he is unable to command silence or to maintain order. The *jao* are put down in a long row with the shell bands on top of them. The most valuable *jao* are put down in the middle of the row, the less valuable at the ends. The leader of the distribution and his close relatives squat down halfway along the row of stones. I was told that it is impossible to keep guard of the stones at the ends. They are just grabbed away, and only the middle ones are transferred properly.

Mbobigi, describing the *jowam* for his younger brother Jilobo which he had distributed in the yard of his hamlet, said that he had not dared to keep anything for himself. He had given something to his eldest son, Ikwenggorok, who was unmarried at the time, and had felt that, if he himself had taken anything, people present were likely to think that he was keeping for himself valuables he should have handed out. A great many people had been present, the hamlet yard had been crowded, and a number had not been able to enter: they were outside the hamlet, or had climbed on top of the fences. Mbobigi enjoyed re-living the events in which he had been so important, but he said that he had been scared that somebody might have felt underpaid and started a fight, which, apart from bodily injuries, could have turned the hamlet into a ruin. He recalled another transfer at which this had actually happened.

Long dances follow the distributions, except when the transfer takes

place shortly after the killing, in which case people still feel hostile and fear an attack. Often, however, it is a long time before *jowam* is transferred. Several counter-actions may have taken place in the meantime, so that a corresponding series of *jowam* has to be transferred. This is what happened in the next case.

CASE 17. NGWEMBANIK VERSUS AMIANONGGA VERSUS MBILUMU

Before the Wanggulam were defeated by their southerly neighbours (that is, before about 1942, see p. 134) Ngwembanik, a Penggu, stole a pig from Wunika's father (see figure 10) to add the animal to the

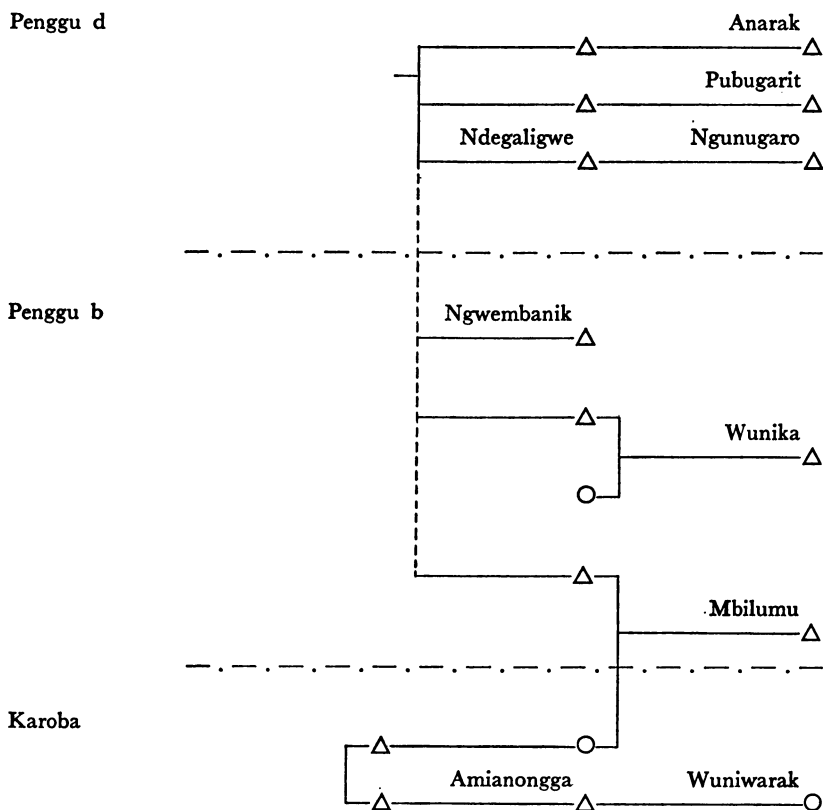

FIGURE 10: KIN RELATIONSHIPS NGWEMBANIK - ANARAK - AMIANONGGA - MBILUMU

price for his wife. Wunika's father repeatedly asked for compensation, but Ngwembanik did not pay. A few years later, during the stay in the Swart Valley, Pubugarit's father died. This man was also a Penggu, but he did not belong to the same sub-section as Ngwembanik. People associated the death with the pig theft and Ndegalgwe, the brother of Pubugarit's father, cut the ears of both Wunika's and Mbilumu's mothers. In both cases a great deal of blood was drawn and Ndegalgwe killed the women. These killings led to a large fight with bows and arrows, in which Penggu fought Penggu, both parties being joined by other people. There were no casualties. Amianongga, a Karoba, the F—BS of Mbilumu's mother, had been greatly distressed by the death of his classificatory sister and when, after the return to Wanggulam, Mbilumu's father died, suspicion arose that Amianongga's daughter had killed him. People did not hold him blameless in regard to his wife's death: he could have prevented the killing by offering *jowam* or by properly protecting her against assaults. The ear of Amianongga's daughter was cut, and with her too, blood was drawn. Amianongga promised *jowam*, and his daughter was not killed.

*Jowam* was given a number of years later, between about 1953 and 1958, in a sequence of three transactions:

1. Ngwembanik transferred *jowam* to Anarak, the younger brother of Pubugarit's father (Ndegalgwe had died). As Ngwembanik's theft had brought the two women to kill Pubugarit's father, Ngwembanik was held responsible.
2. Anarak transferred *jowam* to Amianongga. I neglected to ask whether Amianongga shared this *jowam* with Wunika, a feeble-minded bachelor. (During my stay he was Wandin's *eiloman*, see p. 80).
3. Amianongga gave *jowam* to Mbilumu.

The *jowam* were transferred on consecutive days, and they were of about the same size, but the constituent items were different. The most precious *jao* from Ngwembanik's *jowam* were used when Pubugarit and Ngunugaro (his FBS) were married. Mbilumu was not yet married in 1960-62 (see Case 7, p. 92). Throughout that time he was still holding on to the best *jao* he had received from Amianongga, so as to be able to raise a bride price.

The Wanggulam sometimes attribute a death to several acts of violence, for example to sorcery and to an injury in a former fight. In such cases more than one *jowam* may be transferred. This happened for instance after the death of Mbobigi's younger brother.

#### CASE 18, JILOBO'S DEATH

Jilobo was seriously wounded in a fight between the Wanggulam and he Weja-Mbamenggen, the main sections of Mbilu, the parish bordering Wanggulam in the east. This fight took place because Ngwembuk, a younger brother of Wandin, had committed adultery with the wife of a Weja-Mbamenggen. Jilobo died shortly after the

fight. His death was attributed to the wound, but also to a former wounding received in a fight with the Mbamenggen-Mbagawak, the main sections of the Tukobak, and, thirdly, to *mum* worked by the wife of his brother, Tanarak. I am ignorant of the motive for her working *mum*. The fight with the Mbamenggen-Mbagawak took place on account of pig stealings. As far as I know these started with Kwamok, a Wanggulam Karoba, stealing a pig from a Mbamenggen-Mbagawak. The latter retaliated by stealing a pig from Mbobigi who in his turn retaliated by stealing a pig from the Mbamenggen-Mbagawak. When this last pig was being cooked outdoors, a number of Mbamenggen-Mbagawak raided the people who had gathered for the cooking and in the ensuing fight Jilobo was wounded. Unfortunately a foreigner, the guest of Mbobigi and the other Wanggulam present, was killed during the fight. This man was also a Mbamenggen, but belonged to a section different from that of the raiders.

All these events took place before the Wanggulam were defeated by the Mbamenggen-Mbagawak and fled to Abena. *Jowam* were not transferred. After the Wanggulam had returned to Mbogoga, further violence took place; Mbobigi's —Z worked sorcery against Wogogi's son, killing him. Her alleged motive was to get retaliation for the death of Jilobo, her brother. She wanted to harm the Weja-Mbamenggen who had contributed to her brother's death, by killing Wogogi's son. This boy was the son of a Weja-Mbamenggen woman.

This last killing resulted in the transfer of a series of *jowam*.

1. Since Jilobo's death was partly the result of adultery committed by Wandin's younger brother, Wandin took *jowam*, transferring it to Mbobigi.

2. On account of *mum* worked by his wife, Mbobigi's brother, Tanarak took *jowam* and transferred it to Mbobigi.

3. Because he had started the pig stealings, Kwamok took *jowam* and transferred it to Mbobigi.

4. Mbobigi took *jowam* and transferred it to the Mbamenggen, to compensate the death of the Mbamenggen killed while he was Mbobigi's guest.

5. Mbobigi took *jowam* and transferred it to Wogogi to compensate for the death of Wogogi's son.

6. Weja-Mbamenggen took *jowam* and transferred it to Wogogi, also to compensate for the death of his son for which they were considered to be indirectly responsible.

Most of the transfers followed each other within a few days. Each of the men who took *jowam* was assisted by a wide range of relatives, while the recipient distributed the payments to a wide range of his relatives. Especially in the case of the *jowam* taken by Tanarak and transferred to Mbobigi, a number of people were 'giver-eater', that is to say they both contributed to the *jowam* and received from it.

When I talked to Wandin about this case, he denied that his subsection had had anything to do with Jilobo's death. When I asked why he had taken *jowam*, he answered that one of Mbobigi's wives or one

of his sisters might otherwise have worked sorcery. He added that some people, by unjustifiably asking for and receiving *jowam*, bring about their own death in some mystical way.

Case 17 shows the interconnection between *jowam* and wedding payments, which the Wanggulam themselves realise clearly. Togoli, a Penggu man, said, referring to the payment transferred to Mbobigi to compensate the death of his —B, 'We gave them a large number of valuables, *jao*, shell bands and pigs. That is how these people got their wives; Ponarit copulates, Mbabuarek copulates, Ikwenggorok copulates' (cf. genealogy on p. 142). The interest people take in the *jowam* is maybe partly due to this interconnection, and partly to the delight people have in large communal undertakings.

Mediation to fix the composition of the payments and to arrange the transfer does not often occur; Wanggulam say that one can use outsiders (as with the *awe* in the case of Wogogi's dog, p. 92), but that it is not necessary. To assemble a payment one may simply calculate how many *jao*, shell bands and pigs are needed in order to compensate all relatives of the person killed. Often it appears that some relatives have been overlooked and one has hurriedly to provide another *jao*, another shell band or another pig. Yet sometimes people still feel underpaid and more trouble ensues.

On the other hand just as with the wedding payments, the assembler often does not know beforehand who will contribute. I witnessed only one transfer of compensation, in this case of a *ka*. Just after people had left to transfer the payment, another man turned up and added a *jao*.

People are very sceptical about the effectiveness of a payment, most poignantly in the case of the *jowam*. Sometimes people take *jowam*, but nevertheless fear retaliation and flee. The Karoba did this in one of their quarrels with their easterly neighbours (see p. 137). They took *jowam* and retreated for a few years west of the Nganu.

People do not express disapproval when they talk about the renewal of disputes after transfers of *jowam*. They seem to regard this as the natural state of affairs. When asked why they transfer *jowam* at all, people say that it is possible that a transfer brings the troubles to an end, but that one can never be sure; one can make a mistake in fixing the composition of the payment, and the opponent can appear not to be satisfied. This attitude reflects the strong feelings of autonomy; one cannot know what the reaction of another will be. It is his affair whether he will be satisfied or not, and whether he will proceed to further retaliation.

Compensation takes place between people who live 'close' to each other. 'Close' in this sense means in practice that they live in the same parish or in neighbouring ones, whereas people living farther away usually do not compensate each other. While the Ngopare were still living in the upper Kurip area, 'far away' from Wanggulam, they killed a Wanggulam Penggu, a classificatory brother of Wandin. They did not pay compensation until after they came to Wanggulam. Wandin said that one of the reasons for allowing the Ngopare to settle in Wanggulam had been the expectation of a *jowam*.

Another sign of the weakness of group feeling, due to the predominance of the principle of autonomy, is that the procedure for settling a dispute does not depend on whether a member of a neighbouring parish or a full brother has been killed. In either case one takes *jowam*, proceeding in the same way. However, the size of the payments differs: inter-parish *jowam* tend to be larger than intra-parish *jowam*. When a man kills his brother, the killer himself has to provide the most precious items. He gives these to his closest relatives. The latter contribute the less precious items which are distributed to the distant relatives. This is called 'to do giver-eater'. For example, Arigunik contributed to the *jowam* taken by Perenatmendek, to compensate the classificatory brothers of his wife, Ngerenggaligwe, after her son had been killed by her co-wife, Tilubagatlak (see Case 1, p. 54). Arigunik is Perenatmendek's MZDS, but since he is also Ngerenggaligwe's K—B he also received part of the payment.

*Jowam* transferred after an intra-parish conflict, are larger than those transferred after an inter-parish conflict, because with the former a part of the parish compensates another part, and with the latter the whole of the parish contributes, whereas a number of outsiders contribute in both cases. Many more *jowam* are given in intra-parish quarrels than in inter-parish quarrels. In the 131 cases I have information about, 40 people were killed in intra-parish quarrels, but more than 102 in inter-parish quarrels. Following the 40 intra-parish killings 24 *jowam* were given, whereas following the 102 inter-parish killings only six *jowam* were transferred. Eleven people were killed by co-parishioners as a consequence of former killings, whilst almost all the inter-parish killings followed previous killings. These contrasts seem to indicate that within the parish people are more intent upon avoiding further violence by offering compensation than they are in fights between parishes.

### 3. *Supernatural procedures*

For the discussion of these procedures I refer back to Chapter 4, section II (see pp. 52 ff.), where I mentioned four methods:

- a. *mum*;
- b. *pulinggwe*, cursing of the (K)ZD;
- c. *aga polenggwe*, splitting of the tail;
- d. wilful destruction of own property.

All four methods are retaliatory; they follow infringements on one's rights. With all four the possibility exists that their outcome exceeds the initial offence.

I will not add to the discussion of Chapter 4, II, except for the description of a trouble case in which two of the supernatural methods of retaliation are applied and, secondly, the presentation of an hypothesis accounting for the existence of the beliefs in *mum*. I could not present this hypothesis in Chapter 4 since it is based on data discussed in Chapters 5 to 7.

#### CASE 19, ENGGAWAREK'S DEATH

A few years after their southerly neighbours had driven them from their Wanggulam territory, a part of Karoba section lived together with another section of their *anembeno* in an area about one day's travel to the east of Mbogoga. The Karoba got into trouble with their hosts after one of them, Enggawarek (see figure 11), committed adultery with the wife of his host. The latter got very angry, and to get his revenge he contacted men from the neighbouring parish. There was already dissatisfaction between the groups for several reasons. One of the Wanggulam Karoba had killed a member of this parish in an earlier battle, and this killing had not yet been paid for. The neighbours had another complaint: Luobarak, another Wanggulam Karoba I, had run off with a girl they had already promised to another man. In revenge the neighbours had killed a number of pigs of the Karoba, among them one pig of Mbaganarek and one of Wogogi, both Wanggulam Karoba I. The abduction had been followed by a bow and arrow fight, with casualties on both sides. The position of the Wanggulam Karoba had become rather uneasy after these troubles. Luobarak had fled to another section of the Karoba living in the Swart Valley, after Wogogi, a hot tempered man, had threatened to kill him.

Mbaganarek had the same host as had Enggawarek. He often went early in the morning to a sweet potato garden near the boundary with the neighbouring parish to look after his pig which was rooting out the swidden. To give the neighbours the opportunity for revenge, the host briefed them about Mbaganarek's whereabouts. Not long afterwards the latter was indeed killed in the swidden. When he did not come back, his younger brothers, Wogogi and Ngunduarek, went to the garden,

KAROBA I

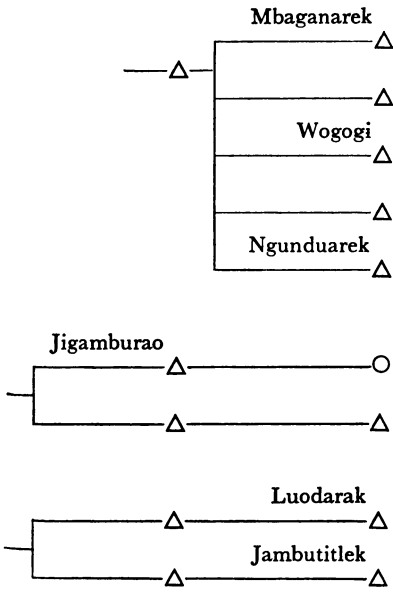

KAROBA III

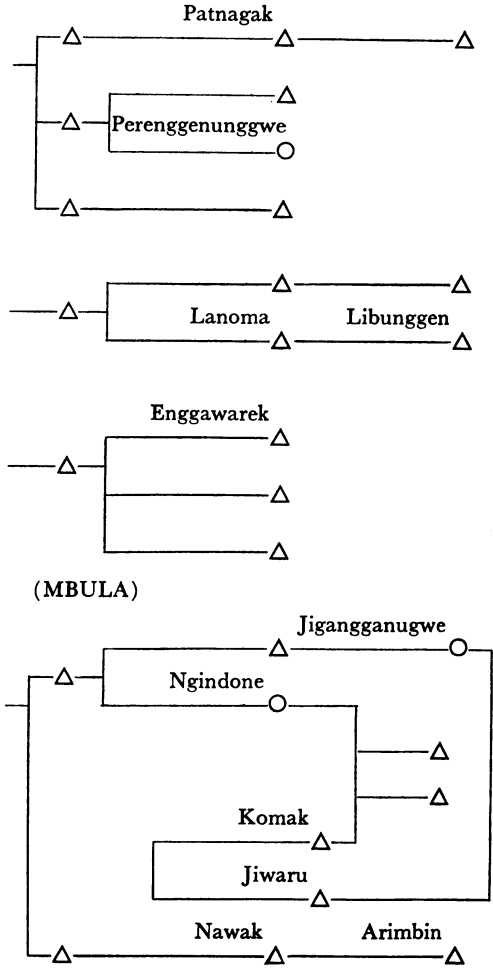

FIGURE 11: PARTIAL GENEALOGIES OF KAROBA I and KAROBA III

found the body, guessed what had happened, and in a surprise attack killed four people of the neighbouring parish. This led to a large battle which lasted several days and in which one of the Karoba III, Nawak, and two of their hosts were killed. The Wanggulam thought it unsafe to stay any longer: their hosts might try to take revenge on them. They returned to their former territory, Wanggulam. After some time Luobarak also returned there, and he offered *jowam* to

Wogogi and Ngunduarek. It was said that they had not asked him to pay, but that he was just afraid that they might try to get at him. It took Luobarak a long time to assemble the payment, but when it became known that he was really going to pay, Enggawarek (Karoba III) asked Wogogi and Ngunduarek (Karoba I) *jowam* to compensate for Nawak's death (Karoba III). Nawak had been killed in the fight waged in revenge for the killings committed by Wogogi and Ngunduarek, so that Enggawarek argued they were responsible for Nawak's death. The two brothers would have liked to answer that they had killed in revenge for their brother, Mbaganarek, and that Mbaganarek would not have been killed if Enggawarek had not committed adultery with his host's wife, so that Enggawarek had only himself to blame for Nawak's death. They did not dare to present this argument because, if they refused to pay, the wife or one of the (classificatory) sisters of Enggawarek was likely to work *mum* against them. So they paid Enggawarek with what they received from Luobarak.

One Karoba man got so angry with Enggawarek that he split the tail of one of the pigs killed for inclusion in the payment. This worked; not only Enggawarek, but also Patnagak, Lanoma, and Ono's wife died. The three men belonged to Karoba III and the woman was the wife of a Karoba III. The *jowam* was transferred in the period between 1956 and 1959. All deaths occurred before May 1960.

In the meantime Nawak's death had led to more violence. Jiganganugwe, his FBSD, worked *mum* against one of Luobarak's children, who then died. Her husband, Jiwaru, and Nawak's son, Arimbin, offered *jowam*. They did not dare to withhold it because of possible revenge by *mum*, though they could have argued that, since both sides had lost one member, there was no need for compensation. The *jowam* was transferred before Luobarak transferred his *jowam* to Wogogi. Notwithstanding the payment, Luobarak's wife took revenge: she worked *mum* against the infant child of Ngindone (Jiganganugwe's F—Z and simultaneously her H+BW). Luobarak did not offer *jowam*, allegedly because the missionaries had urged people to abandon the payments. This part of the case was told by Jiwaru's +BS. He said that further action would not be taken as the Wanggulam had done away with violence and warfare.

The split tail was not the only cause of Enggawarek's death. His brother had joined an expedition of the neighbouring parish to the west and was killed. Enggawarek asked the neighbours for *jowam*. He received and distributed it, but kept too much for himself. One of his classificatory sisters, Perenggenuggwe (Karoba III), got angry with him and worked *mum* against him. He died and his close agnates asked for *jowam*, but did not get anything, either from Perenggenuggwe's +B, himself a Karoba III, or from her husband, who is a member of a group living west of Wanggulam. The outcome was that Enggawarek's MKBD, the wife of a Wanggulam Karoba II, worked *mum* against the 'younger brother of Perenggenuggwe's son' (this formula renders the Wanggulam way of tracing the relationship), while

he passed through Wanggulam territory. The man died in 1961, and after that there was no more violence.

There was yet another cause for Enggawarek's death. The wife of Libunggen (Karoba III) had been abducted by Jambutitlek (Karoba I and Luobarak's F—BS). Enggawarek thought that Mbologama (Karoba I) had incited Jambutitlek. To retaliate Enggawarek stole one of the pigs of Mbologama's F+B, Jigamburao. This pig was tended by the latter's daughter, who thereupon worked *mum* against Enggawarek and killed him.

Apart from the application of supernatural means of retaliation, the case shows a number of other points:

1. In the first part of the case, when members of different parishes fight each other, people use physical violence; in the second part, when people of the same parish are quarrelling, supernatural methods are used. This demonstrates the inclination to avoid open quarrels and disruptions within the parish, notwithstanding the occurrence of serious discord.

2. There is no mention of big men trying to act as mediators; this is consistent with their limited role. By 1960 Wogogi had become a big man, but at the time of Mbaganarek's killing he was still in his late twenties. Nevertheless, he went with his brother Ngunduarek (then in his early twenties) to seek revenge for their elder brother, without being supported by a big man. Although Ngunduarek did not mention that he was afraid of Enggawarek's fighting ability, this may have been of influence in inducing him and Wogogi to pay *jowam*. Enggawarek was the biggest man among the Karoba III. Probably he was a war leader. Ngunduarek admitted, that Luobarak offered *jowam* for fear that Wogogi or Ngunduarek himself would try to harm him.

3. The great influence of *mum* is apparent; the case shows that *mum* not only induces people to act in accordance with cultural standards, but also presses so hard on people that they are prepared to be blackmailed in order to escape it. Later the blackmail may lead to further violence.

4. The case demonstrates the inefficacy of *jowam* as a means of finally settling a dispute.

5. It shows further the way in which an inter-parish conflict (as between Karoba and their neighbours) can develop into an intra-parish conflict (as between Wogogi and Enggawarek) or into an intra-sub-section conflict (as between Wogogi and Luobarak). The extensions of responsibility underlying such developments will be discussed below.

6. One event may be regarded as a link in several chains of retaliation.

In the beginning of Chapter 5 I argued that the principle of autonomy applies to all adults, whether men or women. The discussion which followed on governmental principles was mainly concerned with men and with men only.

Notwithstanding their autonomy women are in several respects in a less favourable position than men. Women have much less opportunity of gaining prestige and competing for leadership than men. They have no weapons, so they cannot prove themselves to be good fighters. Their work is a daily routine and unlike the work of men does not lead to spectacular feats such as the felling of giant trees or the building of a large fence in record time. Women do not have many occasions on which to get into a central position, for they do not organise work parties or harvest feasts; they give their advice when they are alone with their husbands; or — in public — in whispers. They have less opportunity to show off by witty remarks or public announcements.

The structural inequality between men and women produced by the marriage regulations is perhaps the most important. Groups of men exchange women, who on marriage have to leave their natal group to join the section of their husbands. On the morning of the day when she will be dressed in her wedding skirt, the bride is suddenly caught by her brothers or classificatory brothers. She has not been informed of the forthcoming marriage and usually she screams and cries, and tries to wrench herself free and to prevent herself from being dressed in the skirt. Although a girl is able to reject the man her parents wish her to marry, a rejection may bring her much trouble. Her parents may try to force her to accept the man they want. Although they may use physical force during these efforts, I heard of several cases in which a girl had stuck to her rejection.

Although women are equal to men in terms of the autonomy principle, they do not enjoy the benefits of the leadership principle and are unequal in terms of the principle of partnership. This situation might underlie the beliefs in sorcery. By means of *mum* women can partly overcome their disabilities. *Mum* is regarded as the female weapon, bows and arrows and spears as the male weapons. A Wanggulam myth states that women formerly possessed bows and arrows. As they were no good in the use of arms, the men robbed them and used the weapons ever since, and with great success. To overcome the loss, the women

took to *mum*. Leadership among the men is open, and so is the possibility of recourse to *mum* among the women: all women are believed to be capable of working *mum*.

*Mum* is an important factor influencing the actions of the Wangulam. Moreover, in the same way as men gain prestige through fighting ability, women gain prestige from success with *mum*. A woman who is reputed to have killed a great number of people is said to be a 'big woman'. When a woman shows other qualities big men have, for example when she displays verbal skill while commenting in public on proceedings, this is an indication that she is big, that is to say that she is a good worker of *mum*. Only few women did in fact comment in public. It is said that formerly women tried to influence decisions concerning warfare. Only big women took such action. However, I heard of only two occasions on which this had happened and both times the advice of the women had not been followed.

*Mum* does not make up for the women's inequality: it does not overcome the inequality implied in the marriage regulations, and a successful fighter attains a higher status than a successful worker of *mum*. Although *mum* is sometimes worked against members or associates of other, hostile parishes and people then benefit from it, *mum* is in disrepute with both men and women. It is seen as a threat, since it is worked secretly and in silence, and people do not know how to defend themselves against it. They are always on their guard to evade women who might have a grudge against them. During the period from about 1935 until 1960, 12 people were killed in intra-parish fights, while at least 20 deaths were attributed to *mum*. In almost all these cases a woman had been convicted because her ear had been cut and it had bled. People told me about a number of other cases in which they suspected a woman, but were not sure. I was told that there were very many of these cases, but that people kept them to themselves. Formerly, before the arrival of the Europeans, such cases were a frequent source of trouble, as people tried to kill one of the close relatives of the woman during a battle, or tried to capture the woman and to cut her ear, in order to be able to ask afterwards for compensation.

#### 4. *Fighting*

The fourth method to redress an imbalance in a relationship is fighting. Several types of fights can be distinguished: (a) raids, (b) sudden outbursts of fighting, and (c) battles.

a. *Raids* are premeditated attacks on persons, made mostly in

surprise by a small group of men, usually three to six in number, but sometimes larger or smaller. Men daring enough to make a raid unaided are greatly admired. Raids take place both in intra- and in inter-parish conflicts. In the latter case the group may have to go a considerable distance, using the jungle on the upper slopes of the mountains. Sometimes the group spends a few days and nights on the trail. The actual attacks are often made during the night.

Mbogondini Dani fighting practices are not chivalrous according to Western standards. Raids are often made on women working in their sweet potato gardens. It was said that a good method of killing visiting foreigners is as follows. A group of men arranges that one of them invites for a meal a foreigner who has come to Wanggulam, for example to attend a wedding or another ceremony. The others fetch their weapons and hide near the path along which the host will guide his guest when the latter goes home after the meal. Near the hiding place the host seizes his guest, and the friends make their appearance and kill him. Although Wanggulam told me that such killings occurred often, I did not come across one in any of the case histories. The following case gives an example of a raid.

#### CASE 20, NGWEMBANIK KILLS ENGGANGGOK

Engganggok was originally a foreigner living in the upper reaches of the Kurip. After troubles with a neighbouring parish he had fled to Wanggulam where he associated with Karoba II. He was a son's son of a Karoba II woman. His former neighbours, the Mbagawak, asked Ngwembanik, a Wanggulam Penggu, the son of a Mbagawak woman and a big man, to kill Engganggok for them. They gave Ngwembanik a spear with which to kill him. The latter hid the spear in the house of his wife. He did not want to keep it in the men's house lest other men would notice, and possibly tell Engganggok. He told his wife that he had just bought the spear for a number of cowrie shells.

Not long after he had got the spear, Ngwembanik went to kill Engganggok. On his way he met Wandin, whom he informed. Wandin went with him. They found their victim on a lookout together with a foreign Karoba member. The latter was greasing and plaiting Engganggok's hair. After Ngwembanik had left his spear in the bushes nearby, he and Wandin went to the men and greeted them cordially, shaking hands. They squatted down, nervous at the prospect of killing a man. After a while Ngwembanik got up and got his spear which he drove into Engganggok's skull. While Wandin finished him off, the dying man's companion ran away to get his bow and arrow. He managed to hit Ngwembanik while the assailants tried to get away. People say that a man who has just killed is not much of a fighter: 'He has the dead man's spirit on his guts'.

Wogogi heard the same day what had happened. He was Enggang-gok's MKB and threatened to fight Ngwembanik. Ngwembanik fled into the jungle, where he spent the night. A number of Karoba II men quietened Wogogi (although they had been Engganggok's hosts) arguing: 'Engganggok's co-parishioners kill us, so grant that we kill them'.

The Mbagawak rewarded their KZS, Ngwembanik, with a number of *jao* and shell bands, and offered *jowam*. The payment was transferred in Engganggok's original residence. Wogogi and his younger brother Ngunduarek attended, and each received a shell band. Wogogi's elder brother did not go, 'therefore' he did not receive from the *jowam*.

Noteworthy is that the Mbagawak form one of the main sections of the Tukobak, who are on bad terms with the Wanggulam. They forced the Wanggulam to retreat to Abena and later drove them still farther from Mbogoga. After the Wanggulam had returned there, there had been at least one other fight between the two groups, and on this occasion the Wanggulam had been victorious, (see p. 79). However, the bad relationship between the two groups did not prevent Ngwembanik (Wanggulam) from helping his mother's section (Tukobak).

b. *Sudden outbursts of fighting occurring after minor offences.* Sometimes abuse is followed by a scuffle which turns into a fight with bows and arrows. These outbursts are often the result of raids aimed at stealing a pig or a pandanus fruit. They are mostly intra-parish fights, and the number of fighters is always limited. The following case is an example.

#### CASE 21, KONDAGA TRIES TO MARRY HIS DAUGHTER TO LEMBIAGOP

Rumours circulated that Kondaga, a Penggu, one of the biggest Wanggulam, intended to marry his daughter to Lembiagop, a Ngopare. He did not make any arrangements, however. Lembiagop did not want to marry the girl and on the morning that she was dressed in her wedding skirt he fled from Wanggulam. At the end of the morning Kondaga sent a piece of pork to Lembiagop's hamlet. The latter's classificatory brothers brought it back. Kondaga, stubborn, brought it again to Lembiagop's hamlet. The classificatory brothers brought it back again. Kondaga got angry, and with his classificatory brothers and (classificatory) sons he went to Lembiagop's hamlet where a stick-fight developed in which no serious injuries were inflicted. Kondaga gave up his efforts and tried to marry his daughter to Erimawe whom the girl did not like (see Case 3, p. 83). Lembiagop returned after a few days. I suggested that Kondaga had not arranged the marriage beforehand and was so stubborn because he was a big man and wanted to force his will upon the Ngopare who were Penggu's guests. People denied that my supposition was correct.

c. *Battles* are mostly large scale affairs. When people hear that a fight is going on, or is likely to be resumed, they gather in great numbers,

'grateful' for the occasion, and they join the fight. A fight in Mbogoga attracts men from over the whole of the valley, and even from neighbouring valleys, so that finally members of several parishes may take part although the fight was begun by people from two parishes, or by sub-groups of one parish. Groups often split on reaching the field of battle and join both sides. People feel that, if they do not split, the balance is upset. Later the destitute party complains: 'Why did you all have to join our opponents?' 'Couldn't you split?' Battles may last for several days. They are adjourned or ended by proclamations yelled by big men or by the closest relatives of the man killed during the battle.

People say that they fight in waves: first the young men (of age 15-25) fight. Older men (age 25-30) supersede them: the still older men squat down, and look at the performance of the younger men, performing *amulok kunuk*.

Accounts of other aspects of the battles supplement this picture, which does not fit in completely with the accounts of the introduction of young men to the battlefield (see p. 81), which state that father and son fight alongside one another. But these accounts also mention that the other men look on to see the performance of the youngster. It may be that the waves are not completely separated and overlap to a certain extent. It seems also that the battlefield is larger than the first accounts imply. The Wanggulam say that, when a man meets a close relative on the battlefield fighting in support of his opponents, he does not fight him but, on the contrary, tells him where the main forces are, lest his life be endangered. When a small man notices a big man belonging to the other party, he tries to escape, lest the big man kills him. The last two items give the impression that people often fight singly. The same impression is created by the information that the yells of the big men reach the men fighting 'here and there in the fields'.

Battles are fought in full panoply: fur strips, adorned with feathers and plumes on the head; coats of mail, adorned with feathers and orchid fibre; pig tusks in the nose; bundles of cassowary feathers hanging on the wrist. In order to keep the fur of the strips shiny, they are usually stored wrapped up in covers of pandanus leaves. It is said that during battles small boys look on holding the covers so that if rain starts the strips can be put away, lest they lose their shine (compare Matthiessen; 1962, p. 11). Women also look on, but people say that battles are not the best occasions for men to show off and impress women.

It seems therefore that there is one centre of fighting where men fight in groups while at some distance men are roaming the fields on their own trying to get into contact with the enemy. In many ways these battles seem to resemble tournaments (compare Pouver; 1962, p. 12), but they are not merely shows: the bitterness of the fighting varies with the fighters. 'Principal fighters', the persons directly concerned with the quarrels resulting in the fight, fight harder than 'secondary fighters' who have joined later. Wanggulam say that such people fight *wetlek*, 'for nothing' (see p. 101). Several factors complicate the situation. Different people may pursue different ends in one and the same battle, as Case 22 shows.

CASE 22, NGOBAK AND MBUNAREK TRY TO KILL JIKWANAK

Among the Mbamenggen-Mbagawak, Wanggulam's southerly neighbours, troubles started when Engginduk, one of their big men, died. It was suspected that a woman married into Mbagawak section had killed Engginduk because he had failed to return the pig she had contributed to the price for one of Engginduk's daughters. The girl had left her Mbagawak husband shortly after her marriage.

Engginduk's sons caught the woman. Her ear bled heavily after they had cut it. Enraged, the men killed the woman. This led to a fight growing into a battle in which four people were killed, two on each side. The Wanggulam joined the fight on both sides, but did not kill. Ngobak and his younger brother Mbunarek (see figure 8, p. 126), made an effort to kill Jikwanak, a Mbamenggen-Mbagawak, the man who had organised the raid in which their father, Katlengga had been killed. *Jowam* for this killing had been transferred. The two brothers fell upon Jikwanak and wounded him seriously, but did not succeed in killing him.

It is important for men to remember when joining a battle which enemies may be present on the battlefield. If they forget, they are soon dead. The more people one kills, the more efforts at retaliation one has to face, and this is probably the reason that excessively warlike men are believed to die early. When people are killed during a battle, the fight may take a different turn. The Wanggulam joined a battle fought in the upper Kurip area in the late 1930's. They split and joined both parties. After one of the Wanggulam had been killed, they all united, fought both the original contesting parties, and inflicted such heavy losses that the latter fled to the Swart Valley.

On raids, during which a small group of men fight in order to retaliate, there are no secondary fighters and the element of display is accordingly much less prominent. Raids are often waged in the dark,

and the fighters do not wear battle attire. Women do not look on, but flee as fast as possible.

Especially with sudden outbursts of fighting, motives are often slight. Mbobigi and his younger brother, Tanarak, had a bow and arrow fight after the latter had accused Ikwenggorok and Erimawe, Mbobigi's S and his ZS, and at that time both still boys, of having stolen pork. In a few other cases a bow and arrow fight between full brothers started over the distribution of a ceremonial payment. I heard about 26 intra-parish bow and arrow fights. During these fights 13 people were killed. Fourteen fights ended without anybody being killed.

I doubt whether in all the small scale fights people intend to kill when starting the fight (compare Matthiessen; 1962, p. 39). Wanggulam told me that after a wronged husband has heard about adultery committed by his wife, a bitter fight on the following lines is likely. The wronged husband seizes his bow and arrows and tracks the adulterer down. The two men start a fight during which they get so close that the points of the arrows touch. Tension may become so high that the men beat each other with the bows. I heard about only one case in which this had actually happened. These accounts give the impression that the men have an opportunity to kill each other but do not use it. It seems to me that the main purpose of the fights is to demonstrate the bravery and manliness of these men who dare to menace each other at such close range, although neither can be sure that the other does not intend to kill him.

Outside responsibility and internal obligations do not complement each other. Suppose a Wanggulam Penggu kills a member of a neighbouring parish, after which the neighbours kill a Wanggulam Karoba in retaliation. The imbalance between the parishes is redressed, but the balance between the main sections of Wanggulam is disturbed.

With reference to the second killing, the neighbours are said to be *ndok*, that is to say, they actually killed. Penggu is *ngelen*, that is to say, it caused the neighbours to kill. With reference to the first killing, Penggu was both *ndok* and *ngelen*. Penggu is considered to have caused the second killing and has to offer *jowam* to compensate Karoba, in addition to the neighbours having to offer *jowam*. The responsibility for a killing, a death, or an injury, is extended in other ways: when A has invited B to go with him on a trek and B dies on the trail, A has to offer *jowam* (see Case 12, p. 134). Other possibilities are mentioned in the cases Arigunik versus Jiwaru (see p. 101) and Enggawarek's death

(see p. 156). Jiwaru claimed compensation from Komak for the grief suffered on account of the wounding of their father. His argument seems to have been: 'That Komak's wife was stolen was an affair between him and the thieves. It was not my business. Nevertheless I am grieved by it, since my father has been wounded. So he has to compensate me'. In the other examples analogous arguments can be applied.

The extension of responsibility entails that quarrels are easily prolonged and that they arise between groups which have been co-operating, so that for example an inter-parish conflict turns into an intra-parish conflict.

Although mission preaching and conversion to Christianity make them say that fighting is bad, Wanggulam still get enthusiastic when describing fights and they give dramatic and often amusing accounts of what happened. Killing as such has a great appeal for the people. When an enemy has been hit and is dying, his opponents gather and kill him off. It is said that a killed enemy was often covered with arrow wounds. All assailants, whether they had inflicted the main hit or one of the minor ones, claim responsibility for the killing. This is called a 'hot killing' and all assailants can justifiably add the feat to their battle record. After the killing a number of people might hit the corpse. These people merely 'heat up cold food'. This is not regarded as a real killing. To kill somebody by oneself, or with one arrow, is a source of pride. In the accounts of fights it is mentioned emphatically.

During the description of Case 20, 'Ngwembanik kills Enggangok', it became apparent that Wanggulam go through great emotional upheavals before and during the killing. It is said that when a man is about to kill he sweats profusely, he is *aganak*, a word usually indicating 'scared' or 'afraid'. Its general meaning seems to be 'to be put out', but in the context mentioned above the word cannot be translated as 'afraid'. A man who does not know this emotion, does not kill, so people say: '*ap kulitluk, inaganak lek*'; which literally translated means: 'the cowards, they are not afraid'. After the fight the killer feels his strength sapped. He goes to his men's house, and sits down, exhausted.

Tentatively I would explain the appeal fighting and killing has for the Wanggulam by asserting that they like to demonstrate their superiority, notwithstanding the equality implied in autonomy, and thus to overcome it. The tendency to reject the notion of equality is acknowledged in the recognition of the superiority of the big men. People admire them greatly for their ability to fight better and to make better plans than others. It is also expressed in the eagerness with which

people impose disagreeable jobs on feeble-minded men and in the way they tease them. It might also be expressed in the inclination to lie; by lying one keeps oneself better informed than others, one fools the others, and thus is superior to them. Killing is a clear proof of the superiority of the killer, and by joining a fight a man demonstrates that he is prepared to put to the test his superiority over other men. That is to say, he pledges his superiority.

Although the fights serve to redress an imbalance, the participants aim at gaining prestige. In trying to achieve the latter, they disregard the former, so that although in theory every fight can make an end to further fighting, in practice fighting goes on and is continually renewed. People realise that wars are endless affairs. They refer to fighting between the parishes as *ndogwe mbanggwe*. This expression resembles the expression *wone mbanggwe*, which literally translated means: 'to cut (*mbanggwe*) talk (*wone*)'. The expression seems to indicate a series of remarks and stands for 'to discuss', 'to chat'. In analogy *ndogwe mbanggwe* might mean: 'to cut *ndok*', indicating that a number of people one after the other is *ndok*, as the result of a series of killings.

The fights go on in the open, but a great many acts of retaliation go on in secret, only to be revealed by deaths attributed to *mum* and other supernatural causes. Especially within the parish, deaths are believed to be caused more frequently by supernatural methods of retaliation than by fighting. In the preceding discussions a number of reasons have been mentioned to account for the magnitude of the violence present in Wanggulam society:

- a. the absence of men wielding the power and authority that would enable them to check their co-parishioners;
- b. the impossibility of matching the outcome of several means of retaliation to the magnitude of the initial breach of norm;
- c. the lack of mediation in fixing the size of compensation payments;
- d. the imbalance created between sub-groups when, during their common fight against another group, an act of retaliation is perpetrated on one sub-group though the initial breach of norm was committed by the other.

To these should be added the attraction offered by killing and fighting. This resulted in the retaliation often exceeding the number of initial killings. This happened for example in Case 19, 'Enggawarek's death', when Wogogi and Ngunduarek killed four people after their elder brother had been killed. On the expedition to the Lake Archbold

area (see p. 79), in revenging the killings of seven or eight of their co-parishioners, the Wangguam killed at least 14 people.

While I stayed among them, Wanggulam gave me the impression of having disliked the insecurity that resulted from the efforts of adult men to become or to remain big. Because retaliations often exceeded former breaches in severity, there were almost always imbalances still to be redressed. A number of men told me about the killings to which their close kin had been victims and which still went unrevenged. The men often suspected close relatives or co-residents of having had a hand in the deaths. Every death added to the suspicions. People told me about these cases in whispers. They said that it had been a bad situation in which nobody had been sure he did not run the risk of being killed in retaliation for another killing which might have happened a long time ago and which he might have forgotten about. People said that they had now done away with fighting for good, and that their children would not know about it. They professed to be glad that the continuous insecurity had come to an end and maintained that the discontinuation of fighting had come as a relief to them. Their demeanour while saying so made me believe they were sincere in this respect. Yet killing and fighting itself had not yet lost its appeal, as witness the delight people took in bringing up old cases of trouble. It might be therefore that after a number of years of peace, and the memory of the insecurity of former times faded, the urge to fight will grow and will lead to renewed outbursts of violence.

## CHAPTER 9

### CONCLUSION

Smith's paper which I partly expounded at the beginning of chapter 5 is one of the studies of lineage structure stimulated by 'African Political Systems' (in the following discussion I refer to this book as A.P.S.). In the Preface to A.P.S. Radcliffe-Brown defined political organisation (the concept he uses where Smith uses 'government') as: the maintenance or establishment of social order, within a territorial framework, by the organized exercise of coercive authority through the use, or the possibility of use, of physical force (Radcliffe-Brown; 1940, p. xiv).<sup>1</sup>

Radcliffe-Brown's definition has been criticised by several writers. Easton (1959) dislikes it on two grounds, firstly because it holds that in studying government we have to deal with 'particular structures', whereas, in Easton's view, 'political relationships could be simply viewed as an analytic element in society' (Easton; 1959, p. 216). Easton's second objection is that the definition implies that government proceeds by relying on at least the possibility of the use of physical force (Easton; 1959, p. 217). To support this criticism he quotes Schapera's analysis of Bushman government in 'Government and Politics in Tribal Societies' (Schapera; 1956). The latter had also proposed an alteration of Radcliffe-Brown's definition. Schapera wrote:

organized force is only one of the mechanisms making for orderly life in any community, and to adopt it as the distinctive criterion of political organization would mean neglecting unduly the various others that help to unite people into self-governing groups. It is more useful, I think, to base our definition on function and not on means and to regard political organization as 'that aspect of the total organization which is concerned with the establishment and maintenance of internal cooperation and external independence' (Schapera; 1956, p. 218).

It should be noted that Schapera not only shifts from means to function to define government, but also that he grants government a more

---

<sup>1</sup> Smith's terminology is at variance with most of the writers I will quote. Several times I will have to use the same terms Smith uses but defined in another way. When this is the case outside of quotations, I will indicate the terms with quotation marks.

embracing function than Radcliffe-Brown did, since the latter wrote: 'In dealing with political systems, therefore, we are dealing with law, on the one hand, and with war, on the other' (Radcliffe-Brown; 1940, p. xiv). This makes more understandable the use Radcliffe-Brown made of force as a part of his definition of government: action against offenders or against outside aggressors seems to call for the use of force more than does the maintenance of internal cooperation.

In their Introduction in A.P.S., Fortes and Evans-Pritchard 'carefully sidestepped' (Easton; 1959, p. 218) the definition of 'political organisation'. It would seem that they were not prepared to accept Radcliffe-Brown's definition since among several of the peoples studied in A.P.S. no organised exercise of coercive authority was found. If Fortes and Evans-Pritchard had accepted Radcliffe-Brown's definition, they would have been forced to conclude that these peoples lacked government, a conclusion they apparently were not prepared to accept. Instead they set out to discover what 'in the absence of explicit forms of government could be held to constitute the political structure of a people' (Fortes and Evans-Pritchard; 1940, p. 6).

Fortes and Evans-Pritchard divide into two groups the 'political systems' analysed in the book they edited. They call the one group 'states',

those societies which have centralized authority and administrative machinery, and judicial institutions — in short, a government — and in which cleavages of wealth, privilege and status correspond to the distribution of power and authority (1940, p. 5).

and call the other group 'stateless societies',

which lack centralized authority, administrative machinery, and constituted judicial institutions, — in short which lack government — and in which there are no sharp divisions of rank, status or wealth (1940, p. 5).

Later they suggest that all societies can be classified into three types. Firstly

there are those very small societies . . . in which even the largest political unit embraces a group of people all of whom are united to one another by ties of kinship, so that political relations are coterminous with kinship relations and the political structure and kinship organizations are completely fused (1940, pp. 6-7).

The second and third types are respectively stateless societies and states. In stateless societies 'a lineage structure is the framework of the political system, there being a precise coordination between the two' (1940, p. 7). In such societies, Fortes and Evans-Pritchard assert, the balance of forces, and thus stability, rests with the 'spatially juxtaposed and struc-

turally equivalent' segments defined in 'local and lineage . . . terms'. The stabilizing factor is not a superordinate juridical or military organization, but is simply the sum total of intersegment relations' (1940, pp. 13-14). Evans-Pritchard adds to this in the 'Nuer':

Each segment is itself segmented and there is opposition between its parts. The members of any segment unite for war against adjacent segments of the same order and unite with these adjacent segments against larger segments (Evans-Pritchard; 1940a, p. 142).

He and Fortes called the principle underlying such a structure 'the segmentary principle'. Later, because of its implications of contra-position and of super- and subordination, Smith gave this principle a central place in his theory. Evans-Pritchard and Fortes realised that its occurrence was not restricted to stateless societies displaying a lineage structure. In his analysis of the Nandi-speaking peoples, who are stateless and who also lack a polysegmentary lineage system, Evans-Pritchard argues:

In a structural classification of the people of East Africa the significant features of these four societies are: a segmentary territorial system with a political organization based on a territorial principle (Evans-Pritchard; 1940b, p. 266).

Fortes argues that 'it is quite possible for the subdivision of a centralized state to have a segmentary social organization' (Fortes; 1945, p. 263).

The recognition of the role of lineages in government led to a great deal of research. As a result it appeared that the typology proposed in A.P.S. was too simple. The existence of intermediary types was brought to light and several attempts were made to revise the typology (e.g. Bernardi; 1952, p. 331, Middleton and Tait; 1958, pp. 2-3, and Barnes; 1954, p. 56).

Smith's theory transcends these efforts by taking the analysis to a more abstract level. His system of concepts, as stated in the beginning of Chapter 5, purports to provide the criteria by means of which any type of government can be placed on a continuum, thus eliminating the 'spurious' dichotomy of states versus stateless societies. He criticises Fortes and Evans-Pritchard for trying to explain lineage organisation partly in terms of locality, partly in terms of the principles of unilineal descent and affiliation. Smith calls this 'explaining the myth by itself' because it does not refer to 'the function which the units are constituted to discharge'. In other words, lineage organisation cannot be understood in terms of lineage ideology alone, since it is the dependent variable,

variable in respect of its governmental functions (Smith; 1956, pp. 69-70). In Smith's view lineages combine political and administrative functions as defined by the genealogical charter which expresses their mutual relationships (Smith; 1956, pp. 52-53). For instance, two minor lineages making up one major lineage, are in a political relation of contraposition to each other and in a subordinate, and hence administrative, relation to the major lineage.

In his further analysis Smith considers that the degree of combination of political and administrative structures within particular governments is a crucial characteristic in comparative studies (Smith; 1956, pp. 67-68). Since I use his theory only for the analysis of Wanggulam government, I do not use this part of his theory.

Smith's analysis of segmentary lineage systems does not seem correct to me and I would like to demonstrate its incorrectness using as an example Evans-Pritchard's analysis of the Nuer system. The latter writes:

A tribe is divided into territorial segments which regard themselves as separate communities. We refer to the divisions of a tribe as primary, secondary, and tertiary tribal segments. Primary sections are segments of a tribe, secondary sections are segments of a primary section, and tertiary sections are segments of a secondary section . . . A member of Z2 tertiary section of tribe B sees himself as a member of Z2 community in relation to Z1, but he regards himself as a member of Y2 and not of Z2 in relation to Y1. Likewise, he regards himself as a member of Y, and not of Y2, in relation to X. He regards himself as a member of tribe B, and not of its primary section Y, in relation to tribe A.

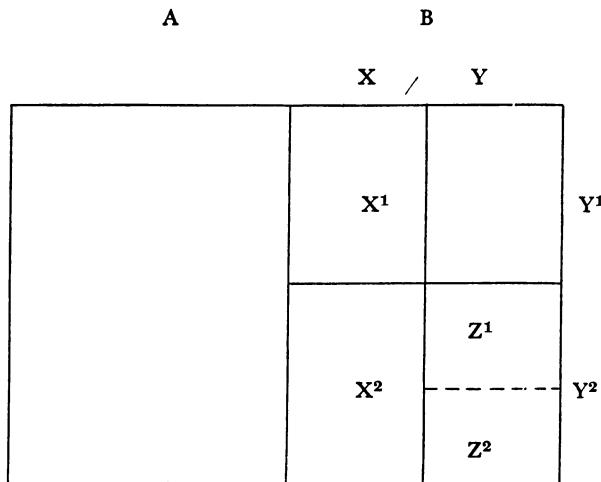

FIGURE 12: EVANS-PRITCHARD'S DIAGRAM SHOWING THE STRUCTURE OF A NUER TRIBE (1940c, p. 282)

Thus, on a structural plane, there is always contradiction in the definition of a political group, for a man is a member of it in virtue of his non-membership of other groups of the same type which he stands outside of, and he is likewise not a member of the same community in virtue of his membership of a segment of it which stands in opposition to its other segments. Hence a man counts as a member of a political group in one situation and not as a member in another situation . . . A tribal segment is a political group in relation to other segments of the same kind, and they jointly form a tribe only in relation to other Nuer tribes and to adjacent foreign tribes which form part of their political system, and without these relations very little meaning can be attached to the concepts of 'tribe' and 'tribal segment' (Evans-Pritchard; 1940c, pp. 281-282).

This analysis has been generally accepted as valid also for segmentary lineage systems. It implies that in these systems a smaller segment is not in a relation of subordination to a larger segment including it. Rather, smaller segments merge into a larger one in the context of a relationship of contraposition between this larger segment and yet another segment. Hence we should not speak about administrative relationships between segments, although there may exist administrative relationships between, for instance, a lineage headman or a council of lineage elders on the one hand and the other lineage members on the other hand. Since the genealogical charter of a segmentary lineage system does not itself imply the existence of administrative relations between lineages forming part of this system, it is incorrect to say that such systems are characterised by an extensive overlap of administrative and political functions. Rather, a lineage system consists of a series of groups who may emerge as competing political groups in contraposition to equivalent groups, for instance during a quarrel. These groups together might be called an administrative group, for instance during the implementation of the settlement of this quarrel.

Smith's definition of government as 'the management, direction and control of the public affairs of a given group or unit' (Smith; 1960, p. 15) does not specify either the nature of the public affairs (unlike for example Schapera's 1956 definition) or the means by which policy decisions come to be accepted (unlike for example Radcliffe-Brown's 1940 definition). The criteria by which Smith distinguishes government from other social processes are the specific governmental features of the process, namely decision making by contraposed groups or persons, and decision implementation by superimposed groups or persons.

In his 1959 review of recent publications in political anthropology, Easton appreciates Smith's efforts to find an 'antecedent and articulate theoretical orientation' to direct his analyses. He further considers that Smith's approach rightly avoids seeing 'the control over the use of

force' as 'the central political phenomenon' (Easton; 1959, pp. 224-225). However, he does not accept Smith's theory in its entirety. His first objection concerns the fact that Smith has only postulated the existence of an administrative hierarchy among lineages at the higher levels of segmentation and has not demonstrated that this is actually the case. This objection seems to fit in with my argument that it is not correct to infer the existence of authority relationships between lineages merely from the place of the founding ancestors of these lineages on the genealogical charter. Secondly, Easton considers Smith's subdivision of the governmental process into politics and administration to be not 'erroneous, but . . . too general to be of much use' (1959, p. 227). Instead he proposes a fivefold subdivision into: 1. the formulation of demands; 2. legislation; 3. administration; 4. adjudication; 5. the marshalling of support or solidarity (1959, p. 227). Easton does not adopt Smith's use of the term government. He uses the term 'political system' with which term he wants 'to identify the most inclusive set of political actions in a social system'. An act is 'political, as against economic, religious, or kin-type, for example, when it is more or less directly related to the formulation and execution of binding or authoritative decisions for a special system' (1959, p. 226). On the basis of this description it would seem that Easton's conception of 'political system' is very close to Smith's conception of 'government'. With regard to the study of Wanggulam government I would like to retain both Smith's terminology and his subdivision of the governmental process. The more refined subdivision as proposed by Easton does not fit the Wanggulam situation. Most of the governmental activities I described could not be classified into one of Easton's categories, unless the categories were stretched considerably. Once having opted for Smith's categorisation I feel I should also adopt his terminology, since I think that it may be confusing to include within 'political system' both politics and administration (compare Ganguly; 1963, p. 1155).

I have tried to account for the specific features of government among the Wanggulam by describing it in terms of four principles. In the course of the discussion it appeared that either the principle of competitive leadership, or the principle of partnership may qualify a Wanggulam as a leader. With the former the status of leader is achieved, with the latter it is ascribed. Ascribed statuses 'are assigned to individuals without reference to their innate differences or abilities' (Linton; 1936,

p. 115). Among the Wanggulam, however, this does not rule out political struggle.

During wedding ceremonies, in which leadership is ascribed, I noticed many people giving their unasked-for advice. The same happened, but to a smaller extent, during the cremation ceremonies (see p. 128 and p. 129).

Likewise I was told that the proclaimer of the pigfeast might be put under pressure to postpone or advance his proclamations (see p. 119).

On the other hand people assert that with the proclamations on the field of battle, made by the closest relative of a killed man, political struggles are absent (see p. 129). Yet considering the struggles which occur in the other situations in which leadership is ascribed I think this assertion might be untrue. In all these cases, it seems, there is political pressure, that is to say people try to influence the content of the decision to be taken, but they do not try to challenge the leader's authority.

With competitive leadership, statuses of power and authority are achieved, that is to say they 'are not assigned to individuals from birth but are left open to be filled through competition and individual effort' (Linton; 1936, p. 115). During the discussion of competitive leadership I argued that Wanggulam have continually to reassert their eminence; they have to keep on showing their verbal skill and their capacities as fighters and war leaders, lest they lose their prominent position. The political struggle implies therefore a struggle for authority. A big man owes his position to the fact that he is accepted as the most able man to determine the content of the decisions to be taken. If it appears that he has overlooked some factor which another man is able to point out, or, more generally, if it appears that the big man has not succeeded in persuading the other men that his own proposals indicate the best course of action, the big man's position of authority is diminished. By showing their capacities in planning raids and in bringing plans to the fore, smaller men may enhance their own position and may achieve leadership. But these struggles are not challenges to the authority of big men in general. They serve to bring the best qualified man into a position of authority.

I regret that no meeting in preparation for raids and battles took place during my stay. The proceedings might have shown more clearly how Wanggulam come to a decision and how individual men try to influence the content of the decision. Wanggulam asserted that big men were the only men to speak and that the other men complied

with their plans, but I was also told that during the actual fight the men who were fighting spread over a large area so that the big men could not exert much control over their actions. However, in several cases it appeared that after a big man had called an end to the battle, fighting stopped.

I would explain the many raids waged by small groups of men or by a single man as efforts both to gain prestige and to get retaliation. I had expected there would be other expressions of political struggle between big men. In particular I thought that in the case material there would be many instances of violence due to rivalry between big men, so that, for example, one would ask his wife or sister to work *mum* against one or more other big men in the same parish in order to advance his own position. Yet my data do not contain a single instance of such a request. Women working *mum* were always said to have been induced by more tangible, be it slight, reasons like a killing or a theft. I am not sure how to account for the lack of reports about violence between the big men belonging to the same parish; it might be that such violence was kept silent. Peacefulness between co-parishioners is often referred to as an asset and, since I got most of my information about fights and quarrels from men, they might have been inclined to attribute lack of peace within the parish not to competition between men but to injurious intentions of women. Moreover, *mum* is regarded as a typically female weapon, whereas men fight with weapons like bows and arrows. I suspect therefore, that, if a man had been known to have asked his wife or another woman to work *mum* against his rivals, this would have been a serious blow to his prestige. Because a Wanggulam may attain leadership in the context of either competitive leadership or of partnership, the question arises whether conflict may exist between the role expectations associated with these two principles. Further conflicts may obtain with the role expectations associated with autonomy or reciprocity.

Fallers has analysed conflicts between role expectations in his study of Soga government (Fallers, n.d.). Among the Soga, government is based upon a lineage organisation and upon a monarchical state. Fallers shows that conflicts between the expectations attributed to statuses in the two types of organisation may put the holders of office into a difficult position and hence lead to strain and instability. Strain is expressed in inter-personal and intra-personal conflicts; instability in the inability of institutions to operate (Fallers; p. 227).

For the New Guinea Highlands an example has been analysed by

Read (1959), who reports that the superior position of big men among the Gahuku-Gama is felt to clash with the supposed equality of adult men, so that there is no complementarity of expectations associated with the roles of 'big men' and of 'common men'. Among the Wanggulam I did not find any indication that the existence of big men was loathed. People said it was good that there were big men. They said that otherwise they would suffer defeat in war, while the leadership of big men brought victory. A few men said they disliked the possibility that one of their close relatives might be killed in retaliation for one of the people killed by a big man.

It was also asserted that the closest relative of a man killed on the battlefield would not be denied the right to decide upon prolonging or terminating the fight. People granted that fighters might comply only grudgingly, especially when they were wounded and had not yet taken revenge. It was said also that big men would not contest this right and this seems to be affirmed by Wurirrange's behaviour in Case 8 (p. 95). Although he was a big man, he reversed his decision not to fight when the closest relative of the killed man expressed his disapproval. The same absence of oppressive dominance by big men is seen in Case 22 (p. 163). Here my suggestion that Kondaga's status as a big man had induced him to put pressure on Lembiagop and his classificatory brothers was denied by my informants.

Finally, the wedding ceremonies I witnessed were all organised and led by the men who had reared the bride and the groom, and all death ceremonies by the closest relative of the deceased, although some of these men were quite small.

Although most Wanggulam can trace kin relationships to most other Wanggulam, kinship does not pervade their relationships. The range of effective kinship is narrow. I think that people do not derive more than a general feeling of relatedness from being each other's kin or affine, whereas the specific nature of a relationship is moulded by factors like residence, reciprocal services, and relative prestige position. I doubt also if kin ties matter greatly in influencing the plans of the big men. For example, Wandin led the Wanggulam when they revenged themselves upon the Tukobak. The biggest man of the Tukobak was Jikwanak who was the husband of the full (or maybe the close classificatory) sister of Wandin's father.

Kinship seems to pervade the relationship between full brothers. In the ideology of kinship they are subordinate to their elder brothers. We can compare their position with the position of the looked-down-upon

*eiloman* towards his 'false elder brother'. The subordinate position of the younger brother clashes with the notion of autonomy and gives him less chance to gain prestige (see p. 48). Wanggulam say that quarrels between full brothers are likely to be fierce and it seems significant that full brothers often do not live together (see table 3, p. 20).

In other situations minor strains may develop. A man dislikes the fact that, without giving notice, a kinsman may harvest a small part of the crop, e.g. a pandanus fruit, and thus may upset the plan the owner had for its use. He dislikes having many visitors around when he is roasting a stock of bananas or another delicacy, so that he has to share them out. Once, when it became known that a young man had returned from the Swart Valley with a large slab of salt, his FBD exclaimed immediately: 'Has he? I will go to see him. My elder brother'. She implied: 'I will ask him for a piece. He cannot refuse me'. She did go and returned with what she said was a very small piece of salt. In these last two instances the owners concerned may have been more resentful than otherwise because reciprocation was doubtful.

In the analysis of Soga government Fallers argues that:

It might be thought possible for both kinship and non-kinship roles to be prominent in the same social system so long as the contexts in which they operate be kept separate (Fallers; n.d., p. 15).

He illustrates this by reference to modern Western societies where kinship roles are dominant within the nuclear family but not outside it, so that outside the nuclear family roles can be assigned on non-kinship bases (Fallers; n.d., pp. 15 ff.). This argument should be qualified to make it applicable to Wanggulam. Here, kinship may be dominant outside the nuclear family, for example with the relationship with a real or close classificatory MB, or with close parallel or cross-cousins. It appears also that outsiders, including big men, recognise the importance of relationships between close kin and do not challenge their authority after a killing on the battlefield and during wedding and cremation ceremonies. Yet it would seem that the situations in which this is so are few and well defined and hence here the several principles can coexist.

In other respects they go against one another. In Chapter 8 (pp. 158 ff.) I argued that the beliefs in *mum* may be related to the fact that women do not have the same possibilities to compete for leadership as men have, and that this conflicts with their autonomy. *Mum* opens, prolongs, and reopens many conflicts and quarrels and thus brings

about strain and instability. As far as instability is concerned, *mum* may reopen a conflict even after *jowam* has been taken thus making the transfer of compensation ineffective in bringing the conflict to an end. Furthermore, strain and instability result from the competition for leadership, bringing about frequent disproportionate counter-actions (see p. 166).

In both cases we might argue that the principle of competitive leadership is not invalidated but rather reaffirmed. In the above explanation I argued that women would have liked to compete for leadership but that they are unable to do so through fighting with weapons like bows and arrows. In the latter case the desire to show oneself a good fighter, and thus a potential big man, overrides notions of reciprocity.

To what units do public affairs pertain? The boundaries of the political community are explicitly defined by the partnership principle and it appears that the majority of the people live among their agnates and on their traditional section territory. Although competitive leadership does not explicitly provide a formula by means of which to express the boundaries of the community, it does not necessarily follow that the size of the parishes is determined solely by the partnership principle. The parish is the stage on which the individuals act and the environment in which they can become prominent. It would seem that — in order to enjoy his prestige — a big man needs a group of admirers, his co-parishioners, whether devoted and/or sympathetic, or jealous and/or antipathetic, in daily contact with whom he can experience his superior qualities, besides having a group of enemies, members of other parishes, by whom he may be admired but with whom he is not on speaking terms.

The same duality was present in affairs pertaining to smaller units: the oil pandanus feast was held not only by 'Penggu' but also by 'Wandin'. The owners of the earth ovens did not only act as members of their section, but also as followers of Wandin.

In his discussion of lineage systems M. G. Smith argues that:

In the case of lineage systems, redefinition of the ideology of unilineal descent and lineage occurs in terms of accretions amalgamations, segmentation within the lineage, and fission as well as by the conceptualization of local groups in lineage terms. The lineage principle which forms the ideological basis of governmental organization permits many deviations from genealogical descent as well as correspondences with it, without thereby being invalidated in any way, or its dominance challenged (Smith; 1956, p. 64).

The situation among the Wanggulam seems to differ from that analysed by Smith, not only because the partnership principle is based on marriage and residence, and because the dogma of descent is only weakly held, but also because the other principle, competitive leadership, which underlies governmental organisation finds explicit institutionalised expression. Prominence of men is defined not in lineage terms, but on the basis of capacities as a fighter, a speaker and a leader. The principle of competitive leadership entails that the men, in their competition for prestige, try to influence the activities of the group. In Wanggulam the individual big men are political units. Administrative units are big men with their followers. The sections and their sub-groups have only a limited role to play in politics and administration and hence segmentation is not clearcut and does not follow the same lines. This analysis is based on Smith's proposition: 'The problem of lineage development, its form and formation, is therefore a problem of the governmental significance of lineage structures in any society'. (1956, p. 64).

Next we must consider what activities are regarded as public, and hence are the legitimate concern of the governmental organisation, and what are regarded as private and the proper concern of only those persons considered to be directly involved. If the public domain is wide and if the governmental organisation is segmentary along genealogical lines, it may well be true to say with Fortes (1953, p. 26) that 'the individual has no legal or political status except as a member of a lineage'. But for the Wanggulam this is not true, for here the public domain is comparatively narrow and in a large number of situations, in conformity with what I have called the principle of autonomy, each individual may decide what course of action he may follow, without being subjected to the authority of somebody else.

The question of segmentation brings us back to Easton's 1959 paper. Herein he proposes a typology of governments according to a 'three-dimensional scale of differentiation'. The dimensions are: 1. differentiation of 'political' from other social roles; 2. differentiation of one 'political' role from another; 3. differentiation in the degree of specialisation of 'political' roles (Easton; pp. 240-242). The dimensions of this scale will tend to be interrelated: low degree of specificity going together with little differentiation in the other dimensions. Among the Wanggulam there is some differentiation of political and social roles and also differentiation within 'political' roles, while there are also specifi-

cally 'political' roles. Easton does not provide a yardstick to measure differentiation and I suspect, firstly, that the construction of such a yardstick will prove very difficult and, secondly, that measurement will be nothing more than approximation. I am inclined to place Wanggulam at the low end of the continuum together with many other New Guinea Highlands societies, but I find it impossible to rank them relative to one other. But merely finding an appropriate pigeon hole for any kind of government is not the only use of the typology. Easton considers it helpful in 'understanding how different types of systems operate' (1959, p. 243). Firstly he holds that, where differentiation is low, recruitment of the socio-'political' roles will be largely ascribed. Among the Wanggulam and among other New Guinea Highlands peoples the role of the big men seems to be largely achieved. But since Easton does not specify the degree of differentiation to be correlated with ascription of 'political' roles, I have no means of ascertaining whether or not Wanggulam government fits his hypothesis. Secondly Easton holds that at the low end of the continuum decisions need not be supported by the use of legitimate force. This would seem to accord with the Wanggulam situation. Thirdly at the low end of the continuum high-level decisions will tend to be episodic. This also fits in with Wanggulam government. But it should be noted that small scale gatherings, like work and harvest parties, are numerous and reflect the same principles as the large gatherings do. Each of these parties is noticed by a substantial part of the parish. Fourthly and lastly, Easton holds that at the low end of the continuum there will be a high rate of segmentation. Here Easton uses 'segmentation' to refer to a process of subdivision and not to a state of subdivision (see U. P. Mayer in Barnes; 1954, p. 57, footnote). Again, I think, it is difficult to measure the rate of segmentation and to weigh the several types of segmentation which may take place. For example, in the case of the Tallensi, should we differentiate between the splitting of a minimal lineage and of a maximal lineage? And if so, how should we weigh the difference? (compare Barnes; 1954, p. 57). Can we regard increasing centralisation of government in the form of transfer of governmental responsibilities from provinces or municipalities to the state as an inverted form of segmentation, and how should we weigh this? Here is another difficulty involved: how should we weigh segmentation concerning only one of the governmental activities, for example splits in political parties? And how should we calculate a rate of segmentation when such a process occurs simultaneously with centralisation? What factors should be con-

sidered to account for the rate of segmentation among the Wanggulam? There is the possibility of both internal and external segmentation of the sections, further the possibility of the segmentation of the sections, further the possibility of the segmentation of a section pair, so that two independent section pairs come into being. Finally it seems to me we can speak of segmentation when the balance of power among the men changes, for example when the biggest among them dies or a young man ascends to power. Further there is external segmentation when men (with their families) leave. In the latter case we should also consider that the association of people with a parish may have an indeterminate character, making another difficulty in weighing this form of segmentation. I doubt therefore whether an exact calculus of 'the rate of segmentation' is at all possible.

Finally, I would like to repeat that autonomy among the Wanggulam is not absolute (see p. 71). Wanggulam seem to think it is up to people themselves whether they will join public events like work parties, wedding ceremonies, raids and so on. People are not forced to join, but do so voluntarily. In such a situation autonomy is restricted to the extent to which people are induced to take part in governing; to compete for power and to accept positions of super- and subordination. The stronger the arguments inducing people to do so, the more restricted their autonomy.

Just as common men are not forced to join public events, so big men and men acting as leaders on account of a kin relationship are not forced to take up leadership. This conflicts with Smith's 1960 argument that 'The administrative officer authorized to do certain things is required to discharge these duties, and can be legally punished for failure to do so'. Among the Wanggulam the only sanction for refraining from taking up leadership is a loss of status. According to Smith's formulations big men among the Wanggulam are merely the 'politically dominant' individuals 'neither committed . . . to take any specific actions . . .', 'nor punishable for refusal to take such action' (1960, p. 20). This argument seems to me to be unacceptable, since it implies that there are no administrative officers among the Wanggulam and hence that there is no government. But this is not so: there are public affairs and hence there must be government since 'government is the management, direction, and control of the public affairs of a given social group or unit' (Smith; 1960, p. 15).

In the discussion of Wanggulam government it was demonstrated that government in Wanggulam, as I have defined it, is concerned with

warfare and with internal cooperation, but has little to do with the maintenance of peace and order. It appeared also that intra-parish violence is a quite common occurrence. Hence a further problem should be discussed: why do the Wanggulam continue to live together as one parish? To this I now turn.

The study of social cohesion was given a new impetus by the analysis of stateless societies. Put in Gluckman's terms:

the anthropologist working in stateless societies has to seek for the fusion which is the other aspect of fission — does the anthropologist in studying a state not miss fission which is the other aspect of fusion, and therefore the character of the fusion itself which may exist outside of, in conflict with, the administrative framework? (Gluckman; 1947, in 1963, p. 52).

Gluckman seems to consider this enquiry the object of the study of government, or of 'political organisation', as he calls it. His conception of government differs thus notably from that of Smith. In a broadcast talk, entitled 'Political Institutions of Primitive Society', Gluckman describes his topic as follows:

In some . . . African states, as distinct from the smaller communities, we find political institutions more akin to our own. There are established governmental officers and councils with executive, judicial, and legislative powers . . . But a study of how the 'more primitive' societies, those without governmental institutions, live in political unity, under peace and order, opens new fields of interest (Gluckman; 1954, p. 66).

With the term 'order' Gluckman seems to refer both to the absence of violence and to the occurrence of a system of social relationships. In Chapter 3 of his book 'Politics, Law and Ritual in Tribal Societies', which chapter is called 'Stateless Societies and the Maintenance of Order', he writes for example:

It is essential to grasp this principle [one of three principles of 'political organisation' to be discussed below] if we are to understand how social groups maintain themselves. More particularly we require it to interpret how rules of self-help and vengeance operated without constantly disturbing social life (Gluckman; 1965, p. 111).

It is with the maintenance of order in the sense of the maintenance of a system of social relations that I am here particularly concerned.

In his 1965 book mentioned above Gluckman formulates three 'principles of political organization' 'of great social importance' (Gluckman; 1965, pp. 90-91). I will refer to these principles as 'elements' to avoid confusion with the principles on which I base my analysis of Wanggulam government. For reasons of expediency I will discuss these elements in reverse order.

The third element concerns the embodiment of the common interests of the members of a political community in mystical symbols. As far as I know such symbols are absent among the Wanggulam. They may contrast in this respect with other Dani, notably Dani living in the Grand Baliem Valley.

The second element concerns the fact that people or groups of people 'though theoretically exercising a delegated authority, in practice develop . . . an autonomous power of their own, as all subordinates tend to do' (Gluckman; 1965, p. 90). By way of example Gluckman refers to Hoebel and Llewellyn's analysis of the role of the Soldiers' Societies among the Cheyenne Indians. Among the Wanggulam such developments did not occur during the period from about 1940 to 1960, the year that the religious movement started. During the movement the pupils of the missionaries gained a great deal of power, exceeding the power delegated them by the missionaries. After I terminated my field work in August 1962 and left Wanggulam, they may have acquired more permanent positions of power and authority, as has happened in other parts of New Guinea in the course of comparable movements. Apart from the pupils, no one in Wanggulam has had authority delegated to him.

The importance of the first principle — the existence of social ties crossing group allegiances — in keeping tension within bounds and preventing large scale violence, was observed by Colson during her field work among the Plateau Tonga. She reported:

When a man seeks to act in terms of his obligations to one set of relationships, he is faced by the counterclaims upon him of other groups with which he must also interact. This entanglement of claims leads to attempts to seek an equitable settlement in the interests of peace, the public peace which enables the groups to perform their obligations to one another and a Tonga to live as a full member of his society. (Colson; 1953, p. 210).

The effectiveness of the division of loyalties in preserving order is doubted by Thoden van Velzen and Van Wetering (1960). They hold that the division of loyalties is not really crucial, since 'one tie outweighs the other . . . The loyalty resulting from shared interests outweighs the other loyalties' (Thoden van Velzen and Van Wetering; 1960, p. 185). But the conflicting loyalties theory seems to imply that the division of loyalties is to some extent paralleled by conflicts of interests (compare Gluckman; 1955, pp. 17-18 and p. 24). Moreover the criticism seems to take it that only the interests directly associated with the divided loyalties are at stake, whereas Colson says: 'the entanglement of claims

leads to attempts to seek an equitable settlement in the interests of peace'. This points to a conflict of interests, one of the interests being the maintenance of peace.

Colson's argument is concerned with the considerations of the individuals involved in the quarrel. It implies that they balance several courses of action and choose the one by which their interests are best served. In the case she presents she analyses the troubled situation brought about by a killing at a beer party. She demonstrates how third parties with interests in both the group of the victim and of the killer try to prevent fighting and effect a settlement. Colson quotes an earlier writer on the Tonga and comments:

Despite this observer's emphasis on disintegration and anarchy, the Tonga had their own methods of settling disputes and preventing general disorder and even he comments that murders were occasional rather than frequent and that compensation was sometimes paid (Colson; 1953, p. 200).

Hence not only the retaliatory fighting after killings was kept within bounds but also the killings themselves, so that the weighing of the advantages of different courses of action does not only influence the third parties (as it did in the case Colson observed) but may also curb the injurious intentions of those who otherwise would have been murderers. Such a dilemma — 'I had rather do this, but I had better do that' — imposed upon the individual members of the society, is also implied by Nadel's 1953 analysis of self-regulation. Nadel sees self-regulation operative in societies with a small degree of 'separation of social roles', that is to say in those societies in which, for example, every man is both a family head, a farmer and a possible candidate for priesthood. Failure in one of these activities involves failure in the others. Thus the man wanting to become a priest cannot neglect his task as a farmer, lest thereby he forfeits his chances of becoming a priest. Nadel's theory also points to a conflict of interests: it may be in a man's immediate interests if he gives minimal attention to his garden, namely in so far as it reduces his workload, but it is not in his long term interests, since it may harm his position in other contexts. The focuses of the two theories are different, the former focuses on limiting and preventing injurious behaviour like thefts, killings and fights; the latter focuses on neglect of one's duties as a family member, a gardener, a warrior and so on.

The formulation of the conflicting loyalties theory has been made possible by the intensive study of 'cases', of series of events in the social process. Gluckman (1961) has pointed out that such studies have led to a new handling of ethnographic data: whereas formerly case material

was used as 'apt illustration' of structural principles, more recently such principles are used as one of the factors accounting for the actions of the persons appearing in any of the cases. Moreover whereas formerly cases were studied as isolated incidents, they are now analysed as series of events within the more embracing series of events making up social life. Gluckman calls this new method of handling ethnographic data the 'extended-case' method (Gluckman; 1961, p. 13).

Van Velsen refers to 'situational analysis' (Van Velsen; 1964, pp. xxiii-xxiv). Gluckman describes as follows the analytical method used by Turner in his study of the Ndembu:

He first gives us a systematic outline of the principles on which Ndembu villages are constructed and measures their relative importance with . . . numerical data. Then he takes the history of one village through twenty years to show how these abstract principles have operated through that history, within the chance occurrences of illness, death and other misfortunes, of good luck, of individual temperament and ambition and finally of . . . British overlordship (1957, p. xi).

Analyses based on extended cases like those of Van Velsen and of Turner, are concerned with the careers of individual people and the development taking place within kin and territorial groups. The focus is on long term goals, especially the attainment of the headmanship of villages and the establishment and endurance of large villages. In these analyses people are shown to 'use' social relationships, to turn them to their advantage, and to manipulate. Colson (1953) was concerned with a short term goal, the restoration of peace. She analyses one troubled instant in the careers of these people whom she reports as initially feeling anxiety at the possible disruption of their social life; but who also — once a settlement seems to have been reached — start manoeuvring (Colson; 1953, p. 209).

Van Velsen states that he is concerned with 'politics' which he defines as:

those activities which, on the part of an individual or individuals, result in leadership within and control over particular groups, or which, in the case of competition between groups, bring leadership and control of one group over others (Van Velsen; 1964, p. 3).

and later as 'skilful manipulation of personal relationships within an elastic framework of formal values' (1964, p. 6). Van Velsen tries to account for the source of order (1964, pp. 1-2) and he gives two reasons, firstly,

departures from formal norms . . . are not in open defiance of these norms, which would invalidate or weaken them, but are rather in terms of generally accepted values and thus appear to support these values.

In the case of 'norms relating to headmanship' this means that 'rivals for power and office all operate within the same normative system and ultimately strengthen it' (Van Velsen; 1964, p. 314). The second source of cohesion Van Velsen indicates is the 'positive effects' of the many '(often petty) disputes' among the Nyasaland Tonga in which they 'reaffirm and re-analyse the relationships within the village or larger unit, which in the aggregate provide the foundation for their feelings of identity' (1964, p. 315).

It would seem there is a discrepancy between Van Velsen's earlier definition of politics as 'manipulation . . . within an elastic framework of formal values' and the former of the two sources of cohesion he proposes. A more appropriate definition of politics among the Nyasaland Tonga might be: 'skilful manipulation of personal relationships, in terms of elastic formal norms, but in the framework of common values'.

Van Velsen's formulation of politics, especially in the formulation of his first definition (1964, p. 3), comes close to Smith's 'political action' (compare also Barnes' 1959 comments on Frankenberg's use of 'politics'. Unlike both Van Velsen and Frankenberg, Barnes refers explicitly to Smith). In his 1956 paper Smith set forth his theory on an abstract level without showing the way in which political and administrative action as 'the management, direction and control of the public affairs of a given group or unit' is actually carried on. Van Velsen deals with politics as embodied in the acts of individuals. He shows how, in order to advance their own position, people use their personal relationships and their memberships of groups. This implies that he is concerned not merely with 'the public affairs of a given group or unit', but also with the affairs of the smaller sub-groups and their members. With his conclusions he remains within the analytical framework set out by Gluckman and his collaborators. But, with the conflicting loyalties theory they have not indicated the source of cohesion, the forces which bind people together in their community. The theory has provided a deeper insight into social morphology, and has pointed out specific expressions of cohesion. In order to account for the fact that there is cohesion at all, Gluckman refers to the need for public safety (1954a, p. 68 and 1954b, p. 134).

My lack of data on personal motivation prevents me from giving a coherent picture of Wanggulam manoeuvring. I might explain Wogogi's behaviour in Case 19 (p. 154) in terms of a conflict of interests. When he wanted to fight Ngwembanik after the latter had killed Enggang-gok, he was asked not to fight, with an appeal to parish loyalty. It may

be that Wogogi realised that he might alienate Enggangkok's kinsmen from him by not trying to revenge Enggangkok's death, but he preferred to avoid getting on bad terms with other co-parishioners. Wogogi did not tell me, though, whether this was the crucial reason or whether other reasons were involved.

Similarly, we might explain Awiambaga's behaviour in the case 'Wogogi's dog' (see p. 92) as a result of a conflict of interests. Awiambaga himself resided with Wonggimburu's father and close by Wonggimburu, while his full elder brother lived with Wogogi's younger brother and close by Wogogi. But again I do not know for sure whether Awiambaga felt that his relationship with his elder brother might be threatened if it would come to a fight. His behaviour was explained only by reference to the maintenance of peace.

The deficiency of my data shows up most in respect to the careers of big men. It might be that they manoeuvred their co-parishioners into fights, or conversely kept them from fighting, in order to advance their own positions. It is possible for instance that Wandin had this specific motive in mind when he led the Wanggulam on the raids against Jikwanak and his co-parishioners (see Case 2, p. 79). I also suspect that people have specific reasons for trying to arrange a marriage according to the ideal pattern, or alternatively not to the ideal pattern.

Because of this lack of information on personal motivation I focused more on structure than on politics and more on general interests and general targets than on specific interests and specific targets people may have had in mind. My cases are more 'apt illustrations' than 'situational analyses'.

What are the interests which bring the Wanggulam into cooperation? During wars and their preparations people are enticed to co-operate because only by joining a group can a man prove himself a good war-leader, and can consequently attain the highest prestige. When a man abstains from fighting he is regarded as a coward and his prestige dwindles, so that it is advantageous to join, even for a mediocre fighter.

Participation in harvest feasts gives the individual an opportunity to show his industry. By joining the feast, by adding his harvest to those of others and thus by cooperating in the organisation of the feast, an average man can show a much larger group of people that he is a good gardener and he can keep up a much larger range of transactions than he could hope to do by organising a feast of his own.

Participation in a working party also brings one's industry to the fore. Supporting others implies obliging them to reciprocate the support, so

that by joining the parties organised by others one secures support for the parties one organises oneself.

By marrying his daughter to the son of one of his co-parishioners a man ensures that the ceremonies will bring him in the focus of interest within the circle of his co-parishioners, with whom he can continue his exchange relationships. This attraction exists in addition to the appeal the marriage has as an expression of the partnership principle. For unmarried men, or men who want to marry a second or a third wife, conformity to the ideals of being a good fighter and a hard worker has other rewards, as cowardly and lazy men are said to be not in high repute with women and to have less chance of marrying. Yet another advantage of intra-parish marriages is that it entails the vicinity of cognatic kin, especially of ZS's and KZS's.

It should be noted that these advantages induce men to cooperate, but that they do not compel formation on the lines of the partnership principle. It seems that its appeal rests upon its working as an exchange mechanism, in the way formulated by Lévi-Strauss.

Apart from the advantages of joint action implied in the competitive leadership system, people cooperate in order to avoid serious quarrels in the parish because these would create too dangerous a situation: one could easily be ambushed on a trip to one's gardens or one's pandanus holdings. A number of men told me: 'You do not kill co-parishioners. That is much too close by', thus lending support to Gluckman's association of social cohesion with the need for public safety. I never heard people advance moral arguments condemning physical violence within the parish, except when Komak reproached Jiwaru for fighting Arigunik. On that occasion he stressed the close relationship between Jiwaru and Arigunik by stating repeatedly: 'One does not shoot at one's ZS' (see p. 100). The situation created by a great many intra-parish quarrels is the more dangerous because of the possibility of *mum*. Women are supposed not only to vindicate their own cause, but also those of relatives like their husbands and close agnates (see Case 19, p. 156 and Case 15, p. 141). People seem to think that women can work *mum* only on those persons they have actually in view. Accordingly there is more risk involved in angering a female member of the parish than in angering a foreign woman, since it is relatively easy to keep out of sight of a foreign woman, but very difficult not to be seen by a woman of the same parish. Because of former fights and killings a number of people, especially men, never leave Wanggulam lest a foreign woman would notice and kill them.

Unlike the Tonga the Wanggulam are a people where not only petty disputes but also serious fights and quarrels do occur. It might be asked therefore whether the Wanggulam consider the maintenance of peace to be one of their interests. With interparish relationships men do not seek to avoid fighting: they need fights to become — as Colson puts it — ‘full members of their society’ (1953, p. 210). Joining a fight in Mbogoga does not result from hostile feelings for the whole or even a part of the opposing party. The fights are an expression of enmity between a few men or two groups, the principal fighters, joined by secondary fighters. If a killing should occur during the fights, public peace would be further disturbed, for example if a secondary fighter was killed, so that a new conflict would arise with a new set of principal fighters. This could easily lead to new outbursts of fighting. The Wanggulam realise this possibility and they say that big men urge the termination of the fight ‘lest other people are killed’. This shows that, although people value fights as a means of gaining prestige, they do not desire unbridled fighting, not even between parishes. We might compare this with an analysis of fights on Choiseul (Scheffler; 1964), who also notes a differentiation of motives for joining fights and adds that the participation of fighters who are only slightly interested may promote termination of the fighting. ‘Once involved they cannot simply ‘quit’, but they can help to find an honorable way out for all concerned’ (Scheffler; 1964, p. 797). This may be the same among the Wanggulam, though I did not hear it explicitly affirmed.

Scheffler suggests further that on Choiseul ‘peace’ is valued positively because of the insecurity of wars and because gift exchange can take place only in time of peace. The former argument applies well to the Wanggulam situation, but the latter only to a limited extent. Gift exchange would seem to be more important among the Choiseusele Scheffler studied than among the Wanggulam. A financial reason why the Wanggulam stop a fight may be that *jowam* are very large, for it is a great burden and it leads to a great loss of valuables to have to compensate two or more killings.

Within parishes also, much fighting goes on. I noted that motives for the fights may be slight but that I doubt if the fighters always intend to kill when starting the fight. With *mum*, it appears that, although people suspect women of working *mum* on the slightest provocation, most women proven to have worked *mum* were believed to have done so for serious reasons (see p. 53).

Quarrels and animosities do not easily divide the parish or its sub-

divisions into opposing factions. Wanggulam are usually united by ties of kinship or affinity. They regard their co-parishioners as living 'close by', and with many co-parishioners they maintain exchange relationships through contributions to wedding and other payments, support in fights against outside enemies and participation in working parties. Third parties to quarrels between co-parishioners mostly do not break off their relationships with either of the parties but remain on speaking terms with both. Thus discord concerns only the relationships between the parties themselves and does not contaminate other relationships. Notwithstanding the discord between Komak and Jiwaru, the latter's wives (suspected of having worked *mum*) kept visiting the former's hamlet while Komak's wife, his children, and Nginarek, his MZS, who was living in the same hamlet as Komak, kept visiting Jiwaru. Wanggulam said that this would not have gone on, if either Jiwaru or Arigunik had been killed. The killing would have led to a fight, resembling the fight which occurred in the case Luki versus Ambenggonok (see p. 125). The rifts which such fights indicate are also not as deep as one may think. People may use the occurrence of these fights to demonstrate their displeasure with their fellows, as Katlengga and Kelele did when they joined the opposing party. Such behaviour is not regarded as high treason.

I should point out also that the rift between Jiwaru and Komak was not absolute. They spoke to each other after Komak had cursed Waugwe and after the latter had discovered that one of his stocks of bananas had been stolen and suspected that Arigunik had been the thief (see p. 102).

In a review of Turner's study of the Ndembu — in which book Turner emphasised the importance of 'conflicting loyalties' (Turner; 1957, pp. xxii-xxiii) — Stanner argues: 'If the Ndembu are governed by anything, then it is by their interests rather than, as Turner would have it, by their principles'. (Stanner; 1959, p. 215). This seems to assert a general discrepancy between principles and interests which, at least in the case of the Wanggulam, does not occur. The principles are clearly correlated with the things the Wanggulam value most highly: the renown of the warrior, communal undertakings like pigfeasts and working parties, their taking part and yet largely remaining their own masters. It is true however, that principles and interests do not accord completely.

In Chapter 8 I noted that retaliation is often excessive and then may result in a long series of troubles. Although the Wanggulam assert that

their relations with co-parishioners and their own parish's relationships with other parishes are based upon reciprocity, and that they attempt to restore a balance, in actuality reciprocity and balance are far to seek. Using Smith's conceptualisation we might say that the ideal policy of the Wanggulam is the maintenance of balance. By 'policy' Smith refers to a 'plan or course of action . . . adopted or proposed for adoption, by a government, ruler, individual, party, or other group' (Smith; 1960, p. 17). In actuality Wanggulam do not hold on to this policy when working *mum* or when trying to gain prestige on the field of battle. I think people are aware of the fact that insults and bickering may lead to brawls and more serious forms of fighting and that this underlies their assertion that one should keep the peace. When during ceremonies discord seemed to develop, I heard people often remark that one should not fight and abuse one another. Quarrelsome and outspoken people are disliked. In fact, Wanggulam often vent their grievances in very subtle ways only, and often not in public. This is especially noticeable during the distribution of payments. When the recipient waits a few moments before accepting the payment, it is clear that he is indicating that he is not really satisfied and wants more (compare the reactions of Komak and of Eleanggwe's daughter during the distribution of Waugwe's *uak*, p. 103). This contrasts with the situation among other New Guinea Highlands peoples: Kuma are prone 'to bicker in public about the smallest grievances' (Reay; 1959, p. 193). About the Chimbu, Brown reports: 'Most of the death ceremonies I witnessed were characterised by aggressive demands [for the death payment] by the kin of the deceased and attempts by the sub-clan [of the deceased] to settle with a small payment' (Brown; 1961, p. 3). The contrast is mainly outward, though, since Wanggulam also are often grieved and do brood about their grievances. It would seem that people are likely to try, be it subtly, to receive more from a payment than the donor had initially intended to give them.

It seems to me that the Wanggulam consider retaliation on the same scale as the initial offence to be legal or legitimate. (Compare Smith; 1960, p. 20; 'Legality connotes conformity to the law . . . , while legitimacy refers to a wider order of norms and principles and ultimately to the traditional moral system . . .'). Since it is not a separate sphere of activities, I find it impossible to distinguish clearly between legitimacy and legality in Wanggulam government). Yet Wanggulam do not draw the conclusion that excessive retaliation is illegal and illegitimate. Although people often stressed that they had to retaliate because of the

losses they had incurred, and they often related the number of losses they had inflicted to those they had incurred, they did not show any uneasiness about their disregard for balance and reciprocity. At the end of Chapter 8 I described some phenomena correlated with the lack of balance and reciprocity. They might result from conflicts of interests; peacefulness and personal safety conflicting with being a good warrior (as in the case of men) or with being inferior to men (as in the case of women). Ngunduarek gave an inkling of this conflict after I had asked him how people would deal with an excessively warlike co-parishioner, intent upon incessant raiding. He answered that such a man would be admonished not to go on in this way, since that would create enemies all around, but he added proudly: 'That is what we Wanggulam were like, we had enemies on all our borders'. The same ambiguity was shown in, firstly the admiration for big men and the efforts to gain prestige by fighting, and, secondly, the avowed dislike of the resulting unsafety (see p. 167 and compare also Scheffler; 1964, p. 798).

Nevertheless, the Wanggulam have continued to live as co-parishioners. After they had been defeated by Jikwanak and his co-parishioners, and had been chased from Mbogoga, they lived in several groups dispersed over several parts of the highlands for at least four years, and then re-assembled to resume parish life. There are indications that, during the period 1935-1960, other Mbogoga parishes have been scattered for comparable periods of time, but that they also re-assembled. The short duration of the period I can survey prevents me from saying whether some parishes were scattered, never to re-unite.

What other processes, next to intra-parish and inter-parish violence, might have jeopardised the continued existence of Wanggulam parish?

In his 1954 'Political Systems of Highland Burma', Leach demonstrates the inadequacy of studying Kachin social structure in terms of discrete 'societies' — 'any self-contained political unit' (1954, p. 5) exhibiting an unchanging social structure, with 'principles of organisation that unite the component parts of the system' (1954, p. 4) and a uniform culture; 'Culture provides the form, the 'dress' of the social situation' (1954, p. 16). Among the Highland Burmese studied by Leach these conditions did not obtain. As well as cultural differences there were structural differences, while the social organisation was unstable over time, due to adaptation and subsequent abandonment of the underlying structural principles. Leach distinguishes three ideal types of 'political' structures: Shan, *gumsa* and *gumlao*. In actuality

the different types of organisation are often mixed: a community may show both Shan, *gumlao* and *gumsa* features. Leach holds that changes in organisation occurring over time are causally interrelated (1954, p. 204).

Leach's views can be compared with those of Fallers concerning the Inter-Lacustrine Bantu state area:

Though at any one point in time the country might consist of a series of autonomous political units, the mechanisms for maintaining conformity with normative patterns often involved more than one such unit and often resulted in the creation of new units . . . Perhaps I should say that within this whole area [the whole of the Inter-Lacustrine Bantu state area], common political institutions were operative, but that over time various political units structured in terms of these institutions crystallised out at different periods (Fallers; n.d. pp. 247-248).

I do not dispose of the historical data which would allow me to demonstrate conclusively the presence or absence of changes such as hypothesised by Leach and Fallers.

Mbogoga would seem to have a uniform culture (in Leach's sense) and Wanggulam can be treated as a distinct social unit within Mbogoga. Its distinctiveness appears both in conceptualisation and in actual behaviour. Abstractly Wanggulam is a unit because it is centered on a section pair (see p. 112); in actual behaviour we can observe its unity in, for example, the intermarriage pattern, the degree to which co-parishioners contribute to wedding payments (see pp. 40 ff.), the amount of *jowam* taken between co-parishioners (see p. 153), the organisation of the pigfeasts (see pp. 119 ff.), and so on.

Other units within Mbogoga — the Wanggulam asserted — were based on the same principles as is their own. People could provide me with the names of the pairs with which these units were identified. They could name the big men of these units and parts of their war records. With several of these units they maintained exchange relationships. I have no indication whether autonomy was less important among them than it was among the Wanggulam.

But next to these units there were other small groups about which I could not collect much information. Close by Wanggulam there were two such groups. Neither had an ally. One was indicated by a *anembeno* name, the other had come into being after a few Karoba men had left Wanggulam and had settled on the south bank of the Mbogo opposite Wanggulam. I was told that this had happened because they had participated in a ceremony introduced by one of them after a stay in the 'Baliem area'. A number of people had died shortly

after the performance of the ceremony and there were suspicions that the women thought these events to be causally connected and wanted to take revenge on the participants. This group numbered four, and maybe one or two more, adult men. By 1960 most had returned, but the man who had introduced the ceremony had not. Before his flight he had been a big man. Information about his later status was vague. The other small group lived west of Wanggulam on the north bank of the Kurip. This group had come 'from the Swart Valley because of war'.

It would seem therefore that these were two cases of people who had fled, and not of people who had deliberately split off to form a separate group, preferring an even greater independence than life in a parish like Wanggulam could offer them. If this were the case we might compare it with the situation among the Kachin where a group may split off a *gumsa* state to form a *gumlao* community. I feel insufficiently informed to say whether a comparable split off did not occur at all among the Mbogoga Dani.

Leach's analysis raises also the question how long a section pair, and the parish of which it is the centre, remains in existence. Wanggulam did not show great interest in the distant past or the distant future of their parish. They do not have mythical or (pseudo)-historical accounts explaining the relationship between Penggu and Karoba sections. The genealogies I collected seem to indicate that the second ascending generations of the present adults formed a section pair. Wirz, who reports section pairs from the Swart Valley, visited the area in 1921-22. That the constituent parts of a parish may hang close together is indicated by the reunion of the Wanggulam after they had been chased from Mbogoga and had spent at least four years dispersed in several groups in different parts of the highlands.

I doubt also whether the Wanggulam distinguish individuals according to their political aspirations or administrative status in the way the Kachin do. The latter may say that so and so is 'becoming Shan' or 'becoming *gumlao*' (Leach; 1954, p. 286). It does seem that to different Wanggulam adults autonomy and competitive leadership carry different weight. It was said of Mbobigi that he was a 'solitary man', living on his own, not seeing a great deal of other people and working mostly on his own. There were several such men among the Wanggulam. Hence we might say that for these men autonomy had more significance than for the other men. But it should be noted that even Mbobigi was not living completely on his own, that he planned to build together with

his ZH, Ngabengga, that he attended working parties and that he every now and then organised one. Also there were no indications that he resented the then form of Wanggulam organisation and wanted to see it replaced by an organisation characterised by a still greater diffusion of power and authority.

Gluckman considers the changes as described by Leach and Fallers to be 'repetitive . . . without producing . . . any fundamental change of pattern' (1963, p. 37). In his 1964 introduction to the second impression of his Kachin study Leach has not contested that view.

Initially Gluckman had thought that cross-cutting ties not only kept quarrels within bounds and led to their settlement:

Custom directs and controls the quarrels through conflicts of allegiance, so that despite rebellion, the same social system is re-established over wider areas of communal life and through longer periods of time (Gluckman; 1955, p. 47).

Yet one cannot account for the continued existence of a system of groups by referring only to the successful efforts made by the members of the groups to maintain peace in single instances. Such an account would ignore, firstly, the latent functions that peace-keeping activities might have and, secondly, all other processes which may be at work. More recently Gluckman has written that

Social systems are not nearly as integrated as organic systems, and the processes working within them are not as cyclical and repetitive as are those in organic systems (Gluckman; 1963, p. 38). In reality, too, each process may work over a relative limited period of time: then external events, or the cumulative working of varied and often opposed processes, may alter the basic pattern of the system (1963, p. 39).

Again, the historical data are lacking which might lend support to Gluckman's hypothesis. But we should keep in mind that the contemporary data indicate that the Wanggulam are very receptive to alien elements. They incorporated new ceremonies (see p. 51), while the teachings of the missionaries influenced them deeply. Like other Highlands peoples they were keenly interested in trying out new crops so that corn, introduced by missionaries at the Wissel Lakes in 1938 or later, had already reached Wanggulam before the establishment of the mission station at Mbogondini. By 1960 this new crop had become a choice food which was often distributed at working parties.

Judging from these contemporary data we should therefore not altogether reject the possibility of changes in 'the basic pattern' even if the missions and the Dutch administration had not penetrated into the Highlands.

## BIBLIOGRAPHY

- Barnes, J. A.  
1954 *Politics in a Changing Society*. Cape Town, Oxford University Press.  
1959 'Politics without Parties', *Man*, Vol. 59, pp. 13-15.  
1962 'African Models in the New Guinea Highlands', *Man*, Vol. 62, pp. 5-9.  
1967 'Genealogies', in *The Craft of Anthropology*, A. L. Epstein, Editor, pp. 101-127, London, Tavistock.
- Bernardi, B.  
1952 'The Age-system of the Nilo-Hamitic Peoples', *Africa*, Vol. 13, pp. 316-332.
- Bromley, M.  
1960 'A Preliminary Report on Law among the Grand Valley Dani of Netherlands New Guinea', *Nieuw-Guinea Studiën*, Vol. 4, pp. 235-259.  
1962 'Leadership in Grand Valley Dani Society', *Working Papers in Dani Ethnology*, No. 1, pp. 1-7.
- Brookfield, H. C.  
1962 'Local Study and Comparative Method: An Example from Central New Guinea', *Annals of the Association of American Geographers*, Vol. 52, pp. 242-254.
- Brown, P.  
1961 'Chimbu Death Payments', *The Journal of the Royal Anthropological Institute*, Vol. 91, Part 1, pp. 77-96.  
1963 'From Anarchy to Satrapy', *American Anthropologist*, Vol. 65, pp. 1-15.
- Bulmer, R. N. H.  
1960 'Political Aspects of the Moka Ceremonial Exchange System among the Kyaka People of the Western Highlands of New Guinea', *Oceania*, Vol. 31, pp. 1-13.  
1961 *Leadership and Social Structure among the Kyaka People of the Western Highlands District of New Guinea*. Unpublished Ph. D. thesis, A.N.U.
- Colson, E.  
1953 'Social Control and Vengeance in Plateau Tonga Society', *Africa*, Vol. 23, pp. 199-212.
- Colson, E. and Gluckman, M. (Editors)  
1951 *Seven Tribes of British Central Africa*, London, Oxford University Press.
- Conklin, H. C.  
1963 *The Study of Shifting Cultivation*. Washington D.C.

- Easton, D.  
 1959 'Political Anthropology', In *Biennial Review of Anthropology* 1959, B. J. Siegel, editor, pp. 210-262, Stanford, Stanford University Press.
- Ellenberger, J. D.  
 1962 'On leadership amongst the Damals (Uhundunis) North of the Carstensch Mountain Range', *Working Papers in Dani Ethnology*, No. 1, pp. 10-15.
- Evans-Pritchard, E. E.  
 1940a *The Nuer*, Oxford, Clarendon Press.  
 1940b 'The Political Structure of the Nandi-speaking Peoples of Kenya', *Africa*, Vol. 13, pp. 250-267.  
 1940c 'The Political System of the Nuer', In *African Political Systems*, M. Fortes and E. E. Evans-Pritchard, editors, London, Oxford University Press.
- Fallers, L. A.  
 n.d. *Bantu Bureaucracy*. Cambridge, Heffer and Sons.
- Fortes, M.  
 1945 *The Dynamics of Clanship among the Tallensi*. London, Oxford University Press.  
 1953 'The Structure of Unilineal Descent Groups', *American Anthropologist*, Vol. 55, pp. 17-41.
- Fortes, M. and Evans-Pritchard, E. E.  
 1940 'Introduction' In *African Political Systems*, M. Fortes and E. E. Evans-Pritchard, editors, pp. 1-23, London, Oxford University Press.
- Ganguly, P. G.  
 1963 'Political Systems: An Anthropological Approach', *The Economic Weekly of Bombay*, Vol. 15, pp. 1151-1160, 1327-1338.
- Glasse, R. M.  
 1959 'Revenge and Redress among the Huli', *Mankind*, Vol. 5, pp. 273-289.
- Gluckman, M.  
 1947 'An Advance in African Sociology', *African Studies*, Vol. 6, reprinted in *Order and Rebellion in Tribal Africa*, pp. 50-83, London, Cohen and West.  
 1954a 'Political Institutions', in *The Institutions of Primitive Society*, pp. 66-80; Oxford, Basil Blackwell.  
 1954b 'Rituals of Rebellion in South-East Africa', Manchester, reprinted in *Order and Rebellion in Tribal Africa*, pp. 110-136, London, Cohen and West.  
 1955 *Custom and Conflict in Africa*. Oxford, Basil Blackwell.  
 1957 'Foreword' to *Schism and Continuity in an African Society*, by V. W. Turner, pp. ix-xiii, Manchester, Manchester University Press.  
 1961 'Ethnographic Data in British Social Anthropology', *The Sociological Review*, New Series, Vol. 9, pp. 5-17.  
 1963 'Introduction' to *Order and Rebellion in Tribal Africa*, pp. 1-49, London, Cohen and West.  
 1965 *Politics, Law and Ritual in Tribal Society*. Oxford, Blackwell.

- Heider, K. G.  
 1962 'Leadership', *Working Papers in Dani Ethnology*, No. 1, pp. 16-18.  
 1962a Personal Communication.
- Held, G. J.  
 1951 *De Papoea Cultuurimprovisator*, 's-Gravenhage, van Hoeve.
- Hitt, R. T.  
 1962 *Cannibal Valley*. New York, Harper and Row.
- Hoebel, E. A.  
 1954 *The Law of Primitive Man*. Cambridge (Mass.), Harvard University Press.
- Hogbin, H. I. and Wedgwood, C. H.  
 1953 'Local Grouping in Melanesia', *Oceania*, Vol. 23, pp. 241-276, and Vol. 24, pp. 58-76.
- Larson, G. F.  
 1962 'The Fetish Burning Movement among the Western Ndani Papuans', *Working Papers in Dani Ethnology*, No. 1, pp. 54-58.  
 1962a 'Warfare and Feuding in the Ilaga Valley', *Working Papers in Dani Ethnology*, No. 1, pp. 32-39.
- Leach, E. R.  
 1954 *Political Systems of Highland Burma*. London, Bell and Sons.  
 1964 'Introductory Note to the 1964 Reprint' of *Political Systems of Highland Burma*, pp. ix-xv, London, Bell and Sons.
- Le Roux, C. C. F. M.  
 1948-1950 *De Bergpapoea's van Nieuw-Guinea en hun woongebied*. 3 vols. Leiden, E. J. Brill.
- Lévi-Strauss, C.  
 1949 *Les Structures élémentaires de la parenté*. Paris, Presses universitaires de France.
- Linton, R.  
 1936 *The Study of Man*. New York, Appleton Century.
- Lorentz, H. A.  
 1913 *Zwarte mensen, witte bergen*. Leiden, E. J. Brill.
- Malinowski, B.  
 1934 'Introduction' to *Law and order in Polynesia*, H. I. Hogbin, pp. xvii-lxii, London.
- Matthiessen, P.  
 1962 *Under the Mountain Wall*. New York, The Viking Press.
- Meggitt, M. J.  
 1957 'Enga Political Organisation', *Mankind*, Vol. 5, pp. 133-137.  
 1958 'The Enga of the New Guinea Highlands: Some Preliminary Observations', *Oceania*, Vol. 28, pp. 253-330.  
 1965 *The Lineage system of the Mae Enga*. Oliver and Boyd, Edinburgh.

- Middleton, J. and Tait, D.  
 1958 'Introduction' to *Tribes without Rulers*, J. Middleton and D. Tait, editors, pp. 1-31, London, Routledge and Kegan Paul.
- Nadel, S. F.  
 1953 'Social Control and Self-Regulation', *Social Forces*, Vol. 31, pp. 265-273.
- O'Brien, D. A.  
 1963 Personal Communication.
- O'Brien, D. A. and Ploeg, A.  
 1964 'Acculturation Movements among the Western Dani', *American Anthropologist*, Vol. 66, ii, pp. 281-292.
- Parsons, Talcott  
 1960 *Structure and Process in Modern Societies*. The Free Press of Glencoe, Illinois.
- Peters, H. L.  
 1965 *Enkele hoofdstukken uit het sociaal-religieuze leven van een Dani-groep*. Venlo, Dagblad voor Noord-Limburg N.V.
- Pospisil, L.  
 1958 *Kapauku Papuans and their Law*. Yale University Publications in Anthropology, no. 54, New Haven.  
 1963 *Kapauku Papuan Economy*. Yale University Publications in Anthropology no. 67, New Haven.
- Pouwer, J.  
 1961 'New Guinea as a Field of Ethnological Study', *Bijdragen tot de taal-, land- en volkenkunde*. Vol. 117, pp. 1-25.  
 1962 *Het individu in samenleving en cultuur*. Groningen, Wolters.
- Radcliffe-Brown, A. R.  
 1935 'Patrilineal and Matrilineal Succession', *Iowa Law Review*, Vol. 20, reprinted in *Structure and Function in Primitive Society*, pp. 32-48, London, Cohen and West, 1952.  
 1940 'Preface' to *African Political Systems*, M. Fortes and E. E. Evans-Pritchard, editors, pp. xi-xxiii, London, Oxford University Press.
- Read, K. E.  
 1954 'Cultures of the Central Highlands of New Guinea', *Southwestern Journal of Anthropology*, Vol. 10, pp. 1-43.  
 1955 'Morality and the Concept of the Person among the Gahuku-Gama', *Oceania*, Vol. 25, pp. 233-282.  
 1959 'Leadership and Consensus in a New Guinea Society', *American Anthropologist*, Vol. 61, pp. 425-436.
- Reay, M. O.  
 1959 *The Kuma*. Melbourne, Melbourne University Press.
- Sahlins, M. D.  
 1963 'Poor Man, Big-Man, Chief: Political Types in Melanesia and Polynesia', *Comparative Studies in Society and History*, Vol. 5, pp. 285-300.

- Salisbury, R. F.  
 1956 'Asymmetrical Marriage Systems', *American Anthropologist*, Vol. 58, pp. 639-655.  
 1962 *From Stone to Steel*. Melbourne, Melbourne University Press.  
 1964a 'Despotism and Australian Administration in the New Guinea Highlands', *American Anthropologist*, Vol. 66, Special Publication New Guinea: The Central Highlands, pp. 225-240.  
 1964b 'New Guinea Highland Models and Descent Theory' *Man*, Vol. 64, pp. 168-171.
- Schapera, I.  
 1956 *Government and Politics in Tribal Societies*. London, Watts and Co.
- Scheffler, H. W.  
 1964 'The Genesis and Repression of Conflict', *American Anthropologist*, Vol. 66, pp. 789-804.
- Smith, M. G.  
 1956 'On Segmentary Lineage Systems', *The Journal of the Royal Anthropological Institute*, Vol. 86, Part 2, pp. 39-79.  
 1960 *Government in Zazzau 1800-1950*. London, Oxford University Press.  
 1966 'A Structural Approach to Comparative Politics', in *Varieties of Political Theory*, D. Easton, editor, pp. 113-128, Prentice-Hall Englewood Cliffs, New Jersey.
- Stanner, W. E. H.  
 1959 Continuity and Schism in an African Tribe, A Review, *Oceania*, Vol. 29, pp. 208-217.
- Strathern, A.  
 1966 'Despots and Directors in the New Guinea Highlands', *Man*, N.S. Vol. 1, pp. 356-367.
- Thoden Van Velzen, H. U. E. and Van Wetering, W.  
 1960 'Residence, Power Groups and Intra-Societal Agression', *International Archives of Ethnography*, Vol. 49, pp. 169-200.
- Turner, V. W.  
 1957 *Schism and Continuity in an African Society*. Manchester, Manchester University Press.
- Van Velsen, J.  
 1964 *The Politics of Kinship*. Manchester, Manchester University Press.
- Wirz, P.  
 1924 'Anthropologische und ethnologische Ergebnisse der Zentral Neu-Guinea Expedition 1921-1922', *Nova Guinea*, Vol. 16, pp. 1-149.

## INDEX

The names of those Wanggulam who are mentioned only once in the book, are not entered in the index

- Abena, 2-3, 20, 151.  
abduction, 92, 125.  
achieved leadership, see Leadership.  
administration, 66-7, 169, 172-4, 179, 182.  
affiliation, 170.  
*aga polenggwe* (retaliatory magic), 56, 154, 156.  
agnatic, 12-3, 16-8, 22, 131.  
agricultural techniques, 11.  
alliance (see also Penggu), 32, 113-5.  
ally, 17, 48, 115, 119, 127, 193.  
Ambenggonok, 125, 144-6.  
Amianongga, 146, 149-50.  
*amulok kunik* (fight magic), 47, 76, 79, 81, 89, 109, 137, 162.  
Anarak, 104, 149-50.  
ancestors, 6, 16-8, 48, 115.  
ancestral spirits (*anggena*), 46-51, 76, 81, 115, 119.  
*anembeno* ('agnatic' descent group), 13-7, 61, 115-7.  
'apt illustration' method, 185.  
Archbold Lake area, 20, 79, 141.  
Arigunik,  
    and compensation for his KZS, 55-6, 153.  
    versus Jiwaru, 95, 105, 139-40, 143, 188, 190.  
    on Penggu pandanus feast, 123.  
    genealogy, 96, app.  
arrow carving, 130.  
ascribed leadership, see Leadership.  
associates, 18-9, 21-2, 123.  
authority, 67, 69, 84-5, 105-6, 108, 174-5, 178, 183.  
Autlen, 122, 146, app.  
autonomy, 66, 68-73,  
    on Penggu pandanus feast, 89, 125.  
    and private affairs, 110, 138.  
    on pig feast, 121.  
    and compensation, 152-3.  
    of women, 158.  
    not absolute, 177, 181.  
    different importance for Wanggulam men, 194-5.  
avoidance, 137, 139-40.  
*awe* (see also Compensation payment), 143-4, 147.  
Awiambaga, 92, 146, 187.  
Bachelor, 37.  
    confirmed bachelor, 109, 120.  
Baliem, Baliem Valley,  
    contact with people living in Baliem Valley, 1-2, 87, 194.  
    pig feast, 72, 141.  
    big man, 75-8, 141.  
    social organisation, 114-6, 183.  
Barama River Caribs, 138.  
Barnes, J. A., 16, 114, 121, 170, 180, 186.  
barrenness, 56, 103-4.  
battle (see also Fight), 161-4.  
    introduction to the field of battle, 72.  
    role of big men during battles, 84, 105, 115, 174-5.  
    mentioned in cases, 125, 134-5, 137, 155, 163.  
    tactics, 162-3.  
    ending or adjourning, 176, 184.  
    attire, 162.  
    show aspect, 163.  
Bernardi, B., 170.  
Bible stories, 60, 65, 101.  
big man,  
    qualifications, 13, 75-8.  
    and religious movement, 48, 64-5.  
    career, 80-1, 174, 187.  
    affairs in which they exert power and authority, 84-92, 127, 129.  
    as a mediator, 95, 105-6, 157.  
    different aspects of their status, 105-8, 111, 192.  
    and oppressive dominance, 106, 161, 176.

- on Penggu pandanus feast, 124-5.
- rivalry between big men, 175.
- and admirers, 178.
- no obligation to act, 181.
- big woman, 159.
- Bismarck archipelago, 115.
- blood money (see also *Jowam*), 118.
- boundaries between gardens, 70, 139.
- bravery, 47, 76.
- bride price, 27-45, 83, 104-5, 110, 128-9.
- Bromley M., 1, 10, 75-8, 114-6, 118.
- Brookfield H. C., 11.
- Brown P., 36, 75-8, 191.
- Bulmer, R. N. H., 74-7, 81-2, 85.
- Bushman, 168.
  
- Carstenz Range, 114.
- cassowary, 11.
- ceremonies following killings, 119.
- Cheyenne soldiers' societies, 183.
- Chimbu, 75-8, 106, 191.
- chivalry, 160.
- Choiseul, 189-90.
- Christianity, 4-6, 52, 58-65, 80, 85, 103, 165.
- circulation of valuables, 37-45, 77.
- Colson E., 183-5, 189.
- Comanche, 71.
- compensation (see also *Awe*, *Jowam*, *Ka*), 10, 24, 37, 50, 143-53.
  - in trouble cases, 56-7, 92, 101, 125, 165.
  - assemblage and distribution, 78, 107-9.
  - conflicts over compensation, 135-6.
  - efficacy, 166, 178.
- competitive leadership, see Leadership.
- confederacy, 116.
- confirmed bachelor, see Bachelor.
- conflict, chapter 8 (133-67).
  - numerical data, 133.
  - motives, 135-6.
  - conflict of principles, 177-8.
  - conflicting loyalties, 183-5, 187, 195.
  - conflict between interests and principles, 190-1.
  - conflict of interests, 191, 2.
- Conklin H. C., 10.
- corporate affinity, 113-4.
- corporation, 67.
- court, 94.
- cowards, 82, 109, 187.
- cowrie shell and cowrie shell band, *passim*.
  - function, 10.
  - circulation, 27-45.
- cremation, 24, 98, 107, 128-9, 174.
- cremation payment, 10, 34-7, 44, 95, 98, 129.
- crime, 138-9.
- cross-cousin marriage, 113.
  
- Daily routine, 11.
- death payment (see also Cremation payment), 191.
- delegated authority, 183.
- descent, 16, 130, 170, 179.
- despotism, see Oppressive dominance.
- diet, 4, 10-1.
- dog, 11, 91-2.
- Dutch administration, 3-4, 10, 58, 65-7, 79, 83, 105, 195.
  
- Eaburak, 126, 145.
- East New Guinea, 8, 85.
- Eastern Dani (see also Baliem Valley), 75, 78.
- Easton D., 168-9, 172-3, 179-80.
- eiloman* (ward), 19, 71, 78, 80, 110, 149, 177.
- Eleanggwe, 96, 102-3, 191.
- Ellenberger J. D., 76, 78, 114.
- Enga, 34, 74-7, 85.
- Enggangkok, 160-1, 186.
- Enggawarek, 154-7, 165.
- Engginduk, 79, 163.
- equality, 106, 165.
- Erimawe, 82-4, 91, 108, 120, 161.
- Eskimo, 138.
- European way of life, 5, 61-5.
- Europeans, 3-5, 39, 58, 63, 65, 93, 107.
- Evans-Pritchard E. E., 169-72.
- exchange, 77, 85, 113, 117, 121, 131.
- exogamy, 12, 113, 116-7.
- extended case method, 185.
  
- Faction, 77-8, 101, 140, 190.
- Fallers L. A., 175-7, 193, 196.
- feasting ground, 120.
- feeble-minded man, 19, 110-1, 166.
- fight (see also Battle, Parish, Raid, Sudden outburst of fighting).
  - attitudes towards fighting, 6, 58, 165, 188.
  - support of ancestral spirits, 47-9.
  - preceding meetings, 84-5, 106, 175.
  - frequent occurrence, 107, 133, 191.
  - leadership during fights, 107.
  - quantitative data, 112, 135.

- cooperation of *anembeno* members during fights, 116.  
 motives, 133, 164.  
 principal and secondary fighters, 163, 189.  
 show aspect, 163-4.  
 terminology, 166.  
 financier, 78.  
 foreigners, 13-5, 144-6.  
 Fortes M., 169-70, 180.  
 Frankenberg R., 186.
- Gahuku-Gama, 75-6, 138.  
 gangs, 94, 160.  
 Ganguly P. G., 173.  
 gathering of food, 10.  
 genealogical charter, 48, 117, 171-2.  
 genealogy, 14, 16, 48.  
 Glasse R. M., 75, 94.  
 Gluckman M., 182-3, 184-6, 189, 195-6.  
 Grand Valley, see Baliem.
- Hablifoeri, 1-2.  
 hamlet,  
   groundplan, 8-9.  
   garden, 10.  
   number and size, 22.  
 harvest feast (see also Penggu pandanus feast and Swart Valley, nut pandanus feast), 13, 25-6, 84-90, 107-9, 111, 121, 127, 180, 187.  
 Heider K. G., 76, 117.  
 Held G. J., 114.  
 Hitt R. T., 58.  
 Hoebel E. A., 67, 138, 183.  
 Hogbin H. I., 2, 12.  
 houses,  
   men's, 9, 22.  
   women's, 9, 22-3.  
   construction, 9.  
 Horne F. C., 6.  
 Huli, 75, 94.  
 hunting, 10, 72.
- Ikwenggorok, 82-4, 92, 100-1, 105, 108, 122, 142, 152, app.  
 Ilaga Valley, 5, 114-5, 117.  
 immaterial damage, 147.  
 Inter-Lacustrine Bantu, 193.  
 industry, 76, 109, 187-8.  
 initiation, 72.  
 insecurity of Wanggulam society, 64, 167.  
 interpreter of dreams, 130.  
 intervention in fights, 68, 100-1, 105.
- Jambutitlek, 146, 155.  
*jao*, passim,  
   description and function, 10.  
   circulation, 27-45.  
   abandonment, 61-2, 65.  
*jeget nungganggen* (personality trait of big men-to-be), 80-1.  
 Jiganganugwe, 96, 99, 101, 155-6.  
 Jikwanak, 79, 133-4, 163, 176, 187, 192.  
 Jilobo, 148, 150-1.  
 Jiwaru,  
   on Penggu pandanus feast, 87, 89, 123.  
   versus Arigunik, 95-106, 139-40, 143, 165.  
   versus Komak, 100-2, 190-1.  
   genealogy, 96, app.  
*jowam* (blood money; see also Compensation payment), 144-53.  
   size, 144, 153, 189.  
   for Ambenggonok's killing, 144-7.  
   transfer, 148.  
   series of *jowam*, 149, 52.  
   efficacy, 152.  
   numbers transferred, 153, 193.  
   partners to *jowam*, 164.  
 Jowet, 96, 103, app.  
*jundurak* (obtuse), 109, 165.
- Ka* (type of compensation, see also Compensation payment), 143-4, 147.  
 Kachin, 192-5.  
 Kapauku, 76-8, 82, 94.  
 Karoba (see also Penggu),  
   composition, 13-6.  
   residence pattern, 19-21, 32.  
   throwing away of *jao*, 61.  
   Karoba big men, 81.  
   genealogies, 82, 126, 145-6, 149, 155.  
   on Penggu pandanus feast, 87, 122.  
   in cases of trouble, 92, 95, 117-9, 125-6, 139, 144-7, 149, 151, 154-7, 160-1.
- Karubaga, 86, 117.  
 Katlenga, 125-6, 145, 163, 190.  
 Kelele, 126, 145, 190.  
 kinship terminology, 13, 61.  
 Komak,  
   genealogy, 55, 96, 155, app.  
   and compensation for Perenatmendek's son, 56.  
   on Penggu pandanus feast, 88-90, 122-3.  
   and quarrels between Jiwaru and Arigunik, 95-105, 140, 165, 188, 190.  
   versus Jiwaru, 100-2, 190-1.

- Kondaga, 122, 134, 161, 176, app.  
 Kuma, 76, 81-2, 94, 191.  
 Kuranggen, 136, 147.  
 Kurelu, 141.  
 Kurip, 23, 79, 87, 91, 94, 139, 143, 163, 194.  
 Kwamok, 79, 145, 151.  
 Kweratlek, 96-104.  
 Kyaka, 74-6, 81-2.
- Larson G. F., 62, 114-5, 117.  
 Leach E. R., 192-5.  
 leadership (see also Big man),  
   competitive, chapter 6 (75-111), 125, 174-5, 178-9.  
   war leaders, 78.  
   wealthy leaders, 78.  
   during fights, 84-5.  
   during harvest feasts, 86-90, 109, 127.  
   open, 108, 129-30, 158-9.  
   rotating, 108.  
   during working parties, 108-9, 127.  
   during wedding ceremonies, 128-9, 176.  
   during cremation ceremonies, 129.  
   of specialists, 129.  
   during transfer of compensation, 148.  
   ascribed leadership, 173.  
   achieved leadership, 173-4.  
 legal norms, 138.  
 legality, 191.  
 legitimacy, 191.  
 Lembiagop, 93-6, 100-5, 161, 176.  
*lembo* (category of spirits; see also Spirit), 50-1, 53.  
 Lenggaroba, 122-3, 142-6, app.  
 Lenit, 57, 122, app.  
 Le Roux C. C. F. M., 1, 8, 117.  
 Lévi-Strauss C., 113, 188.  
 lineage, 17, 179.  
   structure 169-72.  
   ideology, 172, 178-9.  
 Linton R., 71-2, 173-4.  
 Llewellyn K., 183.  
 Luaga, 2, 18, 20, 52, 91.  
 Luki, 125-6, 141, 144-5, 147, 190.  
 Luobarak, 146, 154-7.
- Mabu,  
   composition, 13-5.  
   status in Wanggulam parish, 17, 112.  
   territory, 20-1.  
   throwing away of *jao*, 61.  
   big man, 81.  
   participation in parish affairs, 118, 137.  
   magic, 46, 53-8.  
 Malinowski B., 74.  
 Manggumbini, 96-8, 122-3, 140, app.  
 Matthiessen P., 72, 162.  
 Mayer U. P., 180.  
 Mbabuarek,  
   versus Wandin, 91, 94, 107.  
   versus Luki, 106, 141-3.  
   superior to his +B, 109.  
   his *eiloman*, 110.  
   Penggu pandanus feast, 122.  
   disappearance during daughter's wedding, 140.  
   move south of the Kurip, 141-3.  
   genealogy, 142, app.  
   versus Mbobigi, 143.  
   and Jilobo's death, 152.  
 Mbilumu, 92-4, 149-50.  
 Mbobigi,  
   genealogy, 82, 142, app.  
   and his S and ZS, 83-4.  
   on Penggu pandanus feast, 122.  
   residence, 143.  
   versus Mbabuarek, 143.  
   and Jilobo's death, 148, 150-2.  
   versus Tanarak, 164.  
   autonomy, 194-5.  
 Mbogo, 1, 3, 105, 139.  
 Mbowamb, 75-6, 106, 114.  
 Mbukmba, 92-4, 96, 102.  
 Mbula, 19.  
 Mbunarek, 126, 145, 163.  
 mediation (see also Big man), 94, 101, 105, 152.  
 Meggitt M. J., 34, 36, 74, 77.  
 Melanesia, 73-4, 77.  
 Middleton J., 170.  
 missionaries,  
   influence on Wanggulam behaviour, 3-6, 10, 101, 148, 195.  
   and religious movement, 58-64.  
   meetings and feasts, 69, 85, 94, 116, 118.  
   mission pupils, 5, 60-1, 64-5, 183.  
 moieties, 116-7.  
 Moka, 85.  
*monggat* (category of spirits, see also Spirit), 46, 50-1, 119.  
 moral judgment on behaviour, 139.  
 moves, 140-3.  
*mum* (sorcery worked by women), *pasim*,  
   methods, 52-3, 55, 156, 189.

- victims of, 53.  
 motives for, 53.  
 methods to identify who has committed sorcery, 54-5.  
 structural cause, 158.  
 threat to intra-parish peace, 159.  
 mystical symbols, 183.
- Nadel S. F., 184.  
 Nandi-speaking peoples, 170.  
 Nanembulukwe, 98, 103.  
 native evangelists (see Mission pupils).  
 Ndembu, 185, 190.  
 Ngabengga,  
   helping his B, 55-6.  
   residence, 82-3, 91, 99, 195.  
   relationship with stepson, 82-3.  
   genealogy, 95.  
   role in pig feast, 120.  
   non-participation in pandanus feast, 123.  
   recipient of *jowam* for Ambenggonok, 146.  
 Nganu, 2, 118, 152.  
 Ngerenggaligwe, 55, 98, 153.  
 Ngigamuli, 95, 105, 135, 140.  
 Nginarek, 55-6, 98, 122-3, 190, app.  
 Ngobak, 126, 145, 163.  
 Ngomengga, 123, 136, app.  
 Ngopare,  
   composition, 13-5.  
   associated with Wanggulam, 18, 112, 118.  
   territory, 20-1.  
   settling among Wanggulam, 79, 140, 153.  
   big man, 81.  
   participation in Penggu pandanus feast, 88-90, 123.  
   backing Arigunik against Jiwaru, 99.  
   versus Kondaga, 161.  
 Ngunugaro, 92, 149.  
 Ngwembanik,  
   versus Mbilumu, 93-4.  
   on Penggu pandanus feast, 122.  
   versus Amianongga, 149-50.  
   versus Enggangkok, 160-1, 186.  
   genealogy, app.  
 Nuer, 169-71.  
 Numfoor, 115.  
 nut pandanus feast, see Swart Valley.
- O'Brien D. A., 4, 38, 114-5, 117.  
 open leadership, see Leadership.
- oppressive dominance, 106, 161, 176.  
 oratory, 76.  
 order, 182.
- Panaga, 3, 93-4, 134, 140.  
 parish, 2, 7, 12, 14-5, 17, 60, 112, 179.  
   intra- and inter-parish marriages, 17, 112-113.  
   intra- and inter-parish fights and killings, 112, 188-9.  
   intra- and inter-parish exchange of economic services, 113.  
   public affairs, 118-121.  
   continued existence, 182-96.  
   factions, 190.  
 Parsons T., 67.  
 partnership, 68, chapter 7 (112-32), 173, 178-9, 188.  
 patrilineage, 16.  
 patri-lineage, 114.  
 Penggu,  
   composition, 13-6.  
   alliance with Karoba, 17, 112, 115, 119, 131, 164, 195.  
   association with Ngopare, 18.  
   residence pattern, 20-2.  
   pandanus feast, 21-2, 86-9, 122-5, 127.  
   big men, 81.  
   members in trouble cases, 92-3, 95-105, 118-9, 142-3, 150-2, 160-1, 164.  
   genealogies, 142, 149, app.  
   intra-Penggu fight, 150.  
 Perenatmendek, 54-6, 98, 153.  
 personal motivation, 187-8.  
 Peters H. L., 72, 75, 77, 114, 116, 141.  
 petty disputes, 186, 189.  
 physically unattractive man, 93, 109-10.  
 pig feast, 119-21, 193.  
   proclaimers, 119, 130, 174.  
 policy, 66, 84, 191.  
 political function, 172, 179.  
 'political organisation', 168.  
 political struggle, 174-5.  
 political units, 172-3, 179.  
 politics, 66-7, 173-5, 179, 185-8.  
 polygyny, 77.  
 Ponarit, 122, 142-3, 152, app.  
 Pospisil L., 76-8, 82, 94.  
 postulate, basic cultural, 67.  
 Pouwer J., 74, 113-4, 163.  
 power, 66-7, 69, 76-7, 84, 89, 92, 94, 105-7, 131.  
 prestige, 107-9, 121, 123, 127, 175, 187.

- private affairs, 69, 110, 179.  
 public affairs, 66-70, 138, 178-9, 181.  
*pulinggwe* (retaliatory magic), 56, 103-104, 154.
- Radcliffe-Brown A. R., 168-9, 172.  
 raid, 24, 79, 84, 94, 136, 159-61, 163-4, 175.  
 Read K. E., 8, 75-6, 138, 176.  
 Reay M. O., 19, 76, 81-2, 94, 191.  
 reciprocity, 66, 68, 73-4, 113, 179, 191-2.  
 reconciliation ceremonies, 119.  
 religious movement, 5, 8, 38, 58-65, 107.  
 representation, 107.  
 responsibility for killings, 119, 164-5.  
 rhetoric thumper, 76.  
 rights in *genetricem*, 35.  
 rights in *uxorem*, 35.  
*rite de passage*, 72.  
 role conflict, 175-7.  
 rotating leadership, see Leadership.
- Sahlins M. D., 77-8.  
 Salisbury R. F., 4, 76, 106, 113-4.  
 Schapera I., 169, 172.  
 Scheffler H. W., 189-90, 192.
- section,  
 definition, 12.  
 territory, 13, 17, 19-20.  
 sub-section, 14-20, 48.  
 sub-sub-section, 14-9.  
 main section, 17.  
 and rights over married women, 35-6.  
 section pairs, 112, 114, 193-4.  
 public affairs, 121-7.
- segmentary lineage system, 168-73.  
 segmentary principle, 170.  
 segmentation, 48, 67, 117, 179-81.  
 self-regulation, 185.  
 Sepik, 115.  
 settlements, chapter 8 (133-67).  
 shifting cultivation, 10.  
 Siane, 4, 76, 106.  
 situational analysis, 185, 187.  
 small man, 75, 109.  
 Smit S., 4.  
 Smith M. G., 66-7, 84, 168, 170-3, 178, 181, 186, 191.  
 snake and bird race, 62.  
 Soga, 175.  
 sovereignty, 71.  
 'specialist spirit', 50-2, 129.  
 spirit (see also *Lembo*, *Monggat*, 'Specialist spirit'), 6-7, 46, 49, 63, 115, 134, 160.  
 Stanner W. E. H., 190.  
 stateless society, 169-71, 182.  
 steel implement, 4, 6, 27-9, 31, 59, 64.  
 Strathern A., 75-6, 106, 114.  
 sub-section, see Section.  
 sub-sub-section, see Section.  
 sudden outburst of fighting, 161.  
 mentioned in trouble cases, 83, 91, 95, 100, 141, 150-1.  
 suicide, 98.  
 Swart Valley (see also Panaga),  
 contacts of Wanggulam with Swart Valley, 1-3, 20, 93, 100, 144, 154, 177, 194.  
 religious movement, 63.  
 nut pandanus feast, 86, 89, 121.  
 alliance, 114-5.  
 moieties, 117.
- Tait D., 170.  
 Tallensi, 180.  
 Tanarak, 122, 142, 151, 164, app.  
 Taukanet, 91, 94.  
 technology, 8-11.  
 theft, 135.  
 Thoden van Velzen H. U. E., 183.  
 Tikit, 122, 142, app.  
 Tilubagatlak, 54-6, 153.  
 Tiragop, 95, 105, 140.  
 Tonga,  
 Plateau Tonga, 184, 189.  
 Nyasaland Tonga, 186.  
 Tukobak, 2, 3, 79, 133, 136, 151, 161, 176.  
 Turner V. W., 185, 190.
- Uak*, 27-45, 56, 62, 71, 102-3, 128.  
 Uhunduni, 76, 78, 114.  
 Unevangelised Fields Mission, 3, 5, 6.
- Value-orientation, 68.  
 van Velsen J., 185-6.  
 van Wetering W., 183.  
 verbal skill, 13, 76.  
 vicinage, 17, 121.
- Wabit, 13-5, 54.  
 Wandamendek, 134, 146.  
 Wandin,  
 role at weapon burning, 60, 90.  
 biggest man among the Wanggulam, 75, 95.

- amount of power, 76.  
 career, 78-80, 187.  
 role during Penggu pandanus feast, 86-90, 122-3.  
 asks Ngopare to settle in Wanggulam, 90, 153.  
 versus Mbabuarek, 91, 94, 107.  
 role in the quarrels between Jiwaru and Arigunik, 99, 101-2, 105-6.  
 his *eiloman*, 110.  
 versus Mbobigi, 150-1.  
 helps Ngwembanik, 160-1.  
 kin relationship with Jikwanak, 177.  
 genealogy, app.  
 warfare (see also Fight), 2, 116, 188.  
 war leader, see Leadership.  
 (excessively) warlike man, 138, 163.  
 Waugwe, 96, 102-5, 190.  
 wealth, 77.  
 wealthy leader, see Leadership.  
 weapon burning, 59, 90.  
 wedding ceremony, 24, 27-37, 71, 107, 128-9, 158, 174, 177.  
 wedding payment (see also Bride price, *Uak*), 10, 27-45, 61-2, 73, 78, 109, 128.  
 Wedgwood C., 2, 12.  
 Wirz P., 10, 114-5, 117, 194.  
 Wissel Lakes, 195.  
 Wogogi, 134.  
   and his dog, 92, 94, 143, 147, 187.  
   helps Liokwe, 136.  
   genealogy, 146, 155.  
   versus Mbobigi, 151.  
   and the quarrels after Mbaganarek's death, 154-7.  
   threatens Ngwembanik, 161, 186-7.  
 Wonggimburu, 143, 147.  
 working party, 25-7, 71, 107-8, 111, 127, 187-8.  
 Wuram, 91-4, 99, 122-3, 146, app.  
 Wurirarange, 95, 105, 140.

APPENDIX

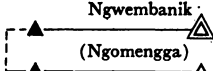
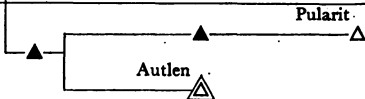
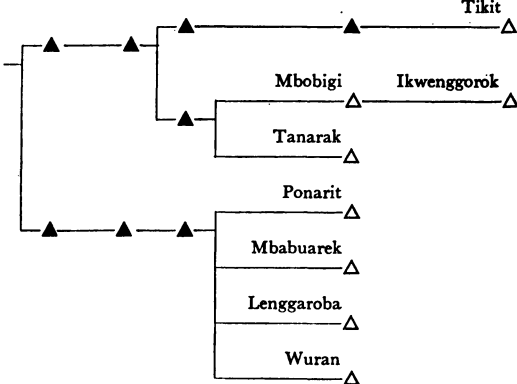
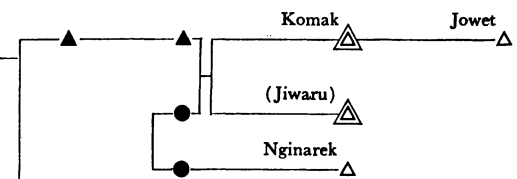
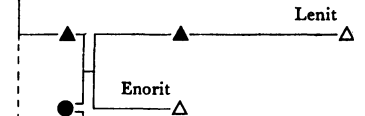
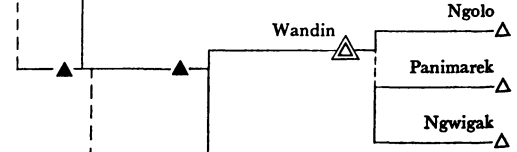
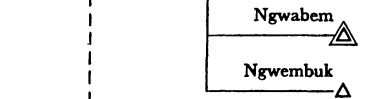
a	b	Ia	Ib	Ic	IIa	IIb	IIc	III
1	1	/	/	/	/	/	/	Pb 
2	10	+	+	-	+	+	-	
3	3	+	+	+	+	-	+.+.+.-	Pc 
4	4	- MZS	+	-	+	+	+	Pa 
5	9	+	+	-	+	+	-	
6	8	+	-	-	+	+	+	Pc 
7	5	+	-	-	+	-	+.+	Pa 





**MAPS**

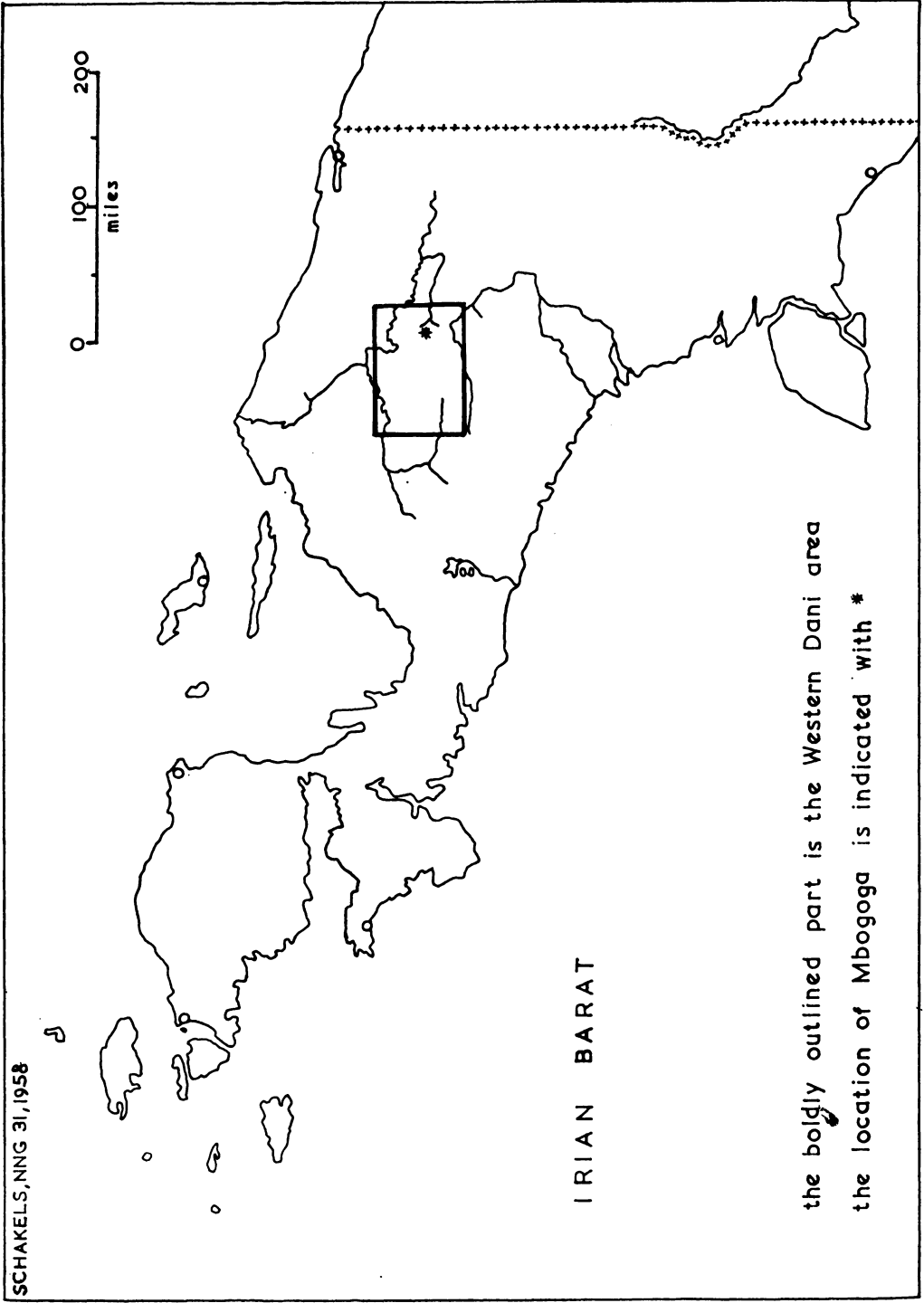

SCHAKELS, NNG 31, 1958

IRIAN BARAT

the boldly outlined part is the Western Dani area  
the location of Mbogoga is indicated with \*

MAP I

IRIAN BARAT

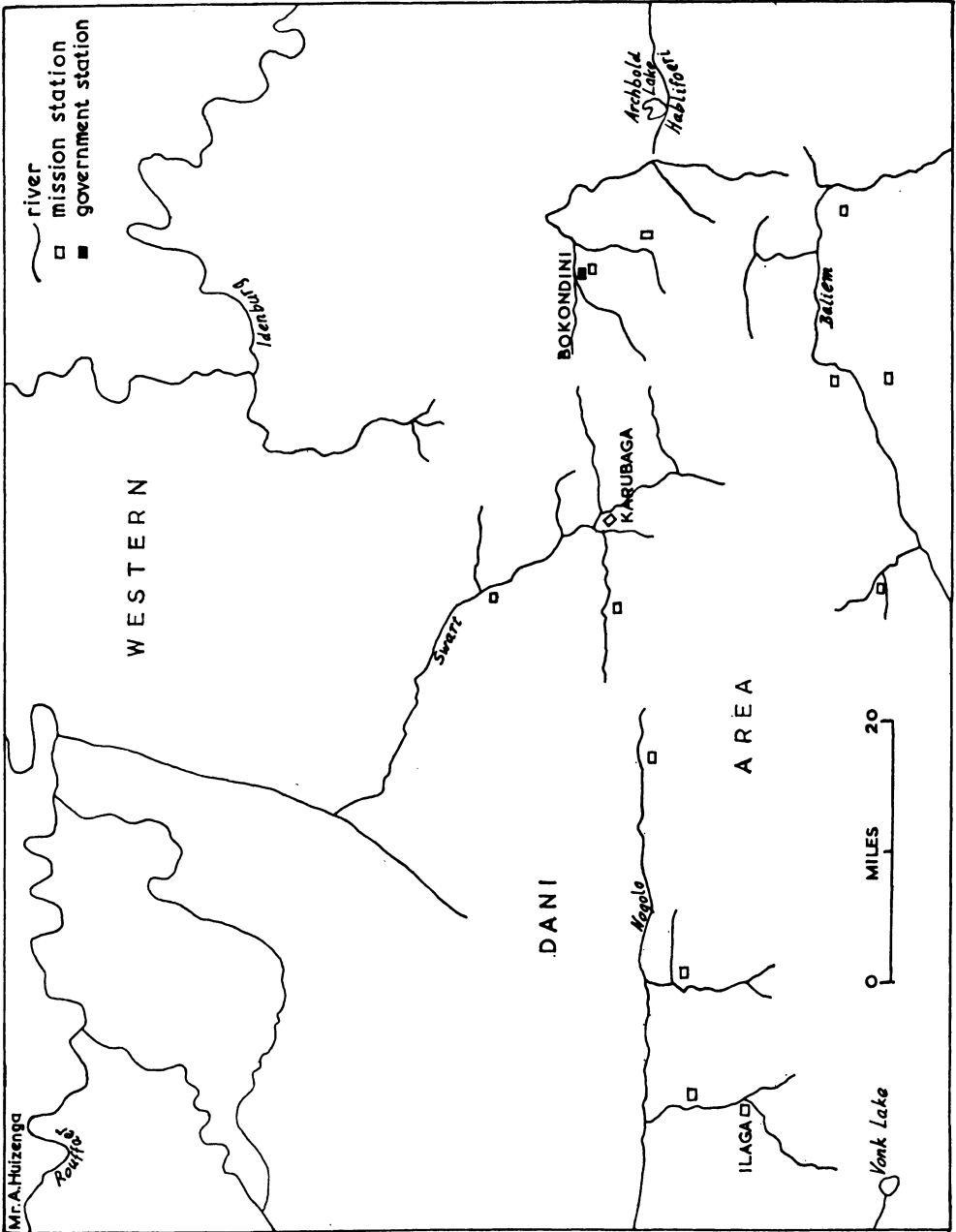

MAP II WESTERN DANI AREA

MAP III AND V WANGGULAM TERRITORY

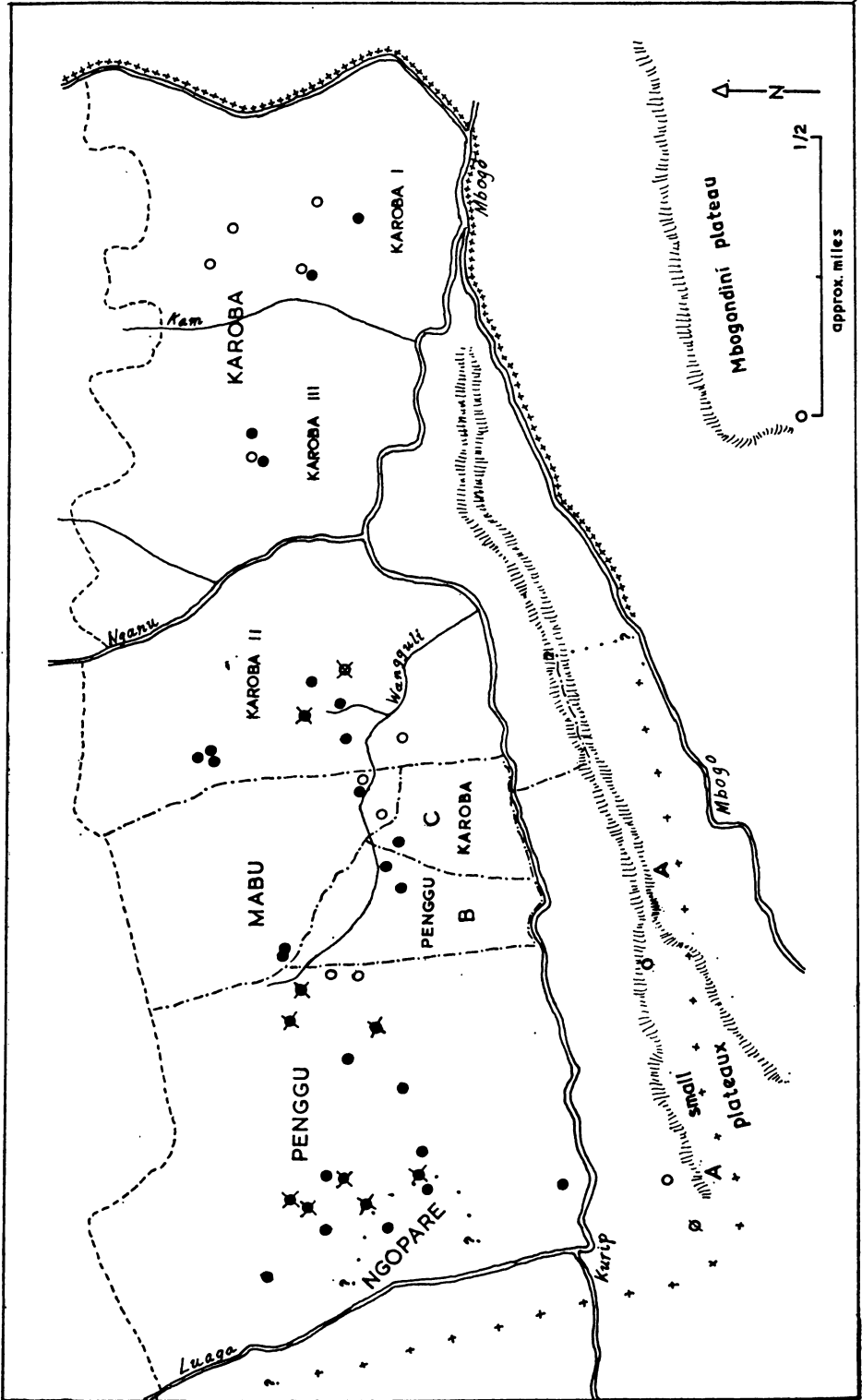

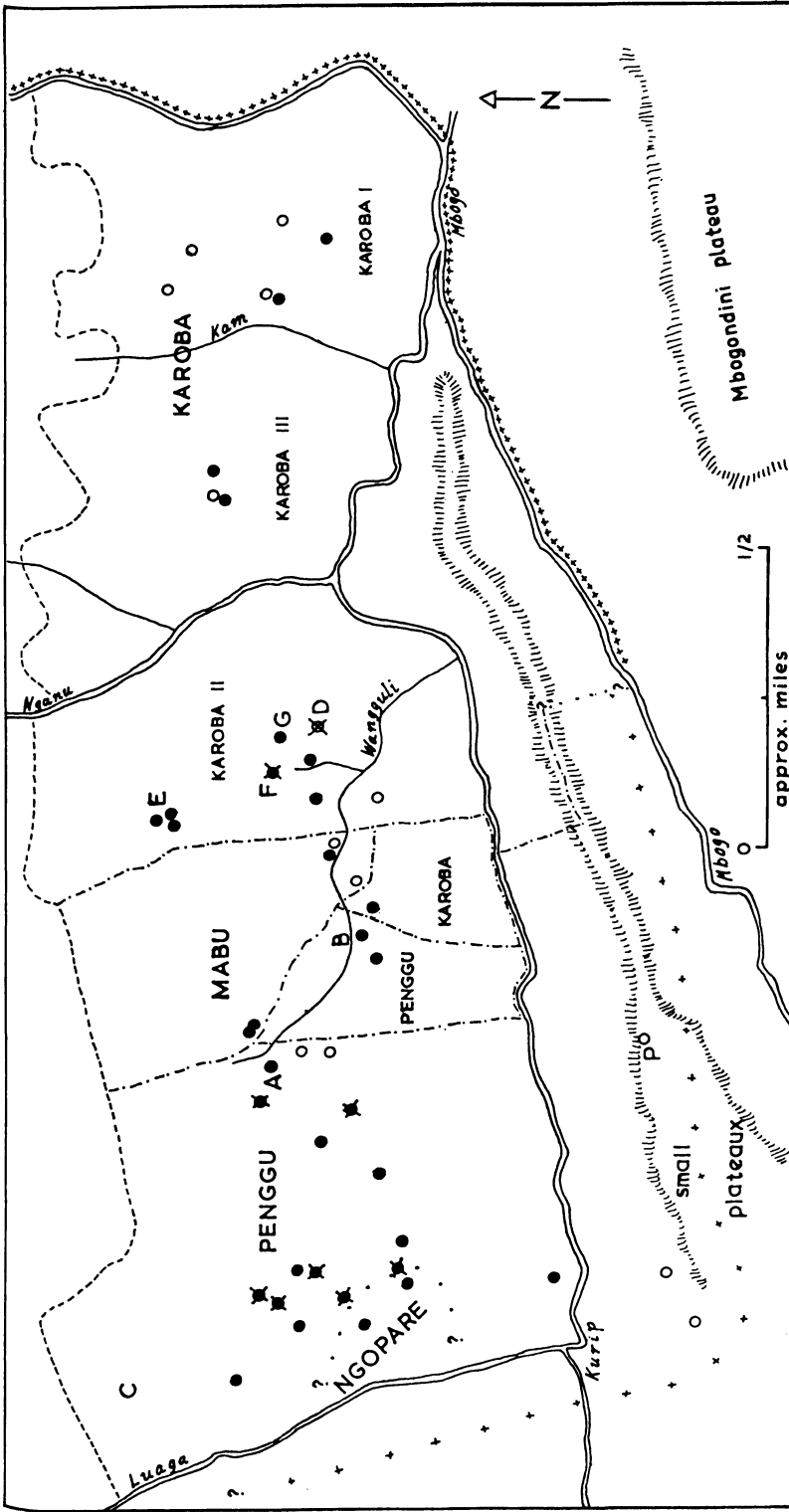

KEY TO MAP III AND MAP V

- hamlet in existence during the whole course of the fieldwork
- hamlet built during the fieldwork and still in existence at its end
- ⊗ hamlet built during the fieldwork and left before its end
- ⊗ hamlet in existence at the beginning of the fieldwork and left during its course
- ~~~~~ river
- ~~~~~ boundary jungle - gardenland
- +++++ parish boundary
- ~~~~~ creek
- ||||| ridge
- - - - - section boundary

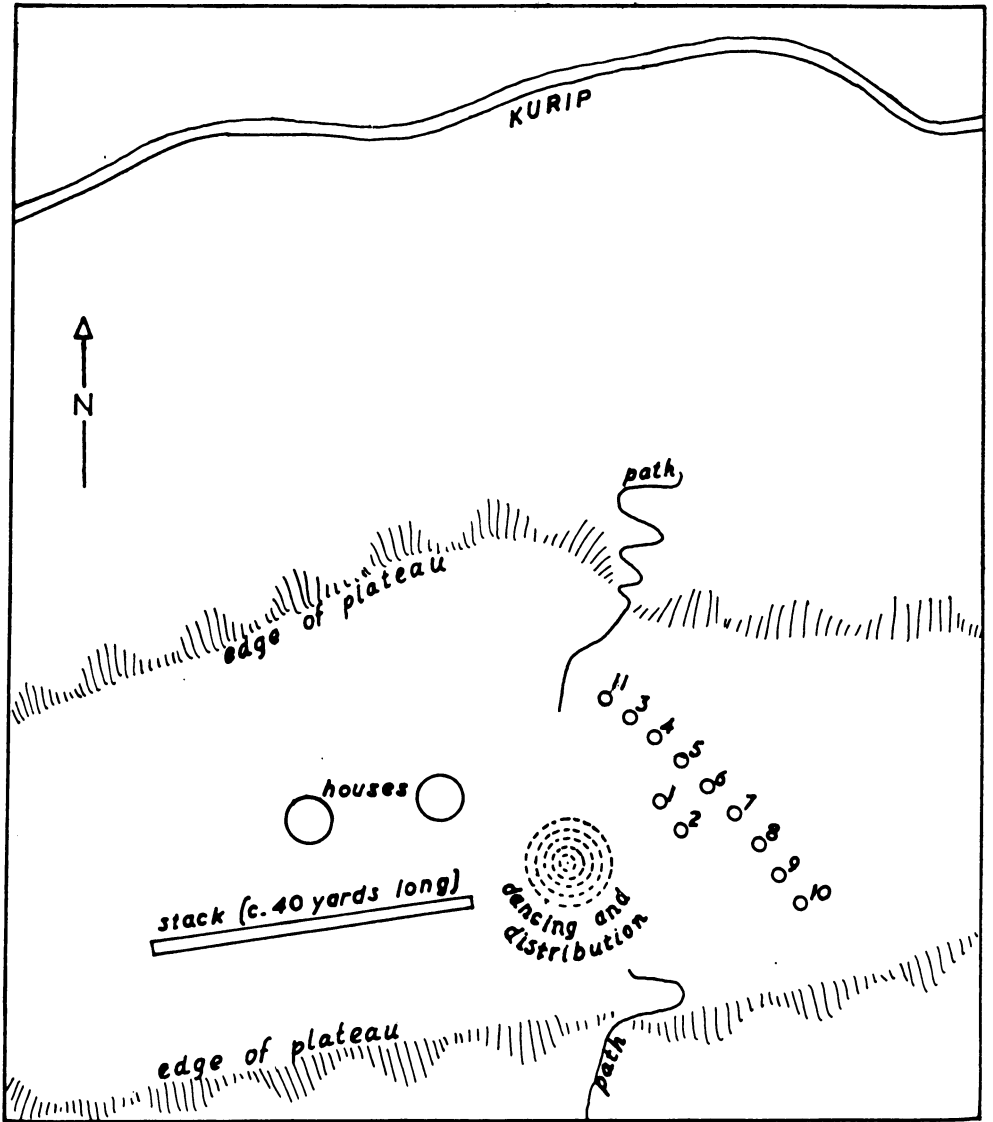

MAP VI

FEASTING GROUND FOR THE PENGGU PANDANUS FEAST

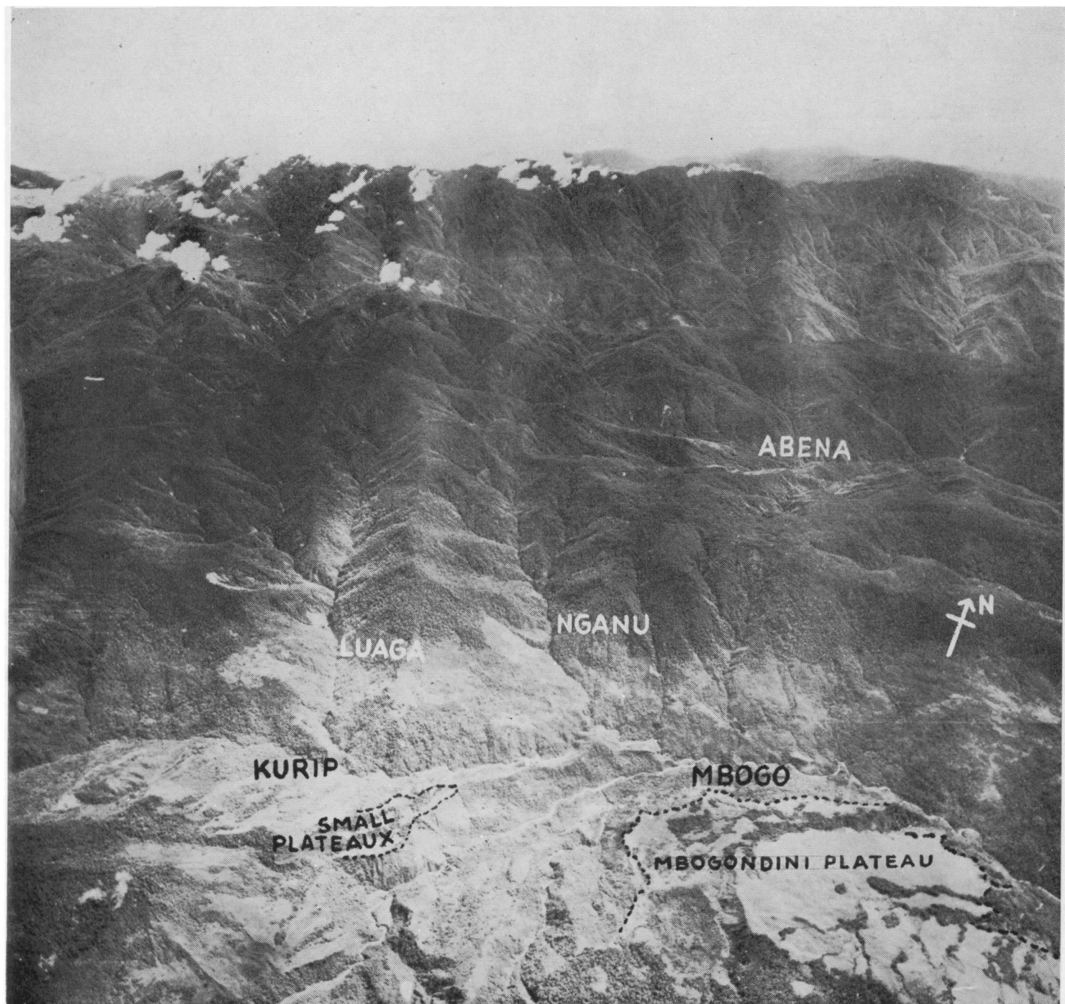

MAP IV

AERIAL PHOTOGRAPH OF WANGGULAM AND SURROUNDINGS

To facilitate comparison the names of the most important landmarks on the photograph are similarly situated to those on map III.